

BRACKET [1]

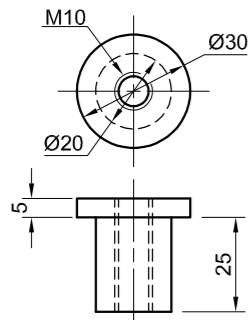

BUSH [2]

2 HOLES M10 ON 86 PCD

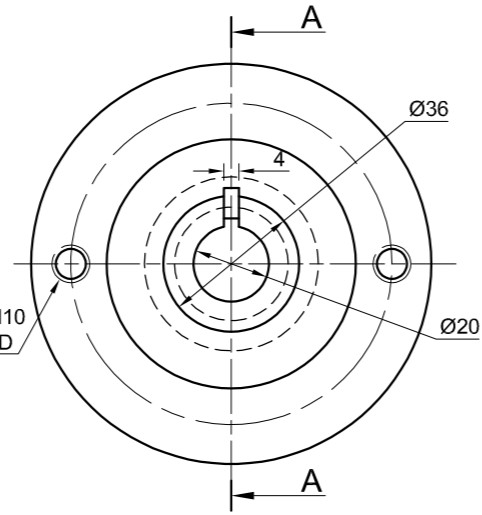

FLANGE [6]

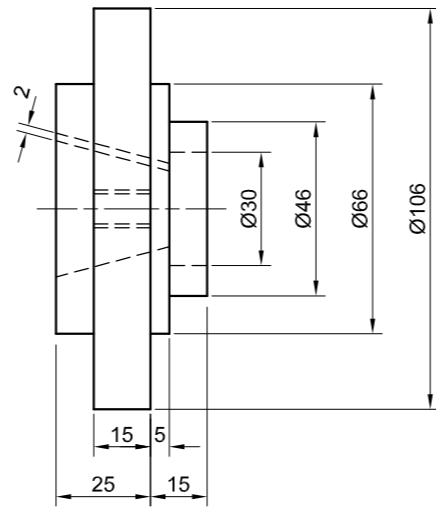

SEAL [7]

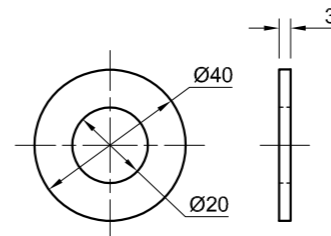

WASHER [8]

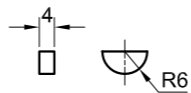

WOODRUFF KEY [5]

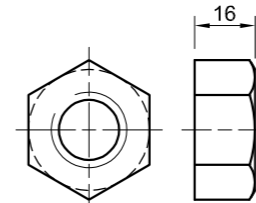

M20 NUT [9]

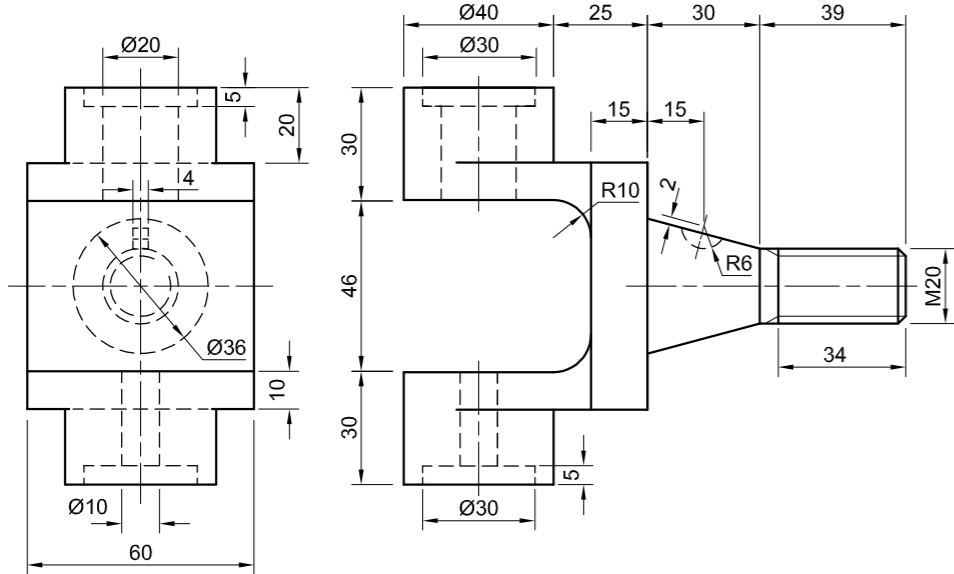

COUPLING [3]

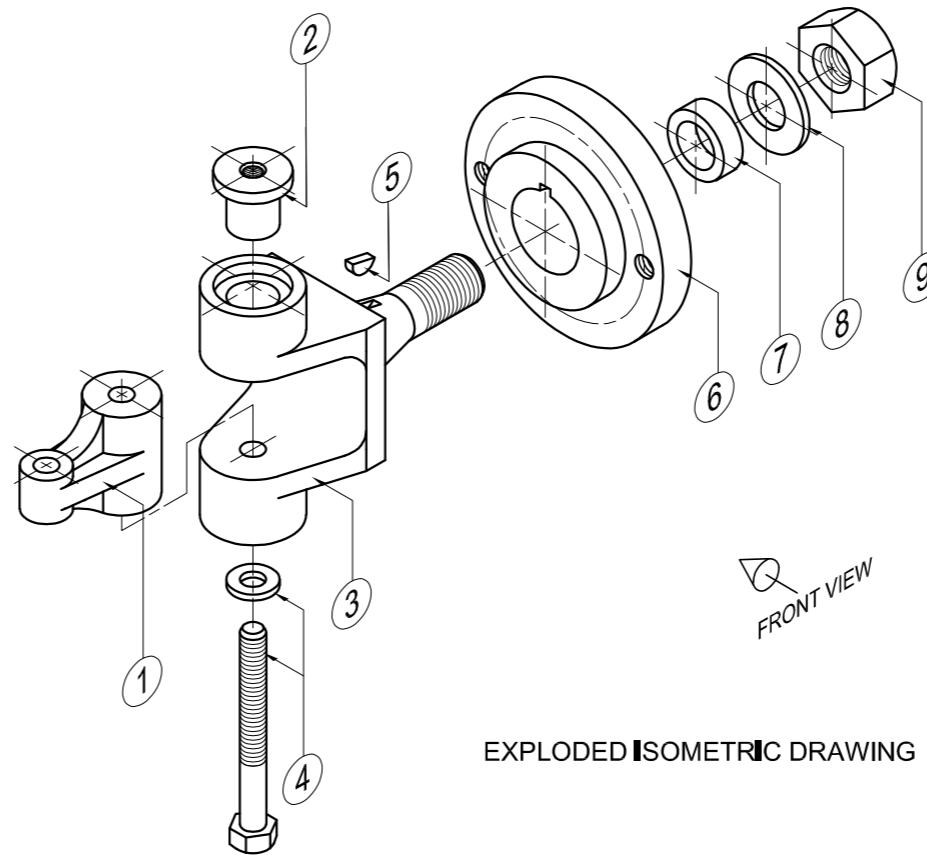

EXPLODED ISOMETRIC DRAWING

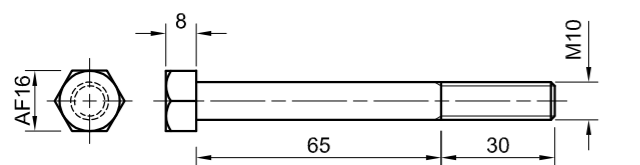

M10 BOLT + WASHER [4]

QUESTION 4: MECHANICAL ASSEMBLY

Given:

- The exploded isometric drawing of the parts of a coupling assembly, showing the position of each part relative to the others
- Orthographic views of each part of the coupling assembly

Instructions:

- Answer this question on page 6.
- Draw, to scale 1 : 1 and in third-angle orthographic projection, the following views of the assembled parts of the coupling assembly:
 - 4.1 A sectional front view on cutting plane A-A as seen from the direction of the arrow on the exploded isometric drawing. The cutting plane is shown on the left view of the flange (part 6).
 - 4.2 The left view

NOTE:

- Planning is essential.
- The drawing must comply with the SANS 10111 guidelines.
- The convention of symmetry may NOT be applied.
- Show THREE faces of the M20 NUT (part 9) on the sectional front view.
- Show TWO faces of the M10 BOLT (part 4) on the sectional front view.
- NO hidden detail is required.

[92]

PARTS LIST

PART	QUANTITY	MATERIAL
1 BRACKET	1	MILD STEEL
2 BUSH	1	BRONZE
3 COUPLING	1	MILD STEEL
4 M10 HEXAGONAL BOLT + WASHER	1	STEEL
5 WOODRUFF KEY	1	MILD STEEL
6 FLANGE	1	MILD STEEL
7 SEAL	1	RUBBER
8 WASHER	1	STEEL
9 M20 HEXAGONAL NUT	1	STEEL

BOUNTY
ENGINEERING CC

25 JUSTICE STREET
GLENVIEW
www.bounty.co.za
031 345 7869

COUPLING ASSEMBLY

ALL DIMENSIONS ARE IN MILLIMETRES.

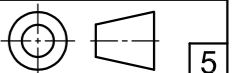

5



FOR OFFICIAL USE ONLY	
INCORRECT ORTHOGRAPHIC PROJECTION	
INCORRECT OVERALL SCALE	
INCORRECT HATCHING	
PARTS NOT ASSEMBLED	
TOTAL PENALTIES (-)	

ASSESSMENT CRITERIA					
LEFT VIEW					
		POSSIBLE	OBTAINED	SIGN	MODERATED
1	BRACKET	5			
2	COUPLING	6			
3	FLANGE	5 $\frac{1}{2}$			
4	M10 HEX. BOLT	3 $\frac{1}{2}$			
SUBTOTAL		20			
SECTIONAL FRONT VIEW					
1	BRACKET	10 $\frac{1}{2}$			
2	BUSH	5			
3	COUPLING	18 $\frac{1}{2}$			
4	M10 HEX. BOLT	8			
5	WOODRUFF KEY	2 $\frac{1}{2}$			
6	FLANGE	8			
7	SEAL	2			
8	WASHER + M20 NUT	5 $\frac{1}{2}$			
SUBTOTAL		60			
GENERAL					
1	CENTRE LINES	3			
2	ASSEMBLY	9			
SUBTOTAL		12			
TOTAL		92			
PENALTIES (-)					
GRAND TOTAL					
EXAMINATION NUMBER					
EXAMINATION NUMBER					
6					

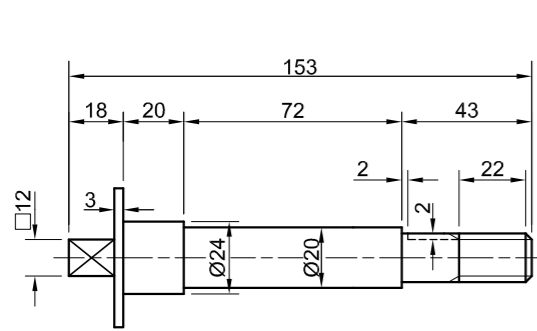

SHAFT [1]

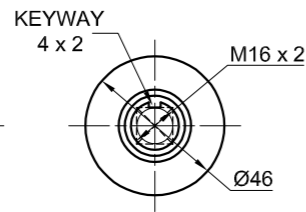

KEY [2]

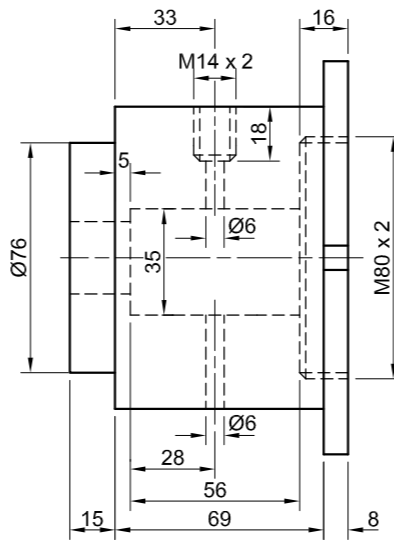

HOUSING [3]

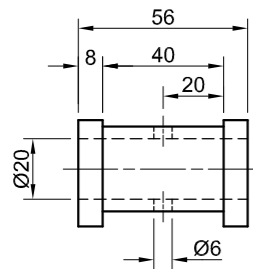
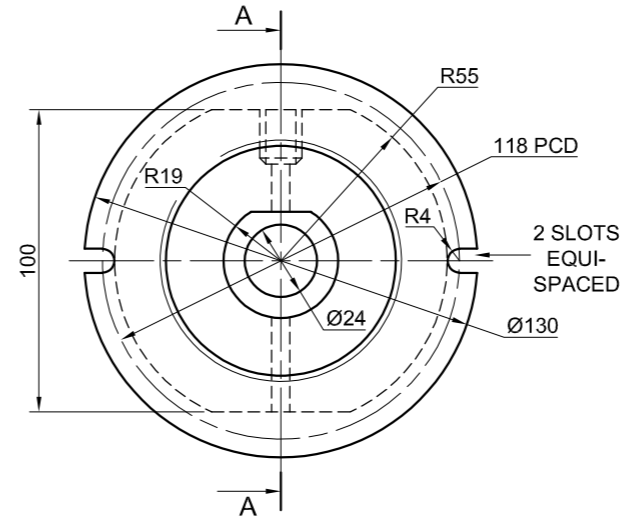

BUSH [4]

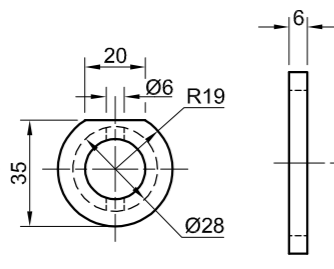

RUBBER SEAL [5]

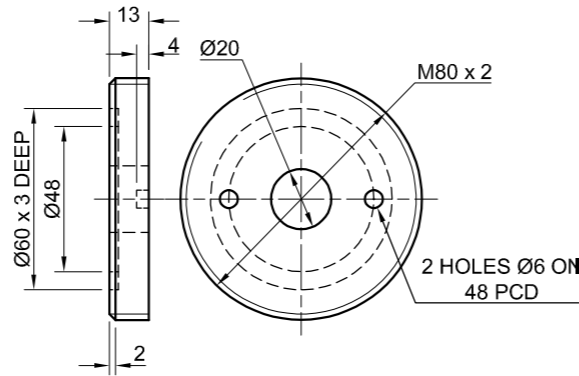

BACK PLATE [6]

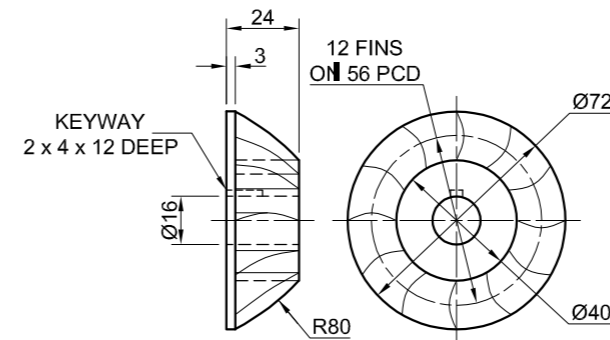

COMPRESSOR WHEEL [7]

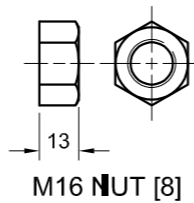

M16 NUT [8]

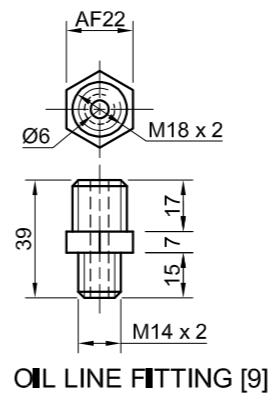

OIL LINE FITTING [9]

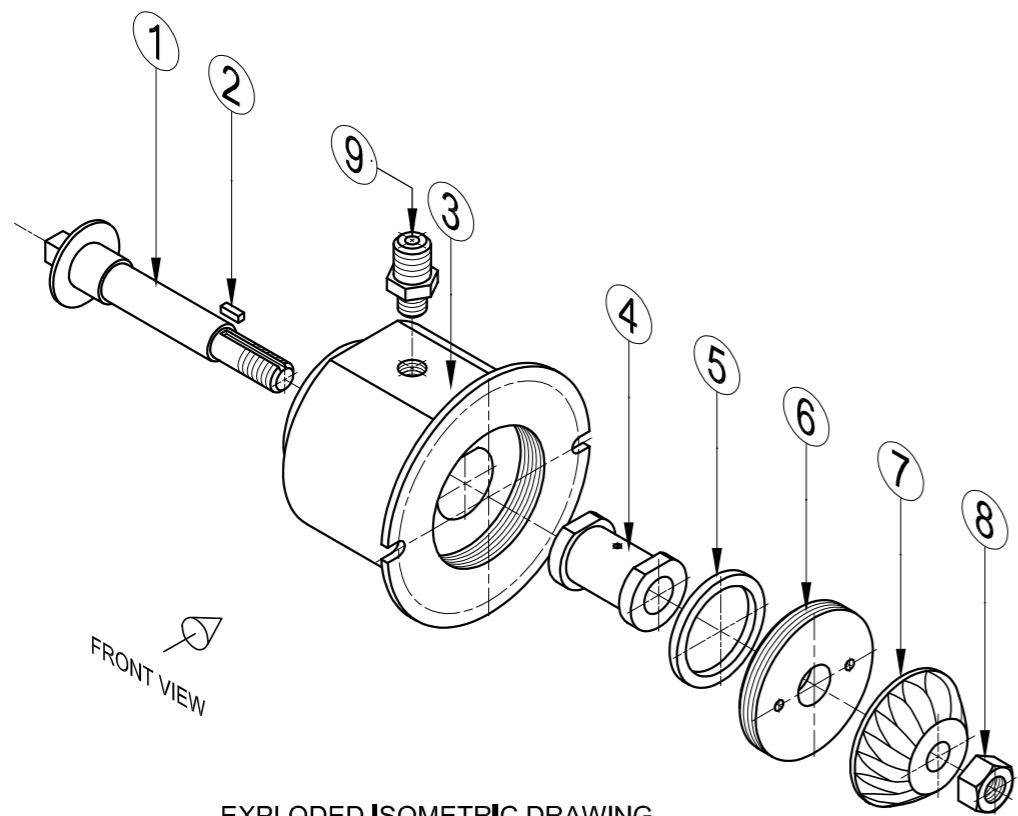

EXPLODED ISOMETRIC DRAWING

A CONVENTIONAL REPRESENTATION OF THE COMPRESSOR WHEEL

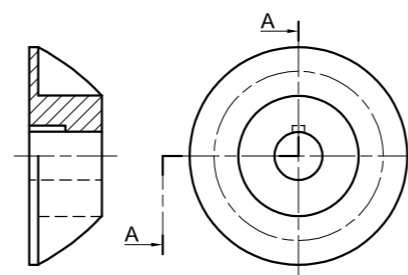

QUESTION 4: MECHANICAL ASSEMBLY

Given:

- The exploded isometric drawing of the parts of a turbo core assembly, showing the position of each part relative to all the others
- Orthographic views of each of the parts of the turbo core assembly
- A conventional representation of the compressor wheel (part 7)

Instructions:

- Answer this question on page 6.
- Draw, to scale 1 : 1 and in third-angle orthographic projection, the following views of the assembled parts of the turbo core assembly:
 - 4.1 A sectional front view on cutting plane A-A, as seen from the direction of the arrow on the exploded isometric drawing. The cutting plane is shown on the right view of the housing (part 3).
 - 4.2 The right view

NOTE:

- Planning is essential.
- ALL drawings must comply with the SANS 10111 guidelines.
- The convention of symmetry may NOT be applied.
- Show THREE faces of the M16 nut (part 8) in the front view.
- Draw the compressor wheel (part 7) as a conventional representation.
- NO hidden detail is required.

[93]

PARTS LIST

PART	QUANTITY	MATERIAL
1 SHAFT	1	STAINLESS STEEL
2 KEY	1	MILD STEEL
3 HOUSING	1	CAST IRON
4 BUSH	1	BRASS
5 RUBBER SEAL	1	RUBBER
6 BACK PLATE	1	ALUMINIUM
7 COMPRESSOR WHEEL	1	ALUMINIUM ALLOY
8 M16 NUT	1	MILD STEEL
9 OIL LINE FITTING	1	MILD STEEL

JVBW
ENGINEERING CC

7 POWER AVE
CORON PARK
www.speedy.co.za
091 345 6147

TURBO CORE

ALL DIMENSIONS ARE IN MILLIMETRES.

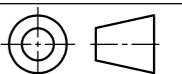

5



FOR OFFICIAL USE ONLY	
INCORRECT ORTHOGRAPHIC PROJECTION	
INCORRECT OVERALL SCALE	
INCORRECT HATCHING	
PARTS NOT ASSEMBLED	
TOTAL PENALTIES (-)	

ASSESSMENT CRITERIA				
RIGHT VIEW				
		POSSIBLE	OBTAINED	SIGN MODERATED
1	HOUSING + SHAFT	6 1/2		
2	BACK PLATE + COMPRESSOR WHEEL	3		
3	M16 NUT	2 1/2		
4	OIL LINE FITTING	2 1/2		
SUBTOTAL		14 1/2		
SECTIONAL FRONT VIEW				
1	SHAFT	12 1/2		
2	KEY	2		
3	HOUSING	18		
4	BUSH	5 1/2		
5	RUBBER SEAL	4		
6	BACK PLATE	3 1/2		
7	COMPRESSOR WHEEL	8		
8	M16 NUT	4		
9	OIL LINE FITTING	10		
SUBTOTAL		67 1/2		
GENERAL				
1	CENTRE LINES	3		
2	ASSEMBLY	8		
SUBTOTAL		11		
TOTAL		93		
PENALTIES (-)				
GRAND TOTAL				
EXAMINATION NUMBER				
EXAMINATION NUMBER				
6				

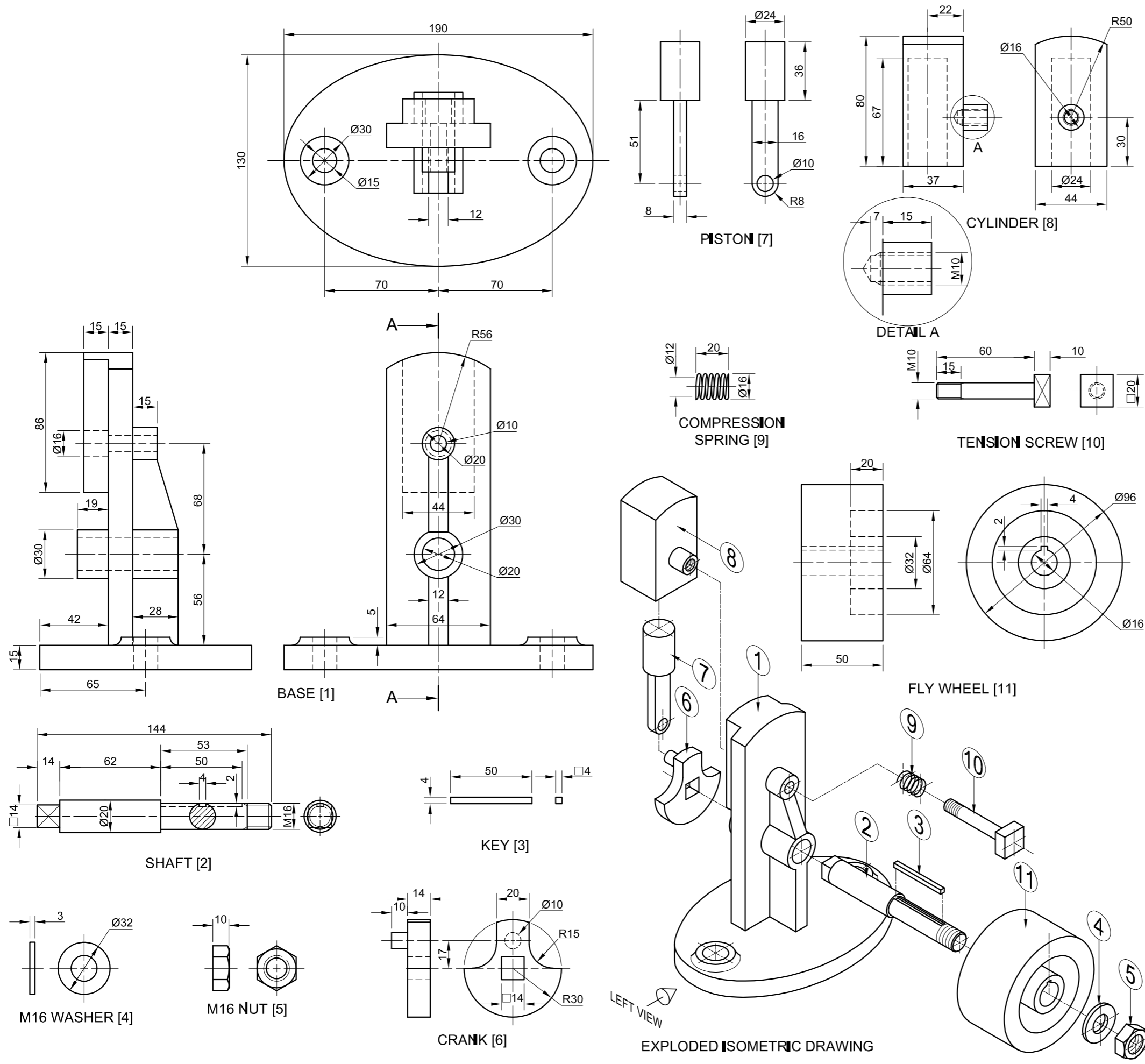

QUESTION 4: MECHANICAL ASSEMBLY

Given:

- The exploded isometric drawing of the parts of a wobble engine assembly, showing the position of each part relative to all the others
- Orthographic views of each of the parts of the wobble engine assembly

Instructions:

- Answer this question on page 6.
- Draw, to scale 1 : 1 and in third-angle orthographic projection, the following views of the assembled parts of the wobble engine assembly:
 - 4.1 ONLY the left half of the front view, by applying the convention of symmetry.
 - 4.2 A sectional left view on cutting plane A-A, as seen from the direction of the arrow on the exploded isometric drawing. The cutting plane is shown on the front view of the base (part 1).

NOTE:

- Planning is essential.
- The drawing must comply with the SANS 10111 guidelines.
- The piston (part 7) must be drawn in the highest position.
- Show THREE faces of the M16 nut (part 5) on the sectional view.
- The compression spring (part 9) must be drawn as a conventional representation, at the full extension of 20 mm.
- NO hidden detail is required. [93]

PARTS LIST

	PARTS	QUANTITY	MATERIAL
1	BASE	1	CAST IRON
2	SHAFT	1	MILD STEEL
3	KEY	1	KEY STEEL
4	M16 WASHER	1	MILD STEEL
5	M16 NUT	1	MILD STEEL
6	CRANK	1	CAST IRON
7	PISTON	1	MILD STEEL
8	CYLINDER	1	CAST IRON
9	COMPRESSION SPRING	1	SPRING STEEL
10	TENSION SCREW	1	MILD STEEL
11	FLY WHEEL	1	CAST IRON

STEAM PUNK
ENGINEERING CC

7 WATT STREET
INDUSTRIA
www.steamp.co.za
012 345 6789

WOBBLE ENGINE ASSEMBLY

ALL DIMENSIONS ARE IN MILLIMETRES.

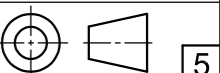



FOR OFFICIAL USE ONLY	
INCORRECT ORTHOGRAPHIC PROJECTION	
INCORRECT OVERALL SCALE	
INCORRECT HATCHING	
PARTS NOT ASSEMBLED	
TOTAL PENALTIES (-)	

ASSESSMENT CRITERIA				
FRONT VIEW				
		POSSIBLE	OBTAINED	SIGN MODERATED
1	BASE	5 1/2		
2	TENSION SCREW	1 1/2		
3	FLY WHEEL	1		
4	NUT + WASHER	4 1/2		
5	INDICATION OF SYMMETRY	2		
SUBTOTAL		14 1/2		
SECTIONAL LEFT VIEW				
1	BASE	13 1/2		
2	CYLINDER	10		
3	PISTON	5 1/2		
4	TENSION SCREW	8		
5	SPRING	1 1/2		
6	CRANK	5 1/2		
7	SHAFT + KEY + WASHER + NUT	15 1/2		
8	FLY WHEEL	7		
SUBTOTAL		66 1/2		
GENERAL				
1	CENTRE LINES	2		
2	ASSEMBLY	10		
SUBTOTAL		12		
TOTAL		93		
PENALTIES (-)				
GRAND TOTAL				
EXAMINATION NUMBER				
EXAMINATION NUMBER				
6				

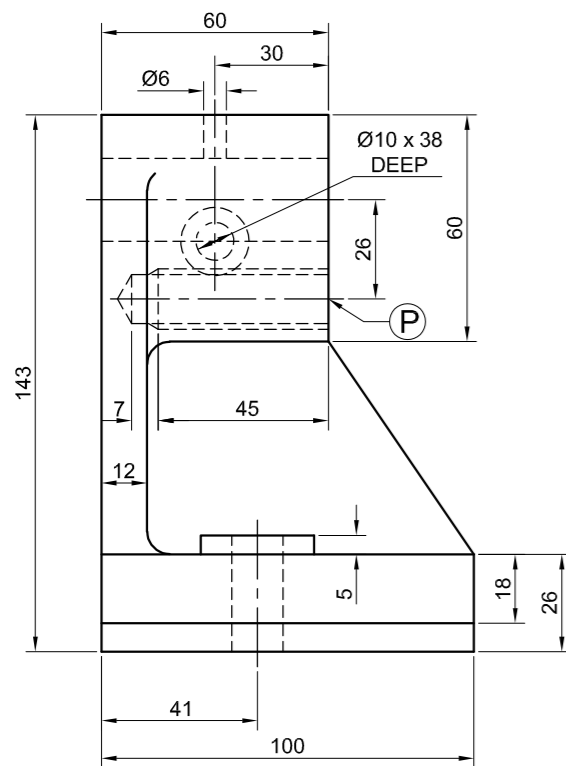

TAILSTOCK [1]

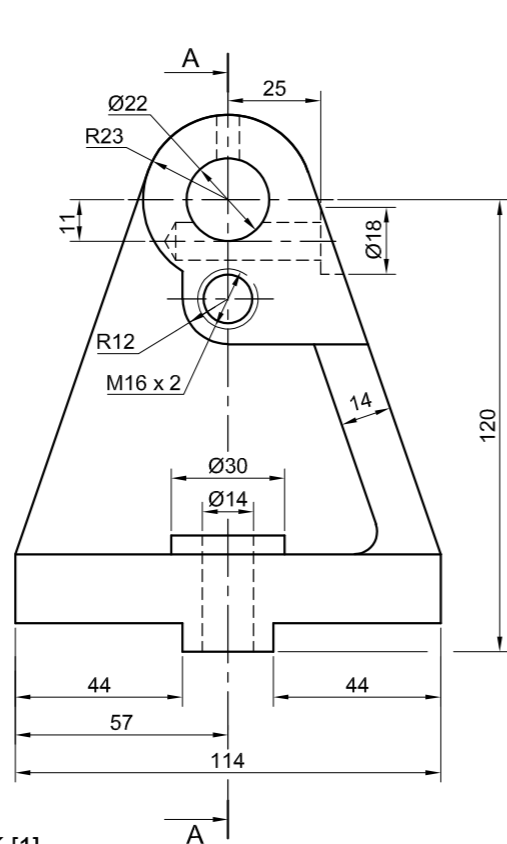

ADJUSTING HAND WHEEL [4]

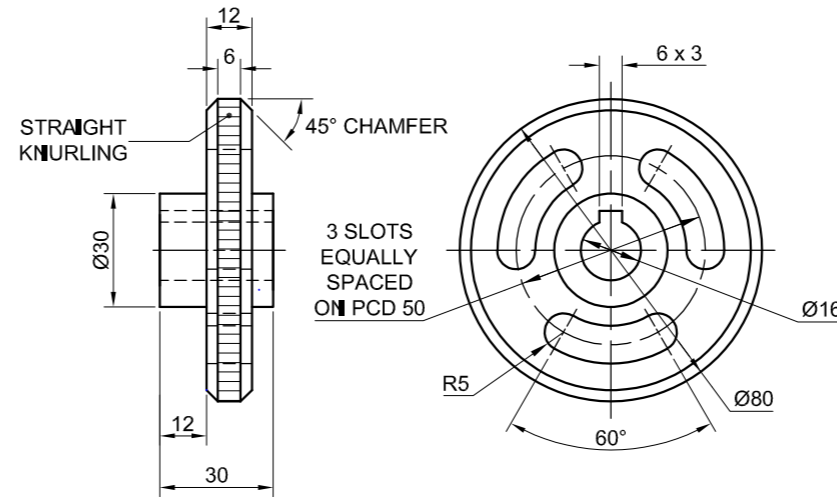

KEY [5]

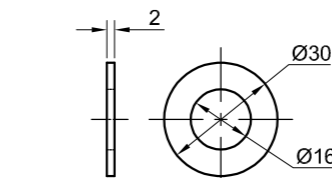

WASHER [6]

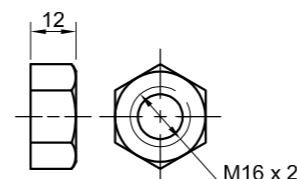

M16 NUT [7]

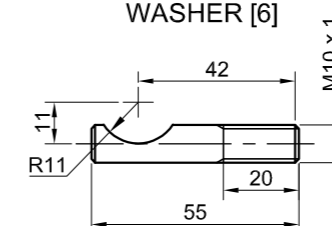

M10 LOCKING STUD [8]

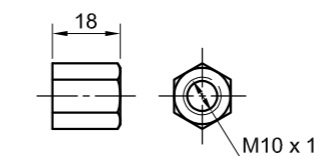

M10 LOCKING NUT [9]

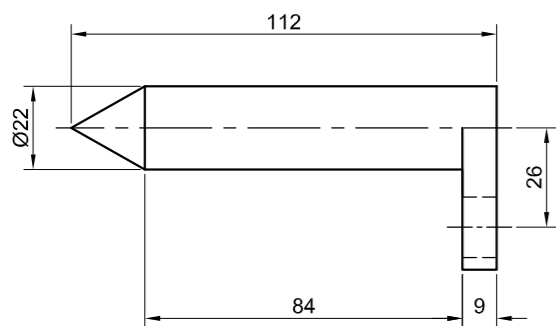

DEAD CENTRE [2]

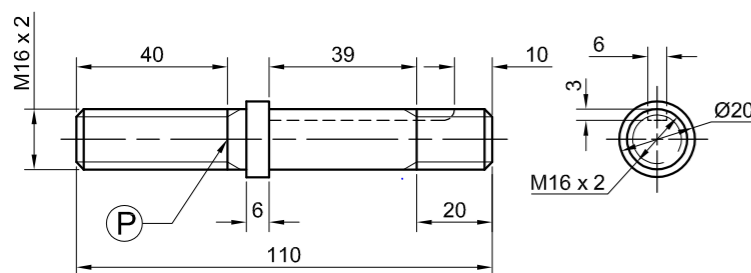

ADJUSTING STUD [3]

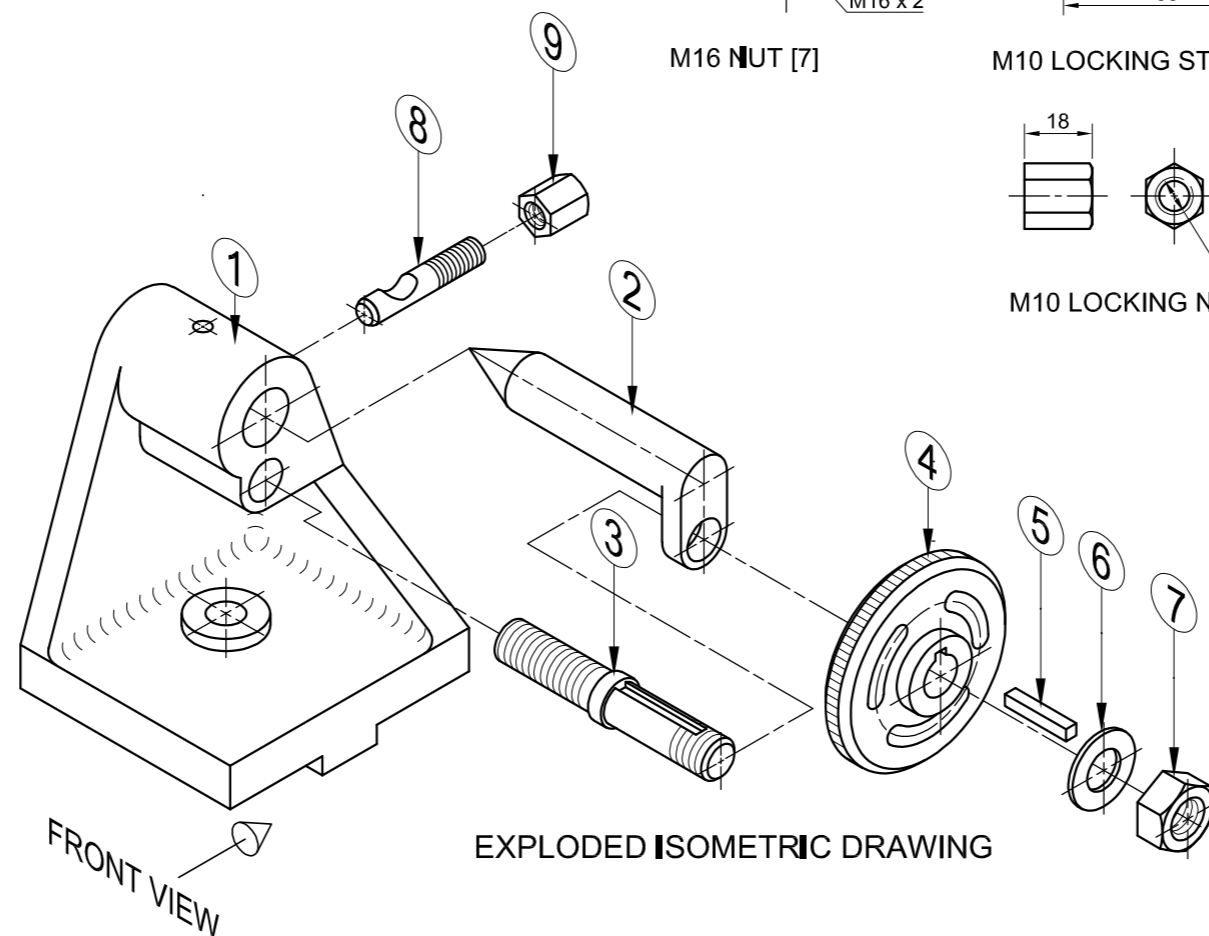

EXPLODED ISOMETRIC DRAWING

QUESTION 4: MECHANICAL ASSEMBLY

Given:

- The exploded isometric drawing of the parts of a tailstock assembly, showing the position of each part relative to all the others
- Orthographic views of each of the parts of the tailstock assembly

Instructions:

- Answer this question on page 6.
- Draw, to scale 1 : 1 and in third-angle orthographic projection, the following views of the assembled parts of the tailstock assembly:
 - 4.1 A sectional front view on cutting plane A-A, as seen from the direction of the arrow on the exploded isometric drawing. The cutting plane is shown on the right view of the tailstock (part 1).
 - 4.2 The right view

NOTE:

- Planning is essential.
- The drawing must comply with the SANS 10111 guidelines.
- Align point P on the adjusting stud (part 3) with point P on the tailstock (part 1).
- Show THREE faces of the M16 nut (part 7) in the front view and TWO faces of the M10 locking nut (part 9) in the right view.
- NO hidden detail is required.
- Add cutting plane A-A.

[93]

PARTS LIST

PARTS	QUANTITY	MATERIAL
1 TAILSTOCK	1	CAST IRON
2 DEAD CENTRE	1	ALLOY STEEL
3 ADJUSTING STUD	1	MILD STEEL
4 ADJUSTING HAND WHEEL	1	CAST STEEL
5 KEY	1	MILD STEEL
6 WASHER	1	MILD STEEL
7 M16 NUT	1	MILD STEEL
8 M10 LOCKING STUD	1	MILD STEEL
9 M10 LOCKING NUT	1	MILD STEEL

TURNIT
ENGINEERING CC

11 SALAH ROAD
MANIE
www.turnit.co.za

TAILSTOCK ASSEMBLY

ALL DIMENSIONS ARE IN MILLIMETRES.
ALL UNSPECIFIED RADII ARE 6 mm.

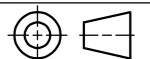

5



FOR OFFICIAL USE ONLY	
INCORRECT ORTHOGRAPHIC PROJECTION	
INCORRECT OVERALL SCALE	
INCORRECT HATCHING	
PARTS NOT ASSEMBLED	
TOTAL PENALTIES (-)	

ASSESSMENT CRITERIA					
RIGHT VIEW					
		POSSIBLE	OBTAINED	SCORE	MODERATED
1	TAILSTOCK	8 1/2			
2	ADJUSTING WHEEL + DEAD CENTRE	8			
3	M16 NUT + WASHER + LOCKING NUT	6 1/2			
4	ADJUSTING STUD	1 1/2			
SUBTOTAL		24 1/2			
SECTIONAL FRONT VIEW					
1	TAILSTOCK	14			
2	DEAD CENTRE	7			
3	ADJUSTING WHEEL	9			
4	ADJUSTING STUD	16 1/2			
5	M16 NUT + WASHER + M10 LOCKING BOLT	6 1/2			
6	KEY	1 1/2			
SUBTOTAL		54 1/2			
GENERAL					
1	CENTRE LINES	4			
2	CUTTING PLANE	3			
3	ASSEMBLY	7			
SUBTOTAL		14			
TOTAL		93			
PENALTIES (-)					
GRAND TOTAL					
EXAMINATION NUMBER					
					6

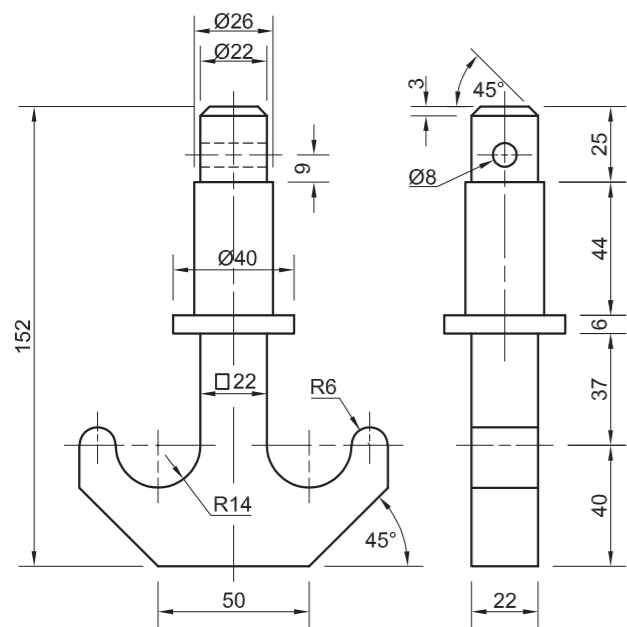

CRANE HOOK [1]

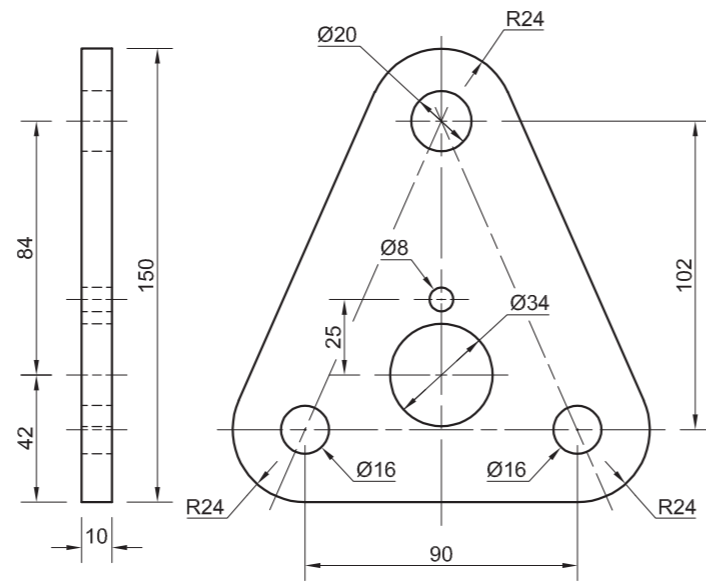

SUPPORT PLATE [2]

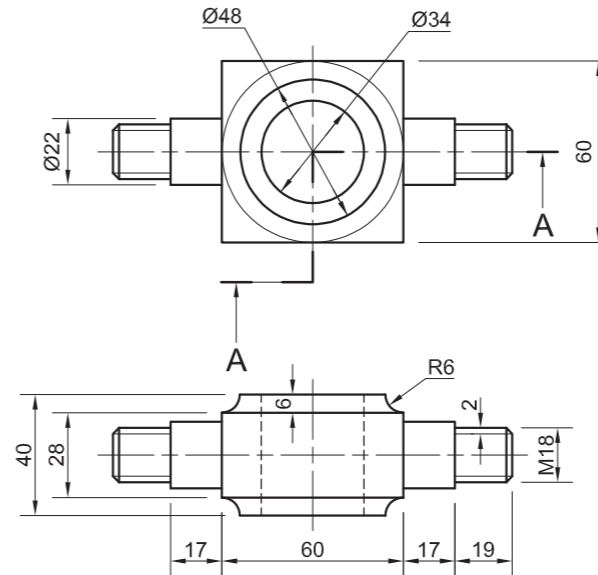

HOOK ANCHOR [3]

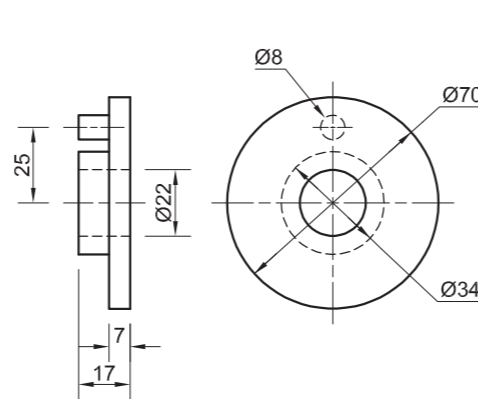

END BUSH [4]

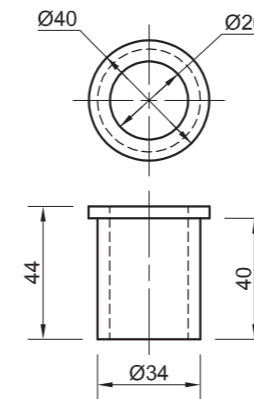

BUSH [5]

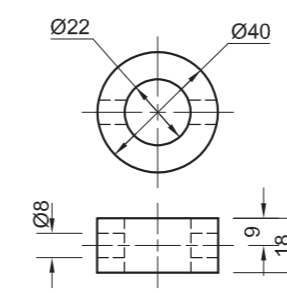

COLLAR [6]

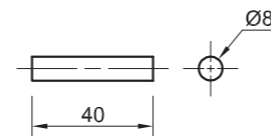

PIN [7]

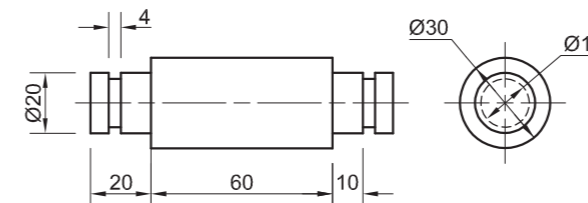

UPPER SPACER [8]

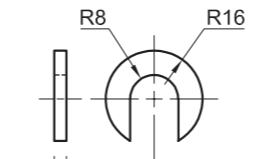

RETENTION CLIP [9]

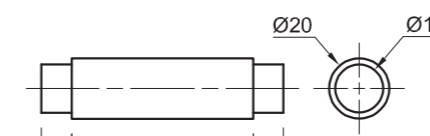

LOWER SPACER [10]

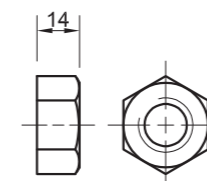

M18 NUT [11]

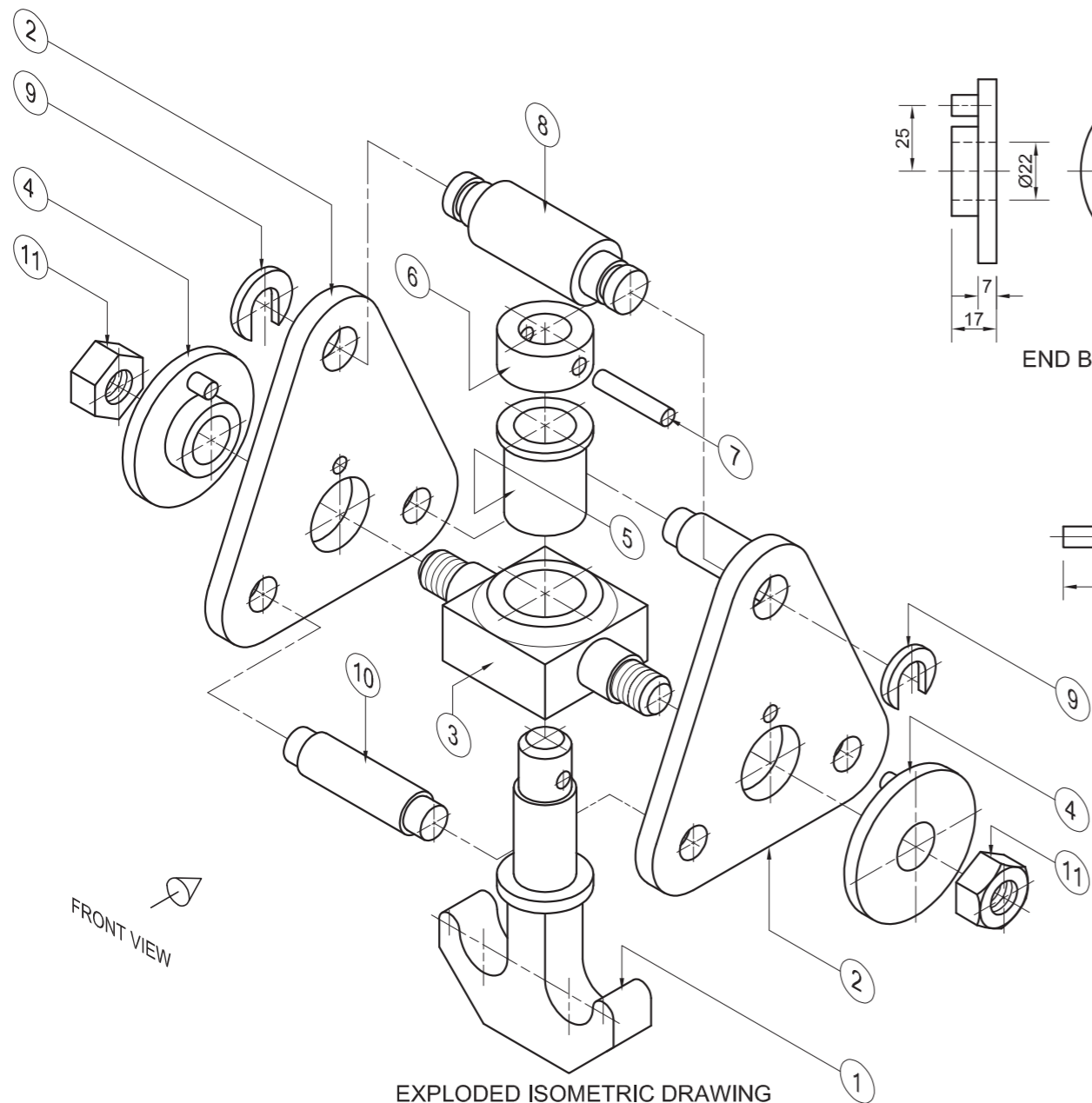

EXPLODED ISOMETRIC DRAWING

QUESTION 4: MECHANICAL ASSEMBLY

Given:

- The exploded isometric drawing of the parts of a crane hook assembly, showing the position of each part relative to all the others
- Orthographic views of each of the parts of the crane hook assembly

Instructions:

- Answer this question on page 6.
- Draw, to scale 1 : 1 and in third-angle orthographic projection, the following views of the assembled parts of the crane hook assembly:

4.1 The right view.

4.2 A half sectional front view on cutting plane A-A.

Show the right half in section, as seen from the direction of the arrow as shown on the exploded isometric drawing. The cutting plane is shown on the top view of the hook anchor (part 3).

NOTE:

- Planning is essential.
- The drawing must comply with the SANS 10111 guidelines.
- The convention of symmetry may NOT be applied.
- Show THREE faces of the M18 nut (part 11) on the right side and TWO faces of the M18 nut (part 11) on the left side of the half sectional view.
- NO hidden detail is required.

[92]

PARTS LIST

PARTS	QUANTITY	MATERIAL
1 CRANE HOOK	1	FORGED STEEL
2 SUPPORT PLATE	2	MILD STEEL
3 HOOK ANCHOR	1	MILD STEEL
4 END BUSH	2	MILD STEEL
5 BUSH	1	MILD STEEL
6 COLLAR	1	MILD STEEL
7 PIN	1	MILD STEEL
8 UPPER SPACER	1	MILD STEEL
9 RETENTION CLIP	2	MILD STEEL
10 LOWER SPACER	2	MILD STEEL
11 M18 NUT	2	MILD STEEL

LIFTWELL
ENGINEERING CC

7 MAC STREET
INDUSTRIA
www.liftwell.co.za
012 345 6789

CRANE HOOK ASSEMBLY

ALL DIMENSIONS ARE IN MILLIMETRES.

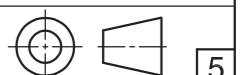

5





FOR OFFICIAL USE ONLY	
INCORRECT ORTHOGRAPHIC PROJECTION	
INCORRECT OVERALL SCALE	
INCORRECT HATCHING	
PARTS NOT ASSEMBLED	
TOTAL PENALTIES (-)	

ASSESSMENT CRITERIA					
RIGHT VIEW					
		POSSIBLE	OBTAINED	SIGN	MODERATED
1	CRANE HOOK	2 ½			
2	SUPPORT PLATES + LOWER SPACERS	4			
3	HOOK ANCHOR + END BUSH	2			
4	RETENTION CLIP + UPPER SPACER	2			
5	M18 NUT	2 ½			
SUBTOTAL		13			
HALF SECTIONAL FRONT VIEW					
1	CRANE HOOK	13			
2	SUPPORT PLATES	7			
3	HOOK ANCHOR	11			
4	END BUSHES	7 ½			
5	UPPER + LOWER SPACERS	8			
6	BUSH	2			
7	COLLAR + PIN	4 ½			
8	RETENTION CLIPS	4			
9	M18 NUTS	7			
10	NO HATCHING LEFT HALF	1			
SUBTOTAL		65			
GENERAL					
1	CENTRE LINES	3			
2	ASSEMBLY	11			
SUBTOTAL		14			
TOTAL		92			
PENALTIES (-)					
GRAND TOTAL					
EXAMINATION NUMBER					
EXAMINATION NUMBER					
EXAMINATION NUMBER					



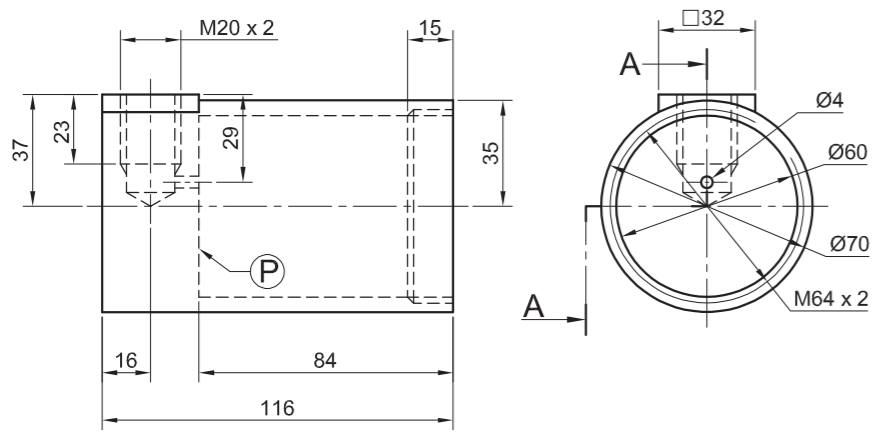

CYLINDER [1]

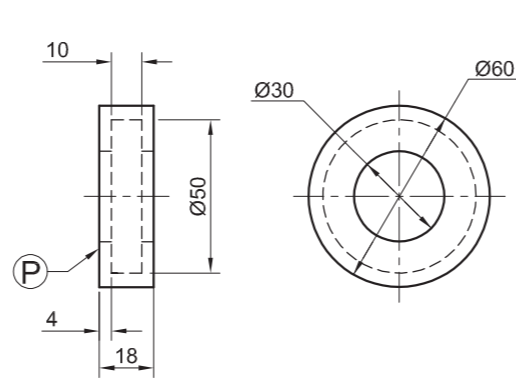

RUBBER SEAL [2]

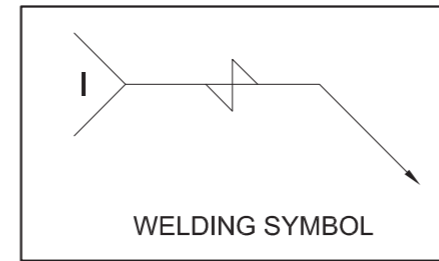

WELDING SYMBOL

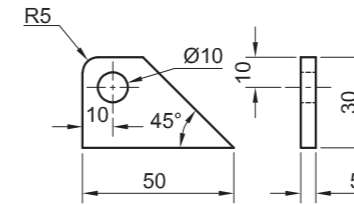

HOOK [6]

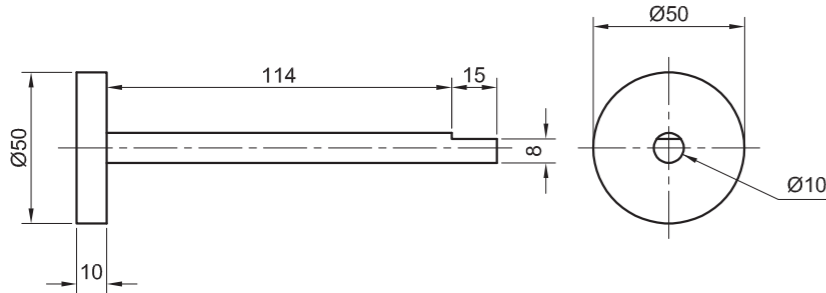

PLUNGER [3]

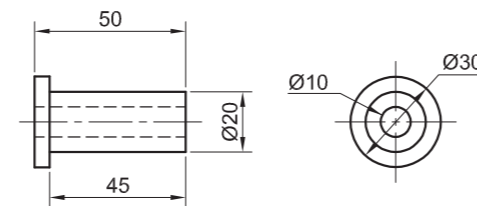

BUSH [4]

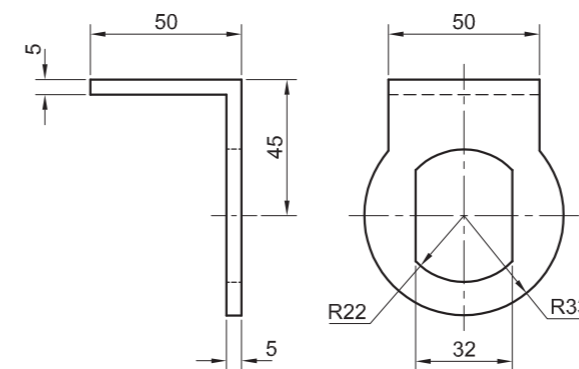

BRACKET [7]

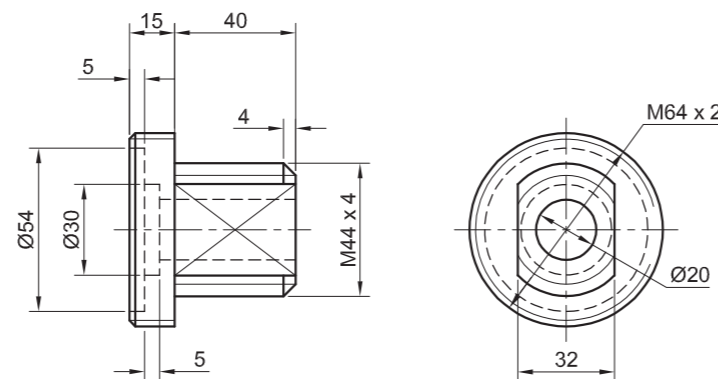

GUIDE [5]

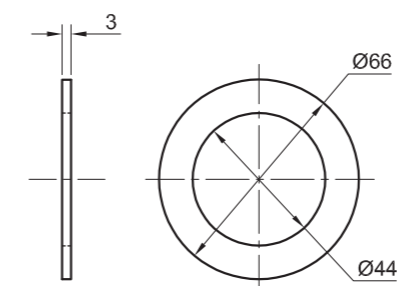

WASHER [8]

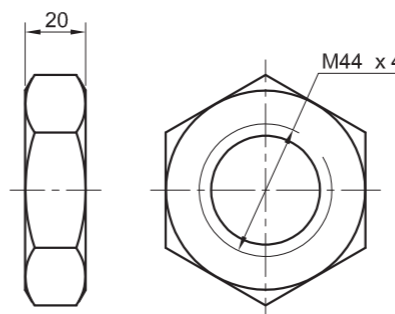

M44 NUT [9]

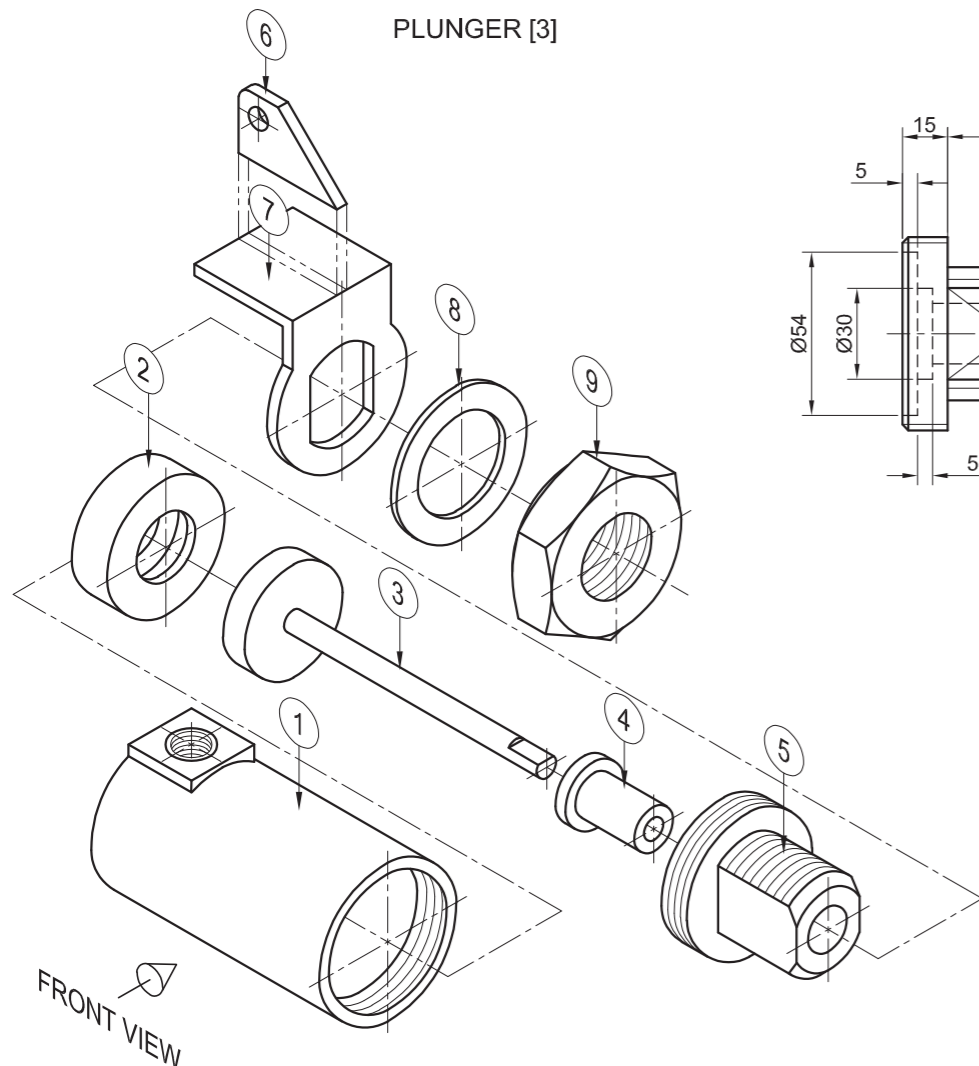

EXPLODED ISOMETRIC DRAWING

QUESTION 4: ASSEMBLY DRAWING

Given:

- The exploded isometric drawing of the parts of a pressure pump assembly, showing the position of each part relative to all the others
- Orthographic views of each of the parts of the pressure pump assembly
- A welding symbol

Instructions:

- Answer this question on page 6.
- Draw, to scale 1 : 1 and in third-angle orthographic projection, the following views of the assembled parts of the pressure pump assembly:

4.1 A half-sectional front view on cutting plane A-A, as seen from the direction of the arrow on the exploded isometric drawing. The cutting plane is shown on the right view of the cylinder (part 1).

- 4.2 The top view**
- 4.3 The right view**

NOTE:

- Planning is essential.
- The drawing must comply with the guidelines as contained in the SANS 10111.
- The convention of symmetry may NOT be applied.
- Place the head of the plunger (part 3) inside the rubber seal (part 2).
- Place surface P on the rubber seal (part 2) against surface P on the inside of the cylinder (part 1).
- Show THREE faces of the M44 nut (part 9) in the front view.
- The hook (part 6) must be welded onto the bracket (part 7). Draw, to the given size, the complete welding symbol in the correct position on the right view.
- NO hidden detail is required.

[90]

PARTS LIST

PART	QUANTITY	MATERIAL	
1	CYLINDER	1	ALUMINIUM
2	RUBBER SEAL	1	RUBBER
3	PLUNGER	1	MILD STEEL
4	BUSH	1	BRASS
5	GUIDE	1	ALUMINIUM
6	HOOK	1	MILD STEEL
7	BRACKET	1	MILD STEEL
8	WASHER	1	MILD STEEL
9	M44 NUT	1	MILD STEEL

WESTO PUMPS
ENGINEERING (PTY) LTD

102 OAK STREET
DINALEDI PARK 1020
www.westopumps.za

PRESSURE PUMP

ALL DIMENSIONS ARE IN MILLIMETRES

ALL UNSPECIFIED RADII ARE 3 mm



5





FOR OFFICIAL USE ONLY	
INCORRECT OVERALL SCALE	
INCORRECT HATCHING	
PARTS NOT ASSEMBLED	
TOTAL PENALTIES (-)	

ASSESSMENT CRITERIA					
RIGHT VIEW					
		POSSIBLE	OBTAINED	SIGN	MODERATED
1	SHAFT + BUSH	1 1/2			
2	CYLINDER + BRACKET + HOOK	4			
3	M44 NUT + GUIDE	6			
SUBTOTAL		11 1/2			
HALF-SECTIONAL FRONT VIEW					
1	CYLINDER	12			
2	RUBBER SEAL	2 1/2			
3	PLUNGER	5			
4	BUSH	2 1/2			
5	GUIDE	11 1/2			
6	BRACKET + HOOK	6			
7	M44 NUT + WASHER	6 1/2			
SUBTOTAL		46			
TOP VIEW					
1	CYLINDER	5 1/2			
2	BRACKET + HOOK	3 1/2			
3	GUIDE + SHAFT	4 1/2			
4	M44 NUT + WASHER	4			
SUBTOTAL		17 1/2			
GENERAL					
1	CENTRE LINES	3			
2	ASSEMBLY	8			
3	WELDING SYMBOL	4			
SUBTOTAL		15			
TOTAL		90			
PENALTIES (-)					
GRAND TOTAL					
EXAMINATION NUMBER					
EXAMINATION NUMBER					
					6



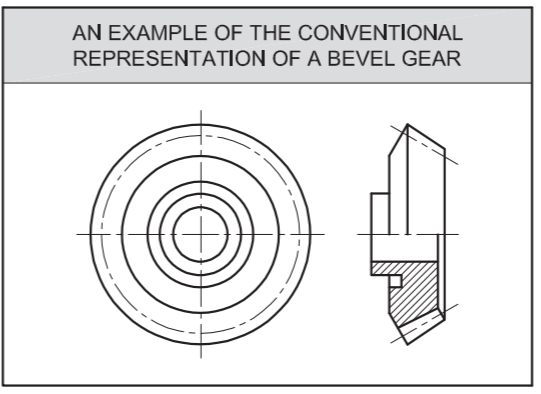
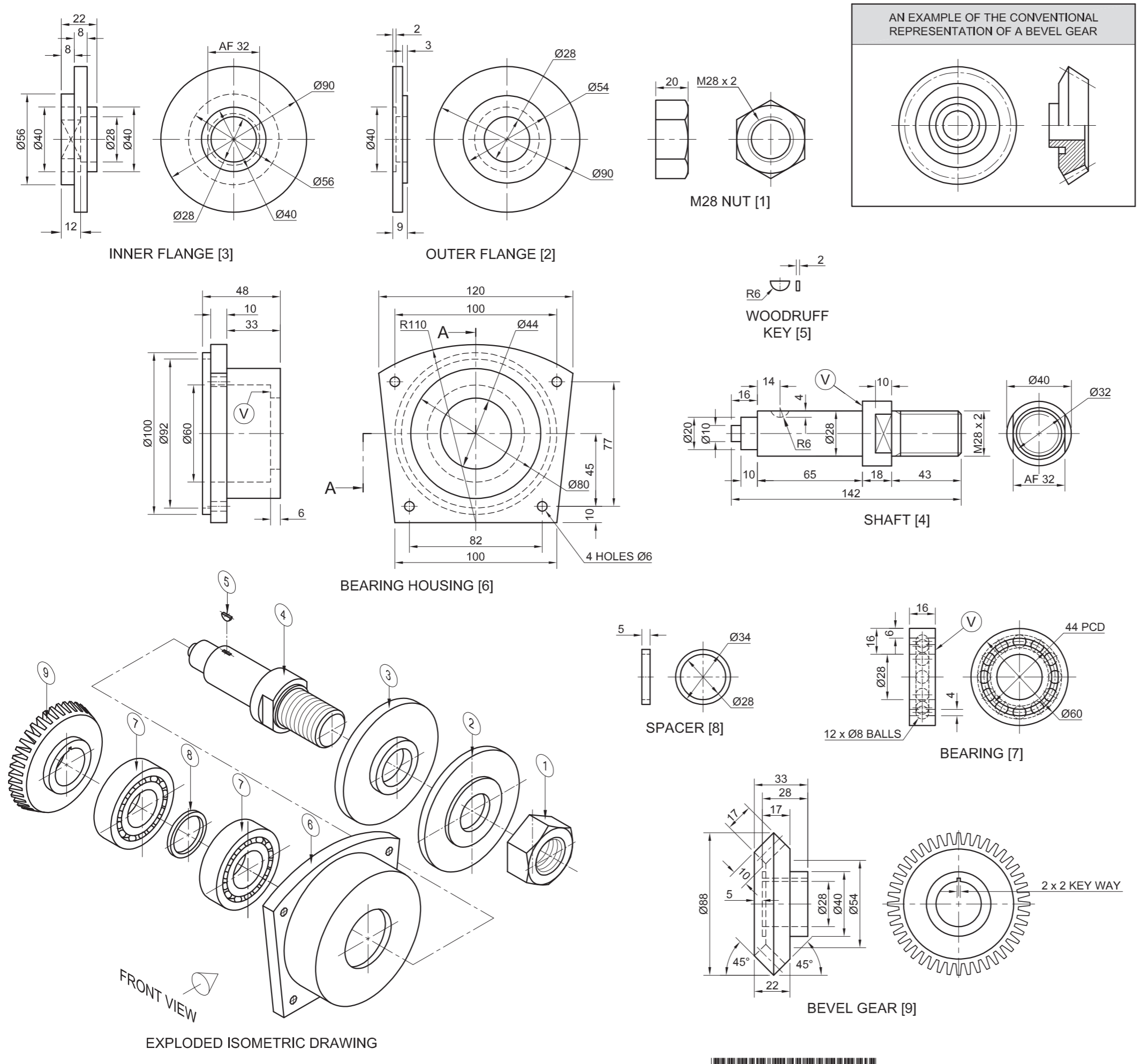

QUESTION 4: MECHANICAL ASSEMBLY

- Given:**
- The exploded isometric drawing of the parts of a shaft assembly, showing the position of each part relative to all the others
 - Orthographic views of each part of the shaft assembly
 - An example of the conventional representation of a bevel gear

- Instructions:**
- Answer this question on page 6.
 - Draw, to scale 1 : 1 and in third-angle orthographic projection, the following views of the assembled parts of the shaft assembly:
 - 4.1 **A half-sectional front view** on cutting plane A-A. Show the top half in section, as seen from the direction of the arrow on the exploded isometric drawing. The cutting plane is shown on the right view of the bearing housing (part 6).
 - 4.2 **The right view**

- NOTE:**
- Planning is essential.
 - The drawing must comply with the guidelines as contained in the SANS 10111.
 - The convention of symmetry may NOT be applied.
 - The surfaces marked **V** on the shaft (part 4) and the right bearing (part 7), must be aligned with the surface marked **V** on the inside of bearing housing (part 6).
 - Show **THREE** faces of the M28 nut (part 1) in the half-sectional front view.
 - Draw the **left** bearing in detail and the **right** bearing as a convention representation.
 - Add cutting plane A-A.
 - **NO** hidden detail is required.

[93]

PARTS LIST			
	PART	QUANTITY	MATERIAL
1	M28 NUT	1	MILD STEEL
2	OUTER FLANGE	1	MILD STEEL
3	INNER FLANGE	1	MILD STEEL
4	SHAFT	1	TOOL STEEL
5	WOODRUFF KEY	1	TOOL STEEL
6	BEARING HOUSING	1	PEWTER
7	BEARING	2	TOOL STEEL
8	SPACER	1	MILD STEEL
9	BEVEL GEAR	1	TOOL STEEL

GSP
SHAFTS AND GEARS

CYLINDER STREET
INDUSTRIAL PARK
www.shaftsgalore.co.za

SHAFT ASSEMBLY

ALL DIMENSIONS ARE IN MILLIMETRES

5



FOR OFFICIAL USE ONLY	
INCORRECT ORTHOGRAPHIC PROJECTION	
INCORRECT OVERALL SCALE	
INCORRECT HATCHING	
PARTS NOT ASSEMBLED	
TOTAL PENALTIES (-)	

ASSESSMENT CRITERIA					
RIGHT VIEW					
		POSSIBLE	OBTAINED	SIGN	MODERATED
1	BODY	4½			
2	SHAFT	1½			
3	M28 NUT + FLANGE	3½			
SUBTOTAL		9½			
HALF SECTIONAL FRONT VIEW					
1	BODY	13			
2	SHAFT + KEY	16			
3	BEARING + SPACER	9			
4	FLANGES	13			
5	M28 NUT	4½			
6	GEAR	11			
SUBTOTAL		66½			
GENERAL					
1	CENTRE LINES	4			
2	CUTTING PLANE A-A	4			
3	ASSEMBLY	9			
SUBTOTAL		17			
TOTAL		93			
PENALTIES (-)					
GRAND TOTAL					
EXAMINATION NUMBER					
EXAMINATION NUMBER					
EXAMINATION NUMBER					



AN EXAMPLE OF THE CONVENTIONAL REPRESENTATION OF A SPUR GEAR

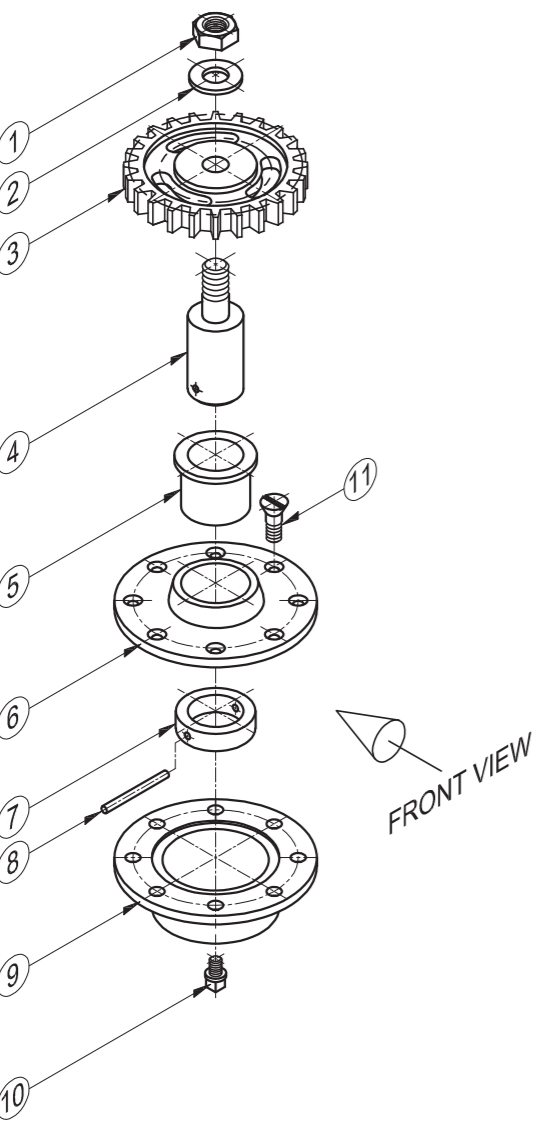
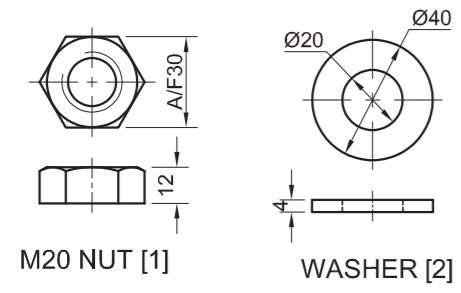
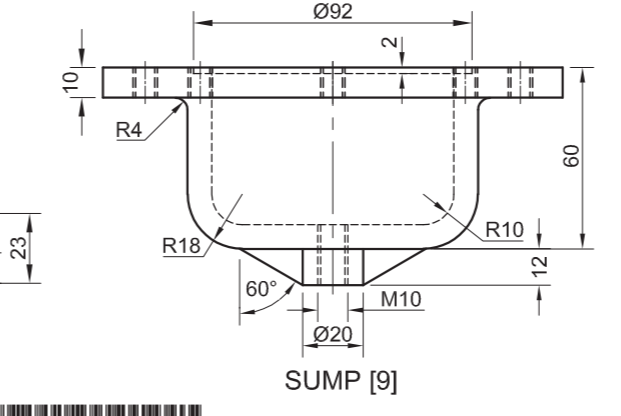
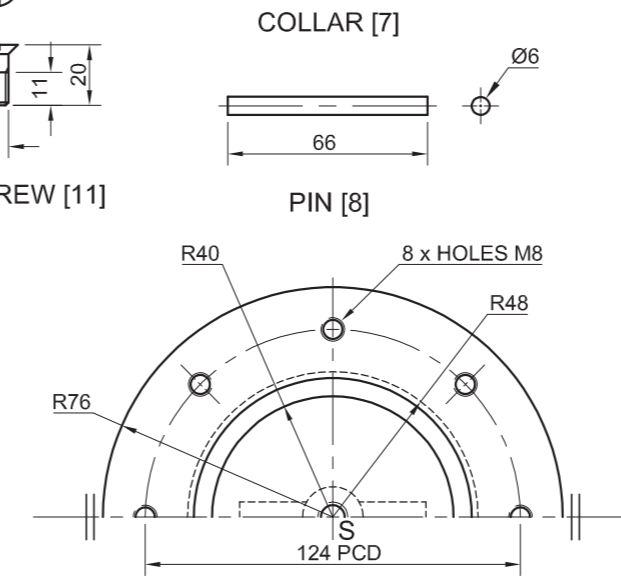
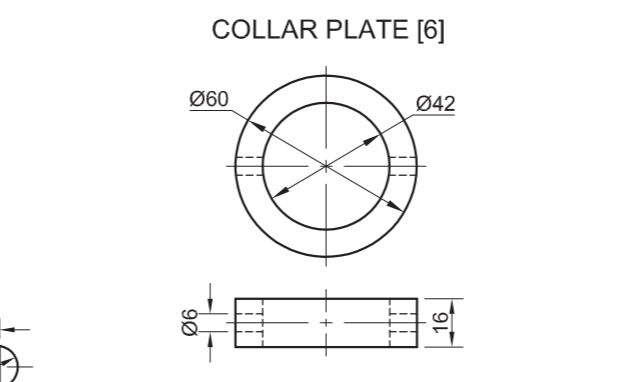
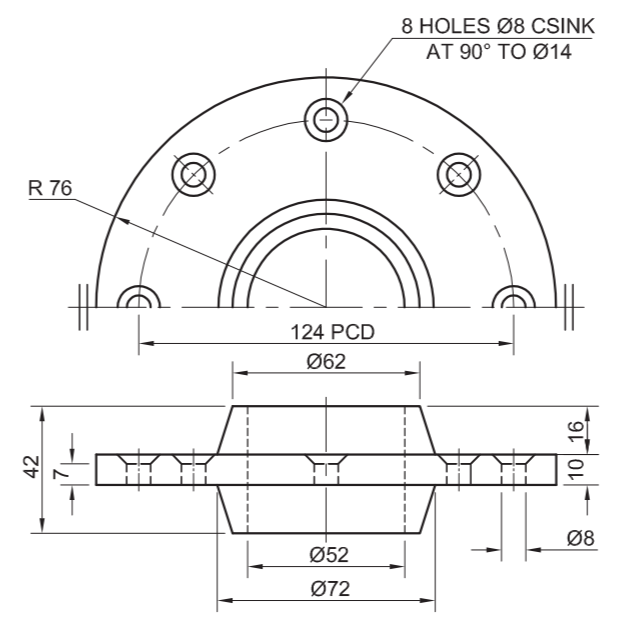
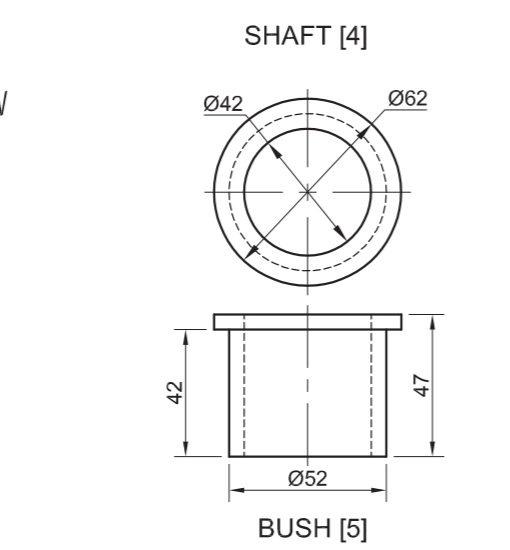
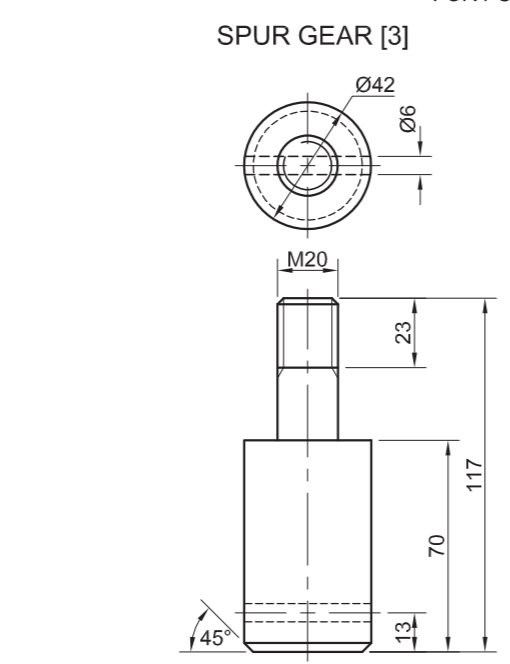
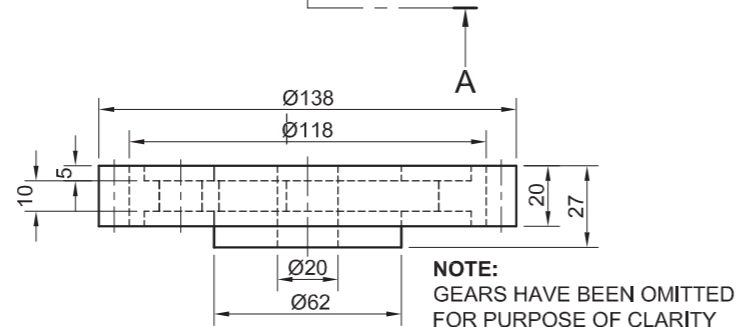
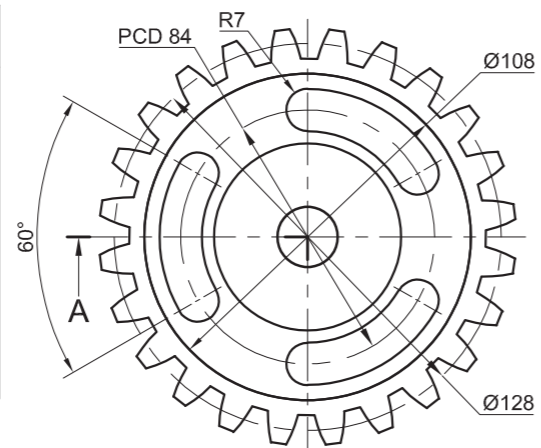
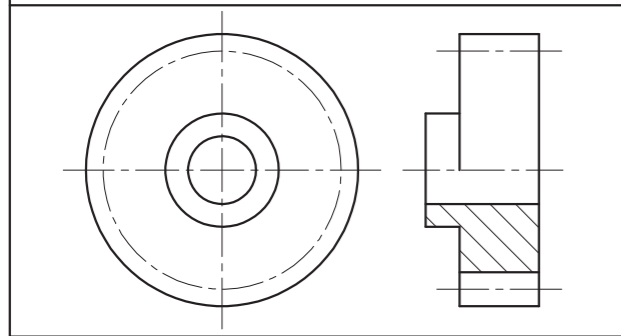

EXPLODED ISOMETRIC DRAWING

QUESTION 4: ASSEMBLY DRAWING

Given:

- The exploded isometric drawing of the parts of a gear and sump assembly, showing the position of each part relative to all the others
- Orthographic views of each of the parts of the gear and sump assembly
- An example of the conventional representation of a spur gear

Instructions:

- Answer this question on page 6.
- Draw, to scale 1 : 1 and in third-angle orthographic projection, the following views of the assembled parts of the gear and sump assembly:
 - 4.1 A half-sectional front view** on cutting plane A-A. Show the left half in section, as seen from the direction of the arrow on the exploded isometric drawing. The cutting plane is shown on the top view of the spur gear (part 3).
 - 4.2 The top view.** Show only the top half of the top view by applying the convention for the presentation of a symmetrical object.

NOTE:

- Planning is essential.
- ALL drawings must comply with the guidelines as contained in the SANS 10111.
- Show THREE faces of the M20 nut (part 1).
- Draw the conventional representation of the spur gear (part 3) in both views.
- NO hidden detail is required.

[93]

PARTS LIST			
PART	QUANTITY	MATERIAL	
1	M20 NUT	1	MILD STEEL
2	WASHER	1	MILD STEEL
3	SPUR GEAR	1	CAST IRON
4	SHAFT	1	CAST IRON
5	BUSH	1	MILD STEEL
6	COLLAR PLATE	1	MILD STEEL
7	COLLAR	1	MILD STEEL
8	PIN	1	MILD STEEL
9	SUMP	1	CAST IRON
10	PLUG	1	CAST IRON
11	M8 SCREW	8	MILD STEEL

CASTFORM
ENGINEERING (PTY) LTD
98 BROAD STREET
MIDDELFRONTEIN
4070
www.foundry.co.za

GEAR AND SUMP ASSEMBLY

ALL DIMENSIONS ARE IN MILLIMETRES ALL UNSPECIFIED RADII ARE 3 mm

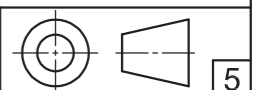



FOR OFFICIAL USE ONLY	
INCORRECT OVERALL SCALE	
INCORRECT HATCHING	
PARTS NOT ASSEMBLED	
TOTAL PENALTIES (-)	

ASSESSMENT CRITERIA					
TOP VIEW					
		POSSIBLE	OBTAINED	SIGN	MODERATED
1	GEAR	6			
2	COLLAR PLATE	$\frac{1}{2}$			
3	M20 NUT + WASHER	$4\frac{1}{2}$			
4	SYMMETRY	1			
SUBTOTAL		12			
SECTIONAL FRONT VIEW					
1	SUMP	$16\frac{1}{2}$			
2	PLUG	7			
3	COVER PLATE	$4\frac{1}{2}$			
4	BUSH	3			
5	COLLAR + PIN	5			
6	SHAFT	$9\frac{1}{2}$			
7	GEAR	10			
8	M20 NUT + WASHER	$6\frac{1}{2}$			
9	M8 SCREW	6			
SUBTOTAL		68			
GENERAL					
1	CENTRE LINES	3			
2	ASSEMBLY	10			
SUBTOTAL		13			
TOTAL		93			
PENALTIES (-)					
GRAND TOTAL					
EXAMINATION NUMBER					
EXAMINATION NUMBER					
6					



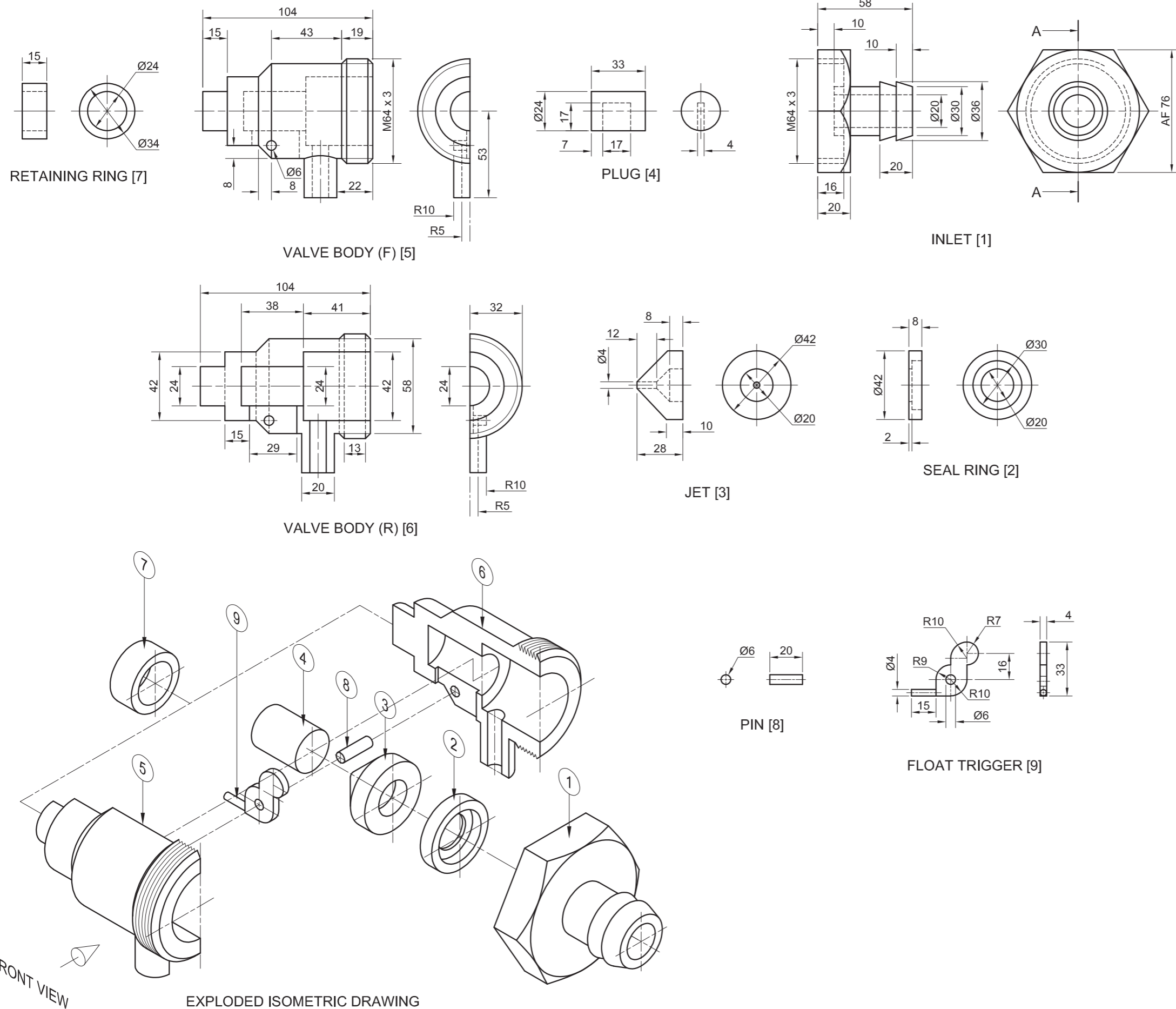

QUESTION 4: MECHANICAL ASSEMBLY

Given:

- The exploded isometric drawing of the parts of a float control assembly, showing the position of each part relative to all the others
- Orthographic views of each of the parts of the float control assembly

Instructions:

- Answer this question on page 6.
- Draw, to scale 1 : 1 and in third-angle orthographic projection, the following views of the assembled parts of the float control assembly:
 - 4.1 A sectional front view on cutting plane A-A, as seen from the direction of the arrow shown on the exploded isometric drawing. The cutting plane is shown on the right view of the inlet (part 1).

- 4.2 The right view
- 4.3 The bottom view

NOTE:

- Planning is essential.
- ALL drawings must comply with the guidelines as contained in the SANS 10111.
- The convention of symmetry may NOT be applied.
- Show THREE faces of the inlet in the bottom view.
- The plug (part 4) must be placed against the jet (part 3).
- Add cutting plane A-A in the right view.
- NO hidden detail is required. [94]

PARTS LIST			
PART	QUANTITY	MATERIAL	
1	INLET	1	PLASTIC
2	SEAL RING	1	RUBBER
3	JET	1	LTA PLASTIC
4	PLUG	1	PLASTIC
5	VALVE BODY (F)	1	PLASTIC
6	VALVE BODY (R)	1	PLASTIC
7	RETAINING RING	1	PLASTIC
8	PIN	1	PLASTIC
9	FLOAT TRIGGER	1	PLASTIC

TITLE	WR	8 QUARRY STREET
	PROJECTS	DELTA PARK 1807
		www.waterproducts.co.za
		012 543 6879

TITLE	FLOAT CONTROL		5
-------	---------------	--	---



FOR OFFICIAL USE ONLY	
INCORRECT ORTHOGRAPHIC PROJECTION	
INCORRECT OVERALL SCALE	
INCORRECT HATCHING	
PARTS NOT ASSEMBLED	
TOTAL PENALTIES (-)	

ASSESSMENT CRITERIA					
RIGHT VIEW					
		POSSIBLE	OBTAINED	SIGN	MODERATED
1	INLET + JET	4			
2	VALVE BODY	2			
SUBTOTAL		6			
SECTIONAL FRONT VIEW					
1	INLET	14 $\frac{1}{2}$			
2	SEAL RING	2			
3	VALVE BODY + RETAINING RING	22			
4	JET	6 $\frac{1}{2}$			
5	FLOAT TRIGGER + PIN + PLUG	9			
SUBTOTAL		54			
BOTTOM VIEW					
1	INLET	9 $\frac{1}{2}$			
2	VALVE BODY + RETAINING RING + JET	9 $\frac{1}{2}$			
SUBTOTAL		19			
GENERAL					
1	CENTRE LINES	4			
2	SECTION A-A	3			
3	ASSEMBLY	8			
SUBTOTAL		15			
TOTAL		94			
PENALTIES (-)					
GRAND TOTAL					
EXAMINATION NUMBER					
EXAMINATION NUMBER					
6					



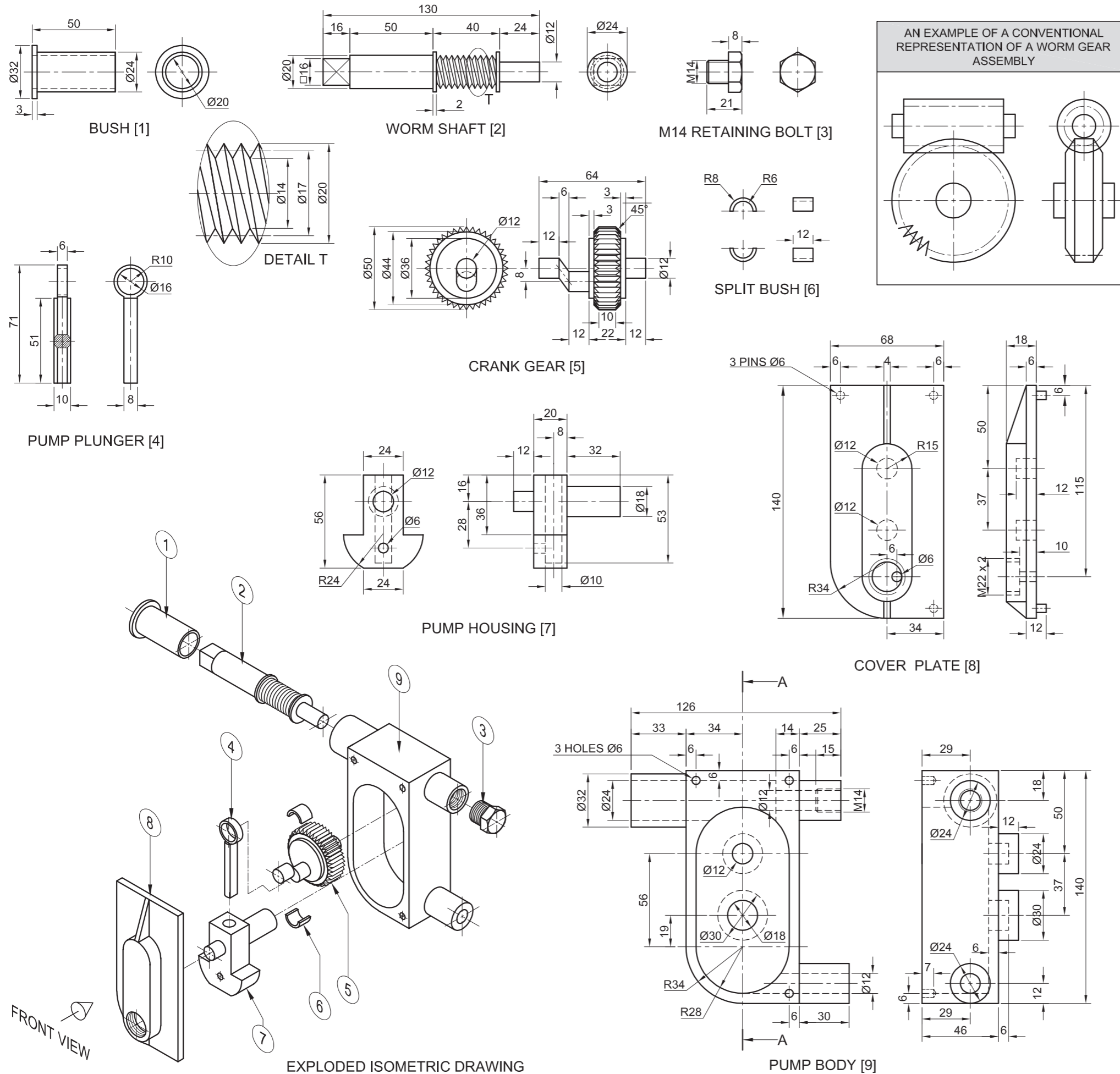

QUESTION 4: MECHANICAL ASSEMBLY

Given:

- The exploded isometric drawing of the parts of an oil pump assembly, showing the position of each part relative to all the others
- Orthographic views of each of the parts of the oil pump assembly
- An example of a conventional representation of a worm gear assembly.

Instructions:

- Answer this question on page 6.
- Draw, to scale 1 : 1 and in third-angle orthographic projection, the following views of the assembled parts of the oil pump assembly:
 - 4.1 **The front view** as seen from the direction of the arrow shown on the exploded isometric drawing.
 - 4.2 **A sectional right view** on cutting plane A-A. The cutting plane, which passes vertically through the oil pump assembly, is shown on the front view of the pump body (part 9).

NOTE:

- Planning is essential.
- The drawing must comply with the guidelines as contained in the *SANS 10111*.
- Show **THREE** faces of the M14 retaining bolt (part 3) in the front view.
- Draw a conventional representation of the worm gear assembly in the sectional right view.
- Add cutting plane A-A.
- **NO** hidden detail is required.

[96]

PARTS LIST			
	PARTS	QUANTITY	MATERIAL
1	BUSH	1	BRONZE
2	WORM SHAFT	1	EN 8
3	M14 RETAINING BOLT	1	BRASS
4	PUMP PLUNGER	1	BRASS
5	CRANK GEAR	1	EN 19
6	SPLIT BUSH	2	BRONZE
7	PUMP HOUSING	1	BRASS
8	COVER PLATE	1	MILD STEEL
9	PUMP BODY	1	STAINLESS STEEL

BVJ
PROJECTS CC

101 FLAMINGO
INDUSTRIAL PARK
www.BVJ.co.za
012 345 6789

OIL PUMP

ALL DIMENSIONS ARE IN MILLIMETRES.

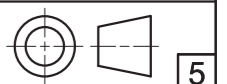

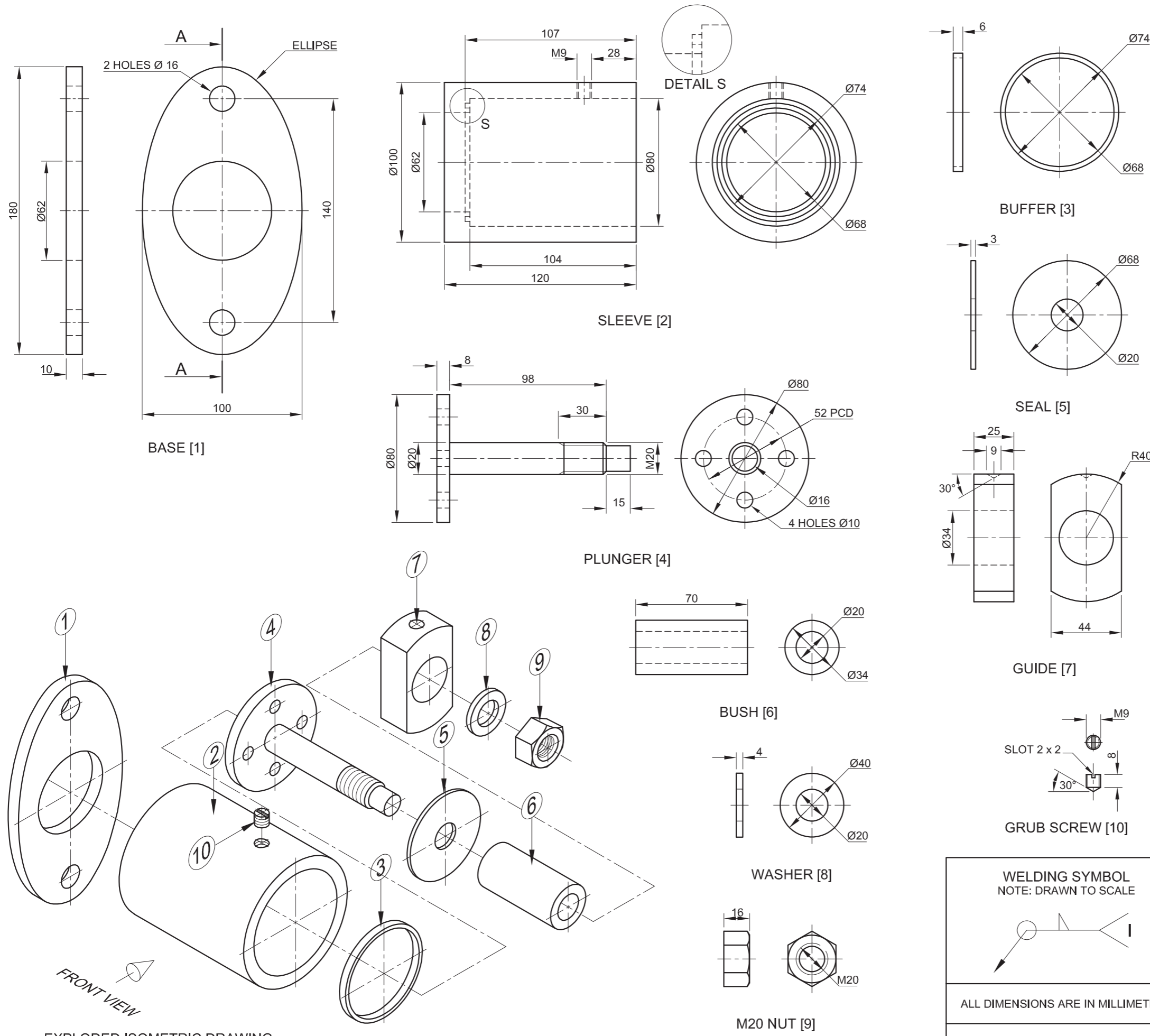

QUESTION 4: MECHANICAL ASSEMBLY

Given:

- The exploded isometric drawing of the parts of a sleeve valve assembly, showing the position of each part relative to all the others
- Orthographic views of each of the parts of the sleeve valve assembly

Instructions:

- Answer this question on page 6.
- Draw, to scale 1 : 1 and in third-angle orthographic projection, the following views of the assembled parts of the sleeve valve assembly:
 - 4.1 **A sectional front view** on cutting plane A-A, as seen from the direction of the arrow shown on the exploded isometric drawing. The cutting plane is shown on the right view of the base (part 1).
 - 4.2 **The right view.** Show ALL hidden detail.

NOTE:

- Planning is essential.
- ALL drawings must comply with the guidelines as contained in the *SANS 10111*.
- The convention of symmetry may NOT be applied.
- The sleeve (part 2) must be placed against the base (part 1) and welded in place. Show the given welding symbol on the sectional front view.
- The plunger (part 4) must be drawn in position against the buffer (part 3).
- Show THREE faces of the M20 nut in the front view.
- Add cutting plane A-A.
- NO hidden detail is required on the front view. [90]

PARTS LIST		
PART	QUANTITY	MATERIAL
1	1	STAINLESS STEEL
2	1	STAINLESS STEEL
3	1	RUBBER
4	1	STAINLESS STEEL
5	1	RUBBER
6	1	BRASS
7	1	STAINLESS STEEL
8	1	STAINLESS STEEL
9	1	STAINLESS STEEL
10	1	STAINLESS STEEL

WC
PATENTS

FARMER IDEAS
NAMPO
www.nampo.co.za

TITLE: **SLEEVE VALVE**





FOR OFFICIAL USE ONLY	
INCORRECT ORTHOGRAPHIC PROJECTION	
INCORRECT OVERALL SCALE	
INCORRECT HATCHING	
PARTS NOT ASSEMBLED	
TOTAL PENALTIES (-)	

ASSESSMENT CRITERIA					
RIGHT VIEW					
		POSSIBLE	OBTAINED	SIGN	MODERATED
1	BASE	6			
2	SLEEVE	1			
3	PLUNGER	1			
4	SEAL	1/2			
5	GUIDE	1			
6	NUT + WASHER	3			
7	HIDDEN DETAIL	6 1/2			
SUBTOTAL		19			
SECTIONAL FRONT VIEW					
1	BASE	7			
2	SLEEVE + GRUB SCREW	11 1/2			
3	BUFFER	5			
4	PLUNGER	14			
5	SEAL	3			
6	BUSH	2			
7	GUIDE	3			
8	NUT + WASHER	6			
SUBTOTAL		51 1/2			
GENERAL					
1	CENTRE LINES	4			
2	ASSEMBLY	9			
3	CUTTING PLANE	3			
4	WELDING SYMBOL	3 1/2			
SUBTOTAL		19 1/2			
TOTAL		90			
PENALTIES (-)					
GRAND TOTAL					
EXAMINATION NUMBER					
EXAMINATION NUMBER					
EXAMINATION NUMBER					



QUESTION 4: MECHANICAL ASSEMBLY

Given:

- The exploded isometric drawing of the parts of a pipe clamp assembly, showing the position of each part relative to all the others
- Orthographic views of each of the parts of the pipe clamp assembly

Instructions:

- Answer this question on page 6.
- Draw, to scale 1 : 1 and in third-angle orthographic projection, the following views of the assembled parts of the pipe clamp assembly:
 - 4.1 A half-sectional front view** on cutting plane A-A. Show the left side in section, as seen from the direction of the arrow shown on the exploded isometric drawing. The cutting plane is shown on the top view of the base (part 1).
 - 4.2 The top view**

NOTE:

- Planning is essential.
- ALL drawings must comply with the guidelines as contained in the *SANS 10111*.
- The convention of symmetry may not be applied.
- The worm screw (part 7) must be completely screwed into the frame (part 2) so that point S will be at the indicated position.
- The lever (part 8) must be placed in the centre of the worm screw (part 7).
- In the top view, draw only the right-side M10 bolt. Show TWO faces of the bolt.
- Add cutting plane A-A.
- NO hidden detail is required.

[96]

PARTS LIST		
PART	QUANTITY	MATERIAL
1	BASE	CAST IRON
2	FRAME	MILD STEEL
3	PIN	MILD STEEL
4	HOOK	MILD STEEL
5	JAW	TOOL STEEL
6	M10 BOLT	TOOL STEEL
7	WORM SCREW	HARDENED STEEL
8	LEVER	HARDENED STEEL

WR PROJECTS	8 VON WHEILIG STREET ALIES PARK 1791 www.sn_king.co.za 069 313 1574
	TITLE PIPE CLAMP

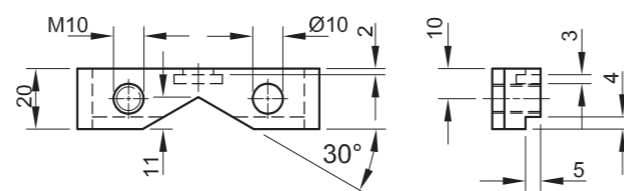
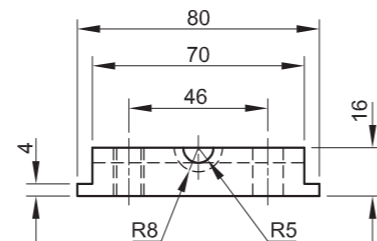
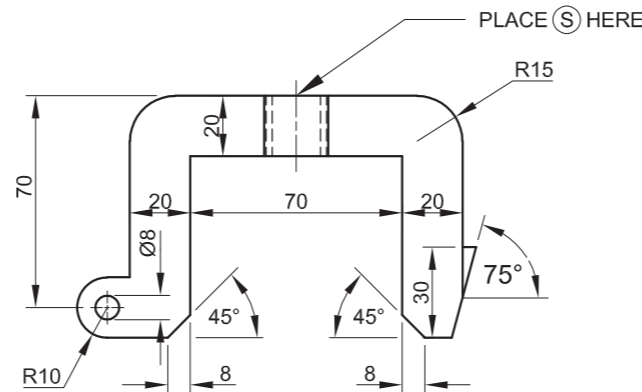
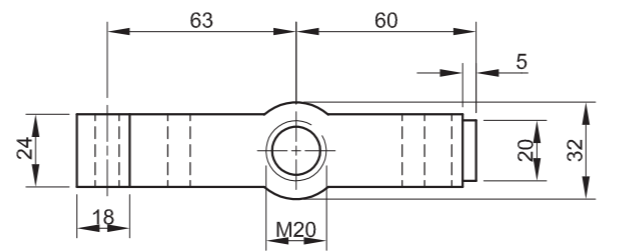
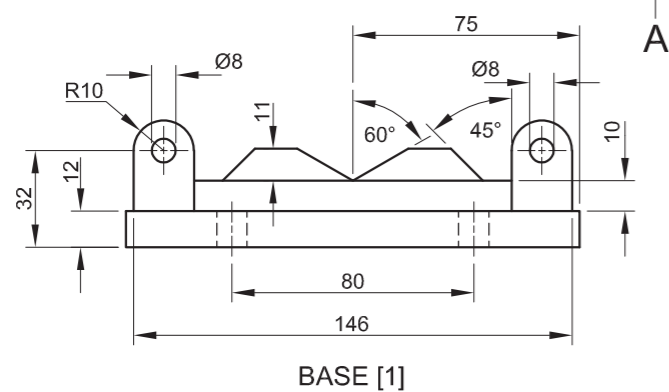
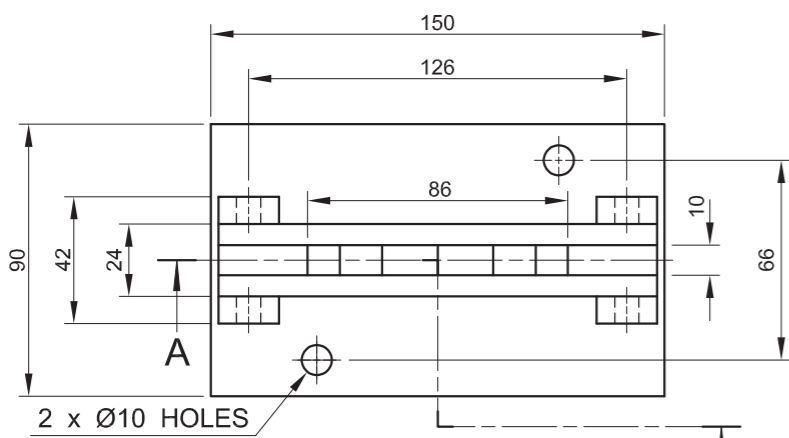

JAW [5]

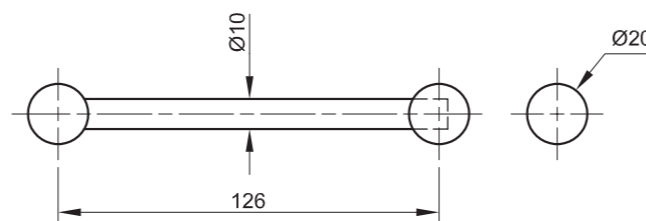

LEVER [8]

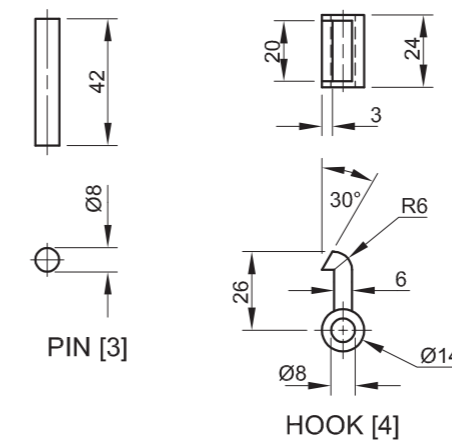

HOOK [4]

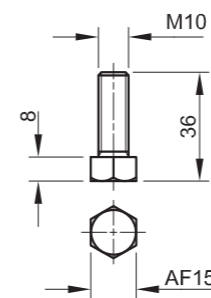

M10 BOLT [6]

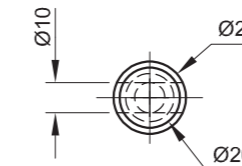

WORM SCREW [7]

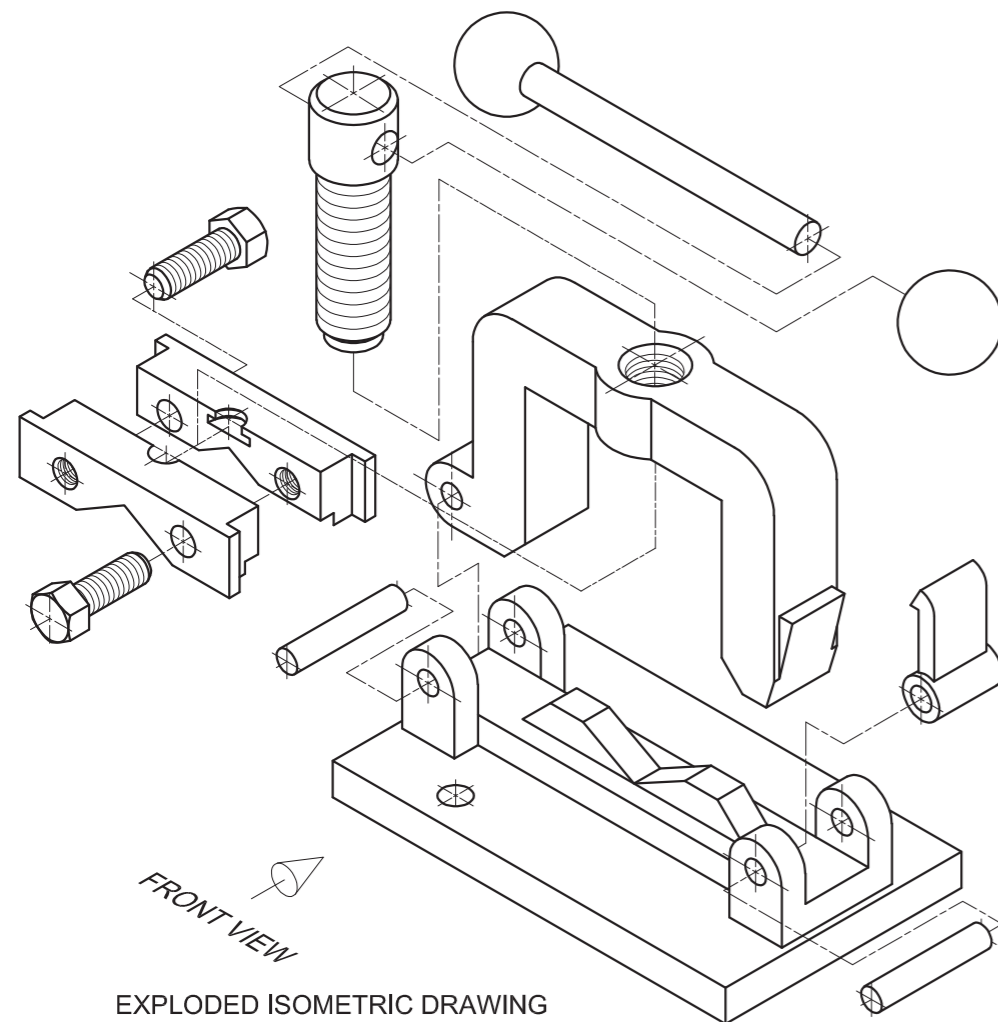

EXPLODED ISOMETRIC DRAWING

ALL DIMENSIONS ARE IN MILLIMETRES	DRAWN: WILLEM DATE: 10/11/2016
FILLETS ARE R3 AND ROUNDINGS ARE R5	DRAWING PROGRAM: CAD 2016

TITLE PIPE CLAMP	
----------------------------	--





FOR OFFICIAL USE ONLY	
INCORRECT ORTHOGRAPHIC PROJECTION	
INCORRECT OVERALL SCALE	
INCORRECT HATCHING	
PARTS NOT ASSEMBLED	
TOTAL PENALTIES (-)	

ASSESSMENT CRITERIA					
TOP VIEW					
		POSSIBLE	OBTAINED	SIGN	MODERATED
1	BASE	8			
2	FRAME	5			
3	HOOK	5			
4	JAW + M10 BOLT	6½			
5	WORM SCREW + LEVER	4			
SUBTOTAL		28½			
SECTIONAL FRONT VIEW					
1	BASE	9½			
2	FRAME	8			
3	PINS + HOOK	3½			
4	JAW + M10 BOLT	9½			
5	WORM SCREW	9½			
6	LEVER	3			
SUBTOTAL		43			
GENERAL					
1	CENTRE LINES	10½			
2	ASSEMBLY	9			
3	CUTTING PLANE	5			
SUBTOTAL		24½			
TOTAL		96			
PENALTIES (-)					
GRAND TOTAL					
EXAMINATION NUMBER					
EXAMINATION NUMBER				6	



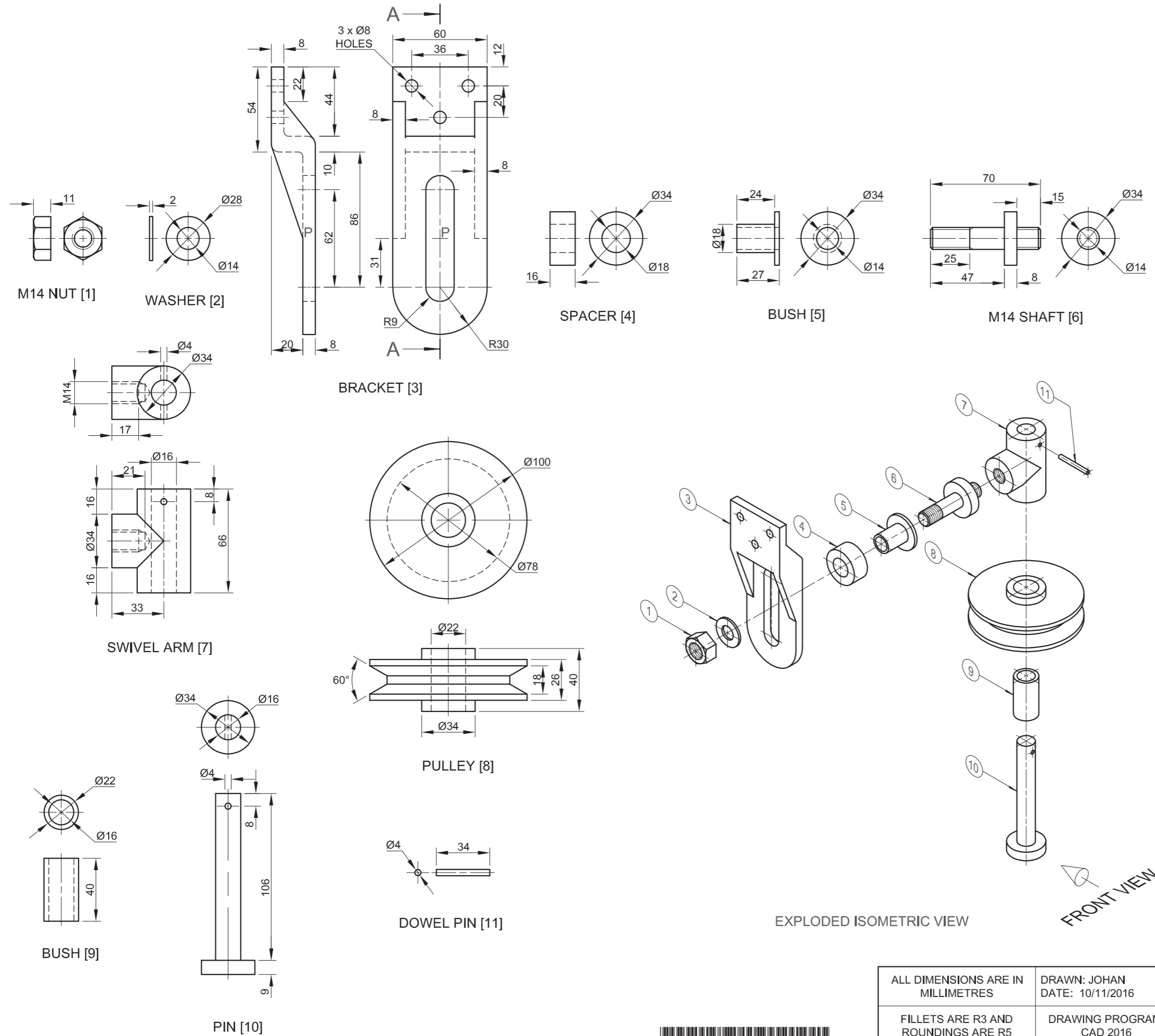

QUESTION 4: MECHANICAL ASSEMBLY

Given:

- Orthographic views of each of the parts of a swivel pulley assembly
- The exploded isometric drawing of the parts of a swivel pulley assembly, showing the position of each part relative to all the others

Instructions:

- Answer this question on page 6.
- Draw, to scale 1 : 1 and in third-angle orthographic projection, the following views of the assembled parts of the swivel pulley assembly:
 - 4.1 A sectional front view on cutting plane A-A, as seen from the direction of the arrow shown on the exploded isometric drawing. The cutting plane is shown on the right view of the bracket (part 3).
 - 4.2 The right view

NOTE:

- Layout planning is essential.
- ALL drawings must comply with the guidelines as contained in the SANS 10111.
- The convention of symmetry may not be applied.
- Place the M14 shaft (part 6) at point P in the centre of the slotted groove of the bracket (part 3).
- Show THREE faces of the M14 nut in the front view.
- No hidden detail is required.
- Add cutting plane A-A.

[88]

PARTS LIST			
	PART	QUANTITY	MATERIAL
1	M14 NUT	1	MILD STEEL
2	WASHER	1	MILD STEEL
3	BRACKET	1	MILD STEEL
4	SPACER	1	MILD STEEL
5	BUSH	1	BRASS
6	M14 SHAFT	1	MILD STEEL
7	SWIVEL ARM	1	MILD STEEL
8	PULLEY	1	CAST IRON
9	BUSH	1	BRASS
10	PIN	1	MILD STEEL
11	DOWEL PIN	1	MILD STEEL

ALL DIMENSIONS ARE IN MILLIMETRES	DRAWN: JOHAN DATE: 10/11/2016	APULLEY MANUFACTURING		MAIN STREET GEORGE 6520 www.apm.co.za
FILLETS ARE R3 AND ROUNDTINGS ARE R5	DRAWING PROGRAM: CAD 2016	TITLE SWIVEL PULLEY		5





FOR OFFICIAL USE ONLY		
NOT IN THIRD ANGLE		
INCORRECT OVERALL SCALE		
INCORRECT HATCHING		
PARTS NOT ASSEMBLED		
PARTS DRAWN IN FREEHAND		
PENALTY TOTAL (-)		

ASSESSMENT CRITERIA					
RIGHT VIEW					
		POSSIBLE	OBTAINED	SIGN	MODERATED
1	BRACKET	7			
2	SWIVEL ARM	2			
3	PULLEY	4			
4	M14 SHAFT	2			
SUBTOTAL		15			
SECTIONAL FRONT VIEW					
1	M14 NUT	5			
2	WASHER	2			
3	BRACKET	14			
4	SPACER	2			
5	BUSH	2			
6	M14 SHAFT	9			
7	SWIVEL ARM	8 ¹ / ₂			
8	PULLEY	5 ¹ / ₂			
9	BUSH	2			
10	SHAFT + PIN	4			
SUBTOTAL		54			
GENERAL					
1	CENTRE LINES	6			
2	ASSEMBLY	10			
3	CUTTING PLANE	3			
SUBTOTAL		19			
TOTAL		88			
PENALTY(-)					
GRAND TOTAL					
EXAMINATION NUMBER					
EXAMINATION NUMBER					
6					



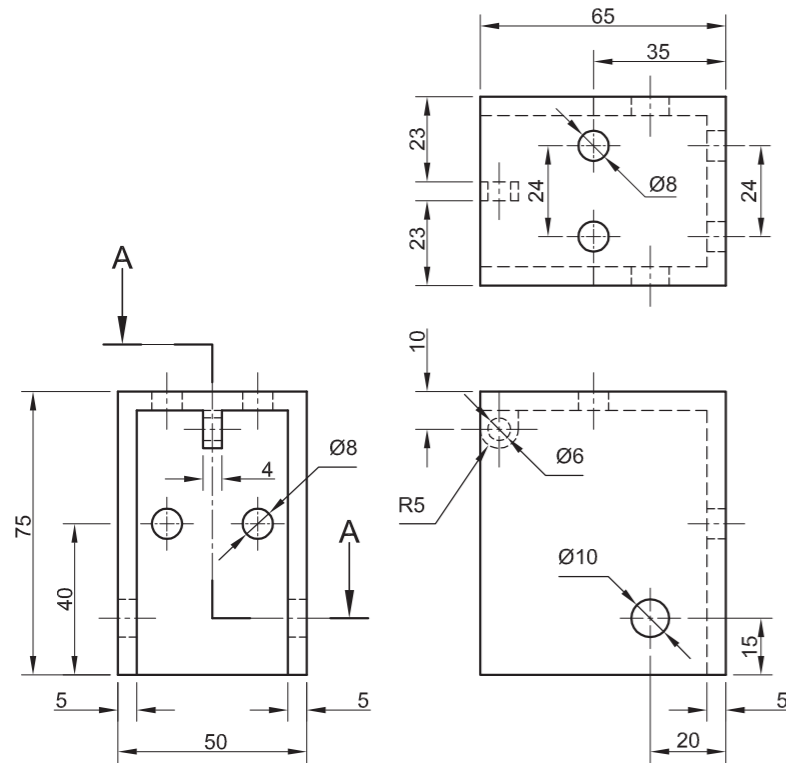

HOUSING [1]

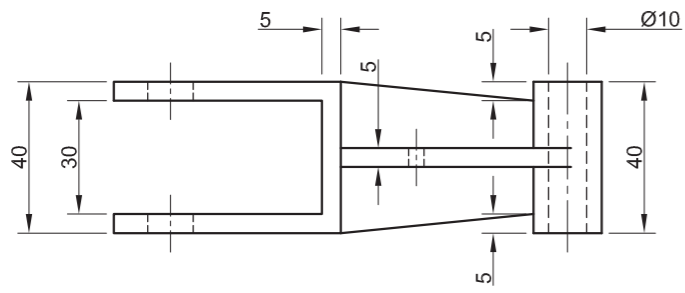

FORK [2]

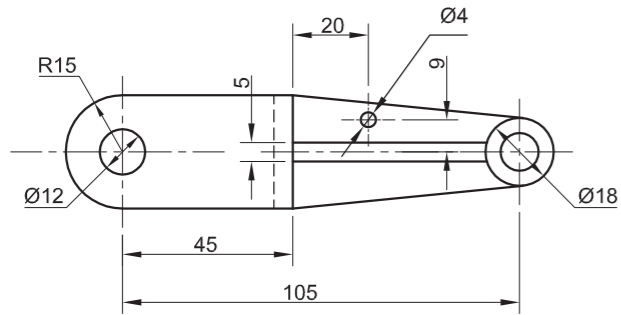

PIN [3]

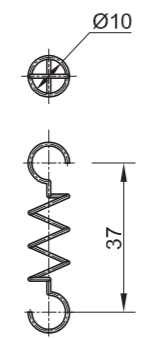

SPRING [4]

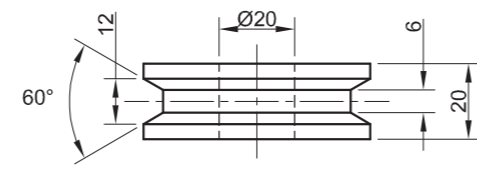

PULLEY [7]

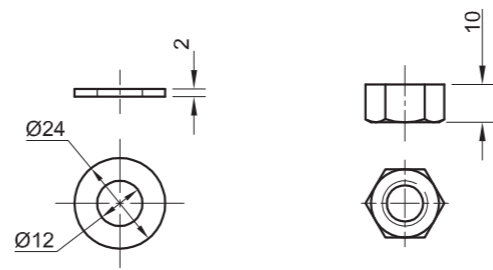

WASHER [8]

M12 NUT [9]

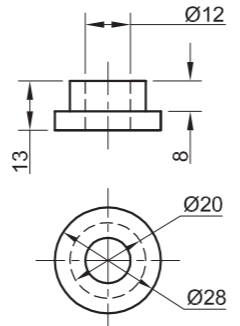

BUSH [6]

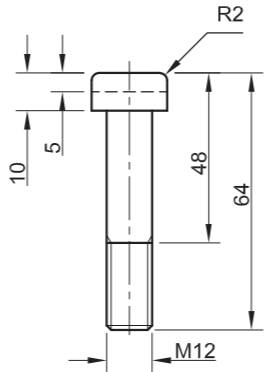

M12 BOLT [5]

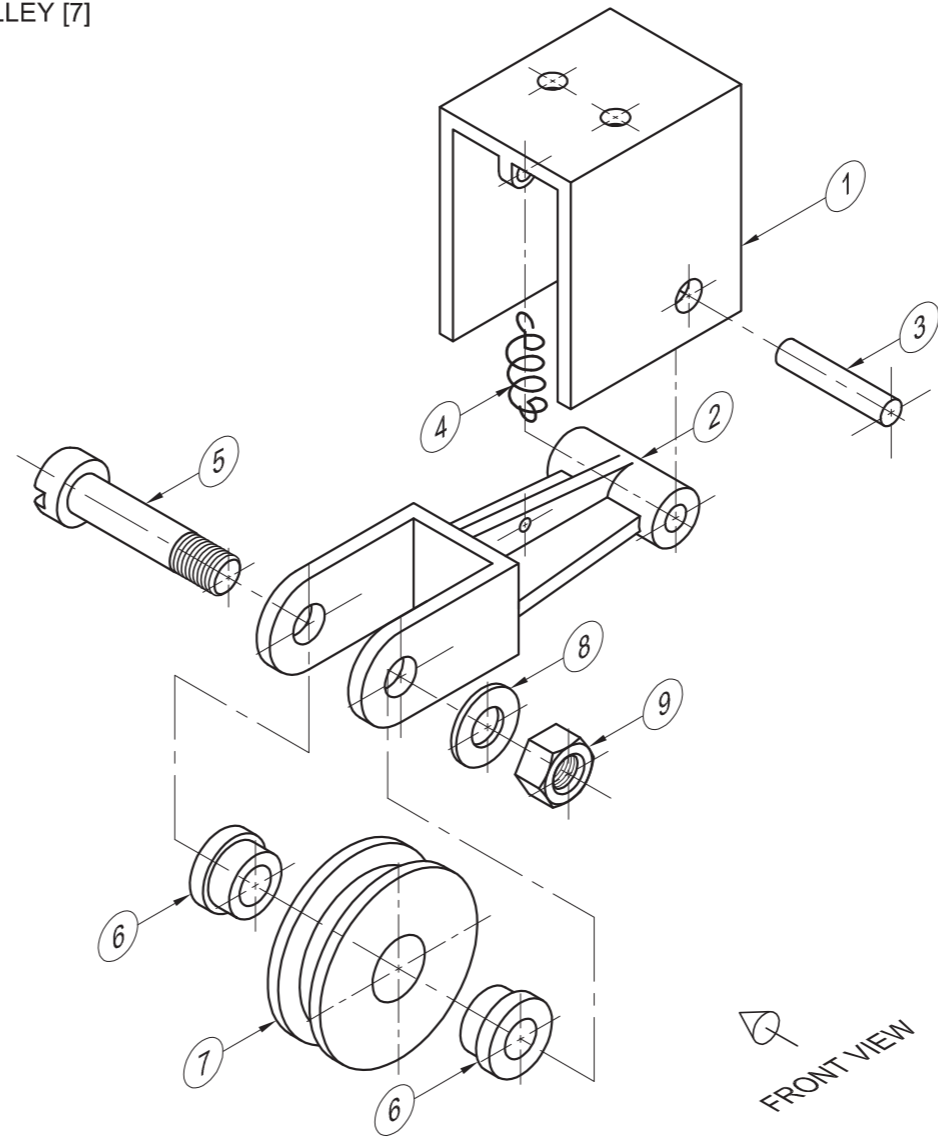

EXPLODED ISOMETRIC DRAWING

FRONT VIEW

QUESTION 4: MECHANICAL ASSEMBLY

Given:

- Orthographic views of each of the parts of a tension pulley assembly
- The exploded isometric drawing of the parts of the tension pulley assembly, showing the position of each part relative to all the others

Instructions:

- Answer this question on page 6.
- Draw, to scale 1 : 1 and in third-angle orthographic projection, the following views of the assembled parts of the tension pulley assembly:
 - 4.1 The front view as seen from the direction of the arrow shown on the exploded isometric drawing
 - 4.2 A half-sectional top view on cutting plane A-A. Show the front half in section, in accordance with the cutting plane that is shown on the left view of the housing (part 1).
 - 4.3 The left view

NOTE:

- Planning is essential.
- ALL drawings must comply with the guidelines contained in the SANS 10111.
- The convention of symmetry may not be applied.
- The spring (part 4) must be drawn in convention and in neat freehand.
- Show THREE faces of the M12 nut in the top view.
- Add cutting plane A-A.
- NO hidden detail is required.

[92]

PARTS LIST			
PART	QUANTITY	MATERIAL	
1	HOUSING	1	MILD STEEL
2	FORK	1	CAST IRON
3	PIN	1	MILD STEEL
4	SPRING	1	SPRING STEEL
5	M12 BOLT	1	MILD STEEL
6	BUSH	2	BRASS
7	PULLEY	1	CAST IRON
8	WASHER	1	MILD STEEL
9	M12 NUT	1	MILD STEEL

TITLE
TENSION PULLEY
GENERAL
 ENGINEERING WORKS
 54 PEARL ROAD
 PERSEVERANCE
 6000
 041 335 1600

ALL DIMENSIONS ARE IN MILLIMETRES. ALL UNSPECIFIED RADII ARE R5.

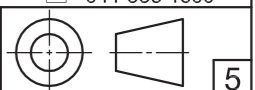



FOR OFFICIAL USE ONLY	
INCORRECT ORTHOGRAPHIC PROJECTION	
INCORRECT SCALE	
INCORRECT HATCHING	
PARTS NOT ASSEMBLED	
TOTAL PENALTIES (-)	

ASSESSMENT CRITERIA			
FRONT VIEW			
1	HOUSING + PIN	3	
2	FORK	4	
3	PULLEY	1	
4	M12 BOLT + WASHER + M12 NUT	6	
SUBTOTAL		14	
SECTIONAL TOP VIEW			
1	HOUSING + PIN	7	
2	FORK	10 $\frac{1}{2}$	
3	M12 BOLT	7	
4	BUSH	4	
5	PULLEY	7 $\frac{1}{2}$	
6	WASHER + M12 NUT	4 $\frac{1}{2}$	
SUBTOTAL		40 $\frac{1}{2}$	
LEFT VIEW			
1	HOUSING	4 $\frac{1}{2}$	
2	FORK	1 $\frac{1}{2}$	
3	SPRING	2	
4	BUSH	1	
5	PULLEY	4 $\frac{1}{2}$	
6	M12 BOLT + WASHER + M12 NUT	8 $\frac{1}{2}$	
SUBTOTAL		22	
GENERAL			
1	CENTRE LINES	6 $\frac{1}{2}$	
2	ASSEMBLY	9	
SUBTOTAL		15 $\frac{1}{2}$	
TOTAL		92	
PENALTIES (-)			
GRAND TOTAL			
EXAMINATION NUMBER			
EXAMINATION NUMBER			
6			



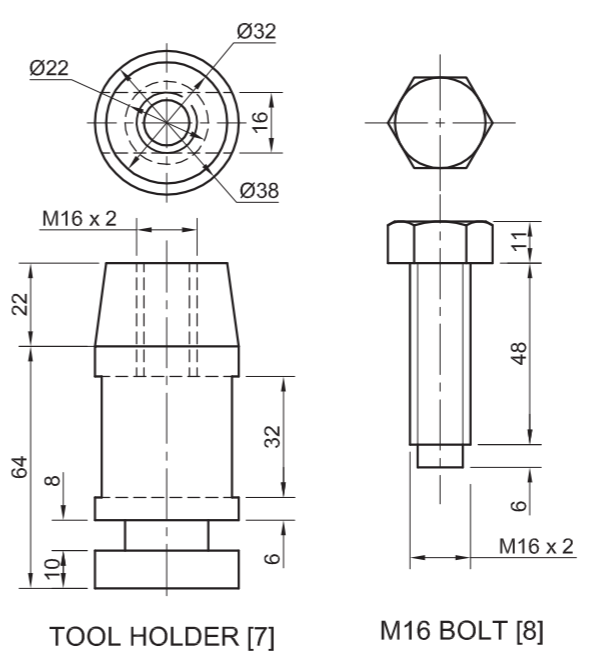
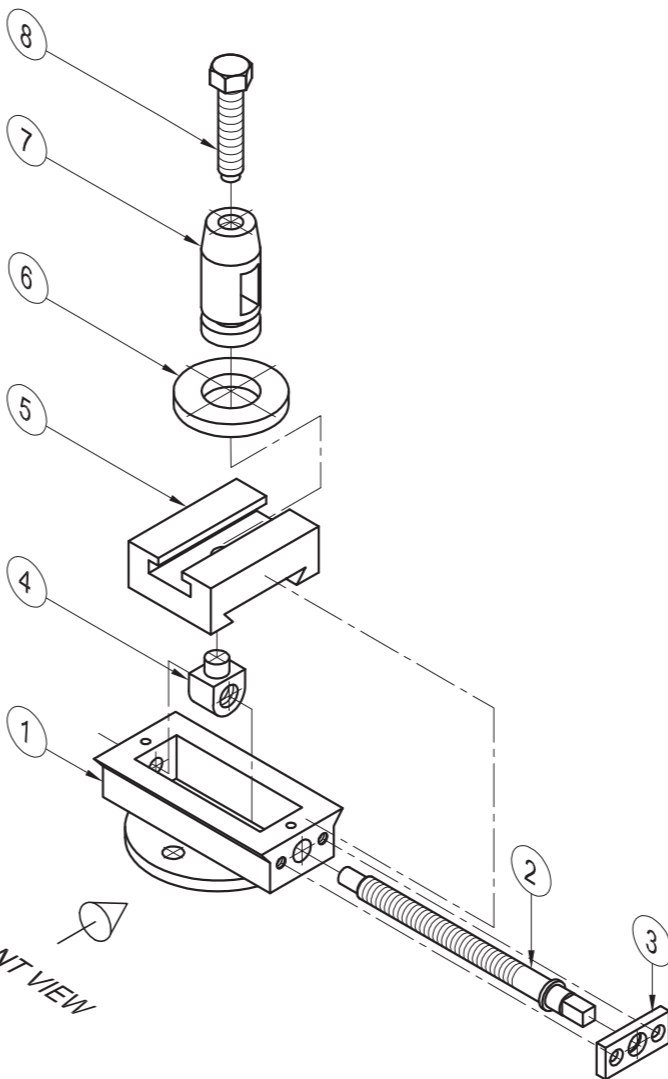
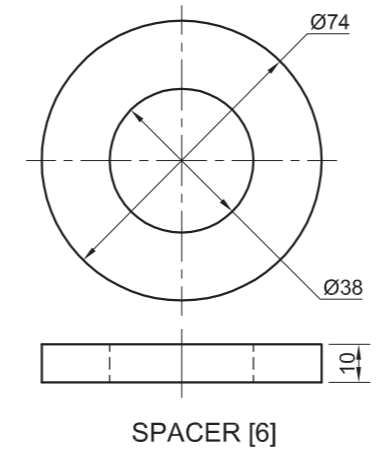
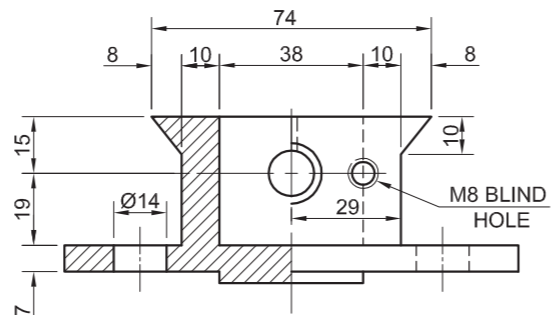
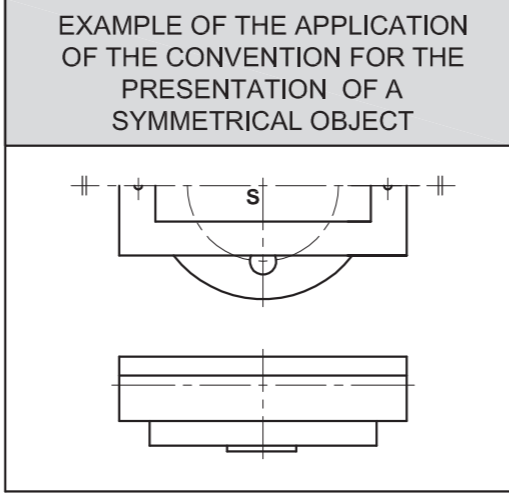
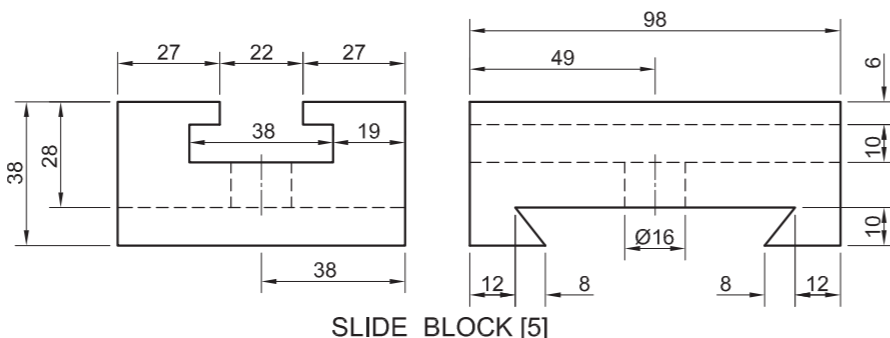
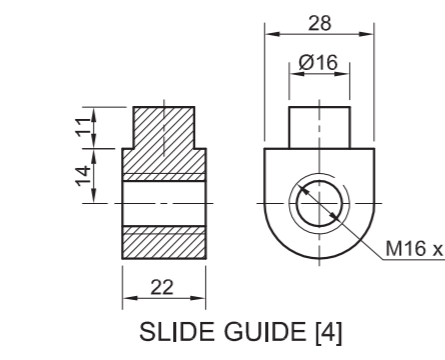
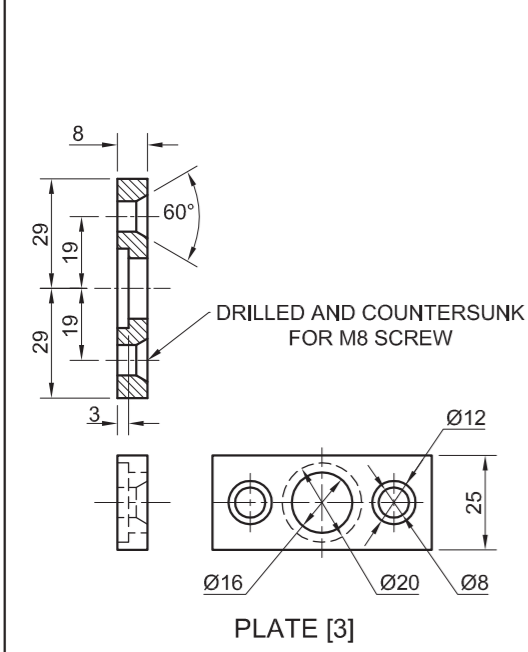
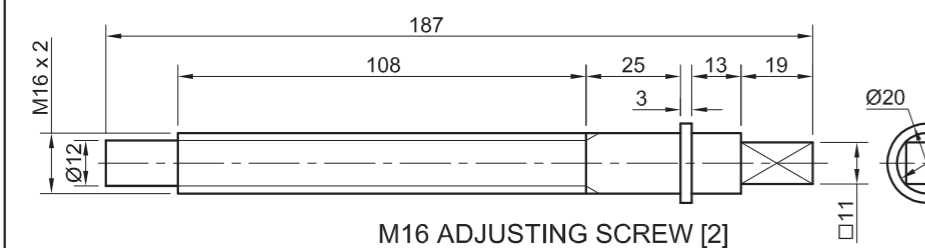
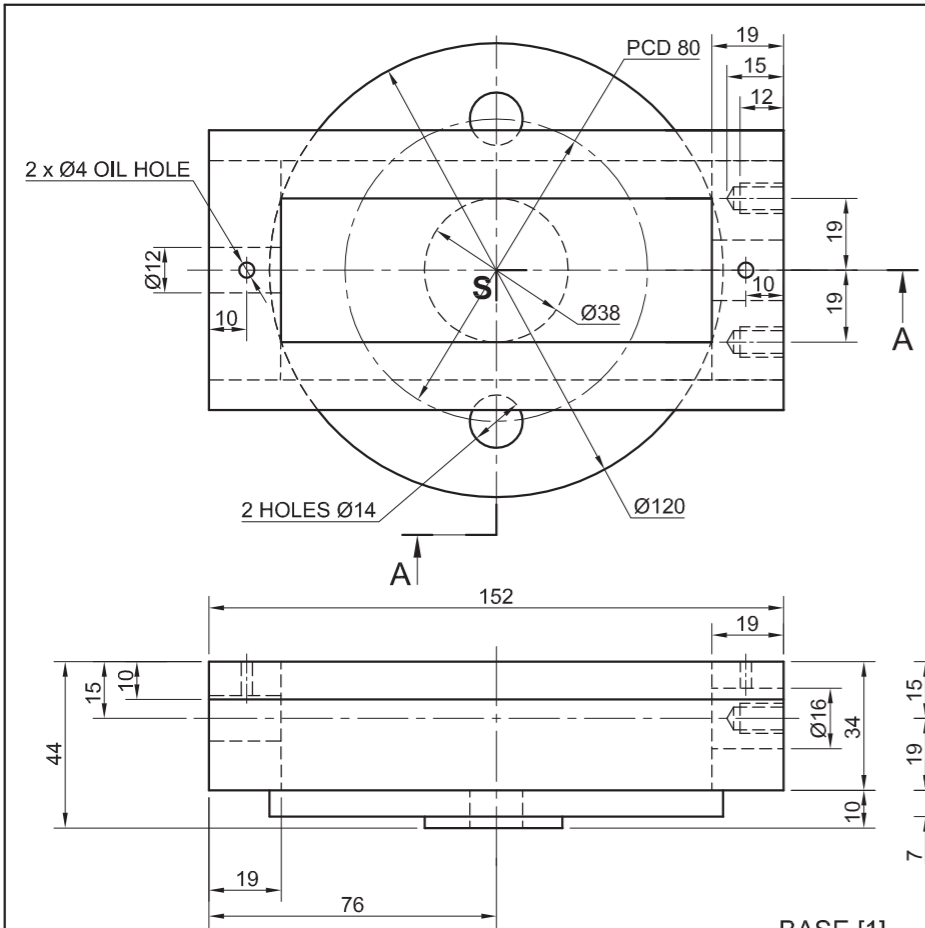

QUESTION 4: MECHANICAL ASSEMBLY

Given:

- Orthographic views of each of the parts of a tool holder assembly
- An example of the application of the convention for the drawing of a symmetrical object
- The exploded isometric drawing of the parts of the tool holder assembly, showing the position of each part relative to all the others
- The top view centre line and reference point **S** on page 6

Instructions:

- Answer this question on page 6.
- Using the given centre line and reference point **S**, draw, to scale 1 : 1 and in third-angle orthographic projection, the following views of the assembled parts of the tool holder assembly:
 - 4.1 A half sectional front view** on cutting plane A-A. Show the right side in section, as seen from the direction of the arrow shown on the exploded isometric drawing. The cutting plane is shown on the top view of the base (part 1).
 - 4.2 The top view.** Show **only the front half** of the top view by applying the convention for the presentation of a symmetrical object.

NOTE:

- Planning is essential.
- ALL drawings must comply with the guidelines as contained in the *SANS 10111*.
- Apply the convention of symmetry only to the top view.
- Show THREE faces of the M16 bolt (part 8) in the front view.
- In this drawing the M16 bolt (part 8) must be completely screwed into the tool holder (part 7).
- Add cutting plane A-A.
- NO hidden detail is required.

[88]

PARTS LIST			
	PARTS	QUANTITY	MATERIAL
1	BASE	1	CAST STEEL
2	M16 ADJUSTING SCREW	1	MILD STEEL
3	PLATE	1	MILD STEEL
4	SLIDE GUIDE	1	MILD STEEL
5	SLIDE BLOCK	1	CAST IRON
6	SPACER	1	MILD STEEL
7	TOOL HOLDER	1	MILD STEEL
8	M16 BOLT	1	MILD STEEL

BVJ
PROJECTS CC

13 BALLACK STREET
NEW GERMANY
www.bvjpro.co.za
031BMUNICH

TOOL HOLDER

ALL DIMENSIONS ARE IN MILLIMETRES.

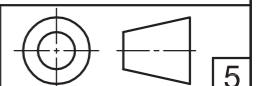



FOR OFFICIAL USE ONLY		
INCORRECT SCALE		
INCORRECT HATCHING		
PARTS NOT ASSEMBLED		
TOTAL		

ASSESSMENT CRITERIA					
TOP VIEW					
		POSSIBLE	OBTAINED	SIGN	MODERATED
1	BODY	5 1/2			
2	ADJUSTING SCREW	6			
3	PLATE	1			
4	SLIDE BLOCK	2 1/2			
5	SPACER	1/2			
6	TOOL HOLDER	1			
7	M16 BOLT	2 1/2			
SUBTOTAL		19			
SECTIONAL FRONT VIEW					
1	BODY	13			
2	ADJUSTING SCREW	10			
3	PLATE	3			
4	SLIDE GUIDE	3 1/2			
5	SLIDE BLOCK	4 1/2			
6	SPACER	3			
7	TOOL HOLDER	10			
8	M16 BOLT	8			
SUBTOTAL		55			
GENERAL					
1	CENTRE LINES	3			
2	CUTTING PLANE	4			
3	ASSEMBLY	7			
SUBTOTAL		14			
TOTAL		88			
PENALTIES (-)					
GRAND TOTAL					
EXAMINATION NUMBER					
EXAMINATION NUMBER					
6					



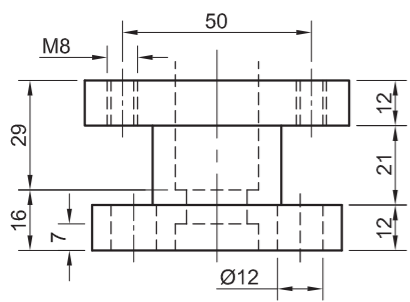
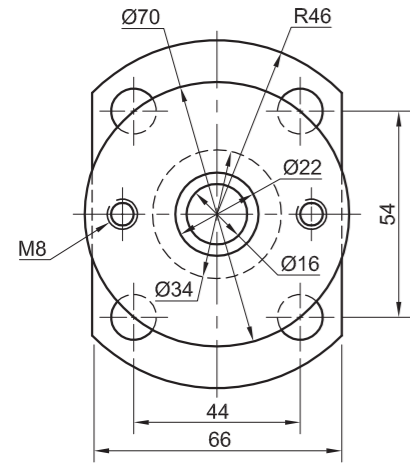

FILLER PIECE [2]

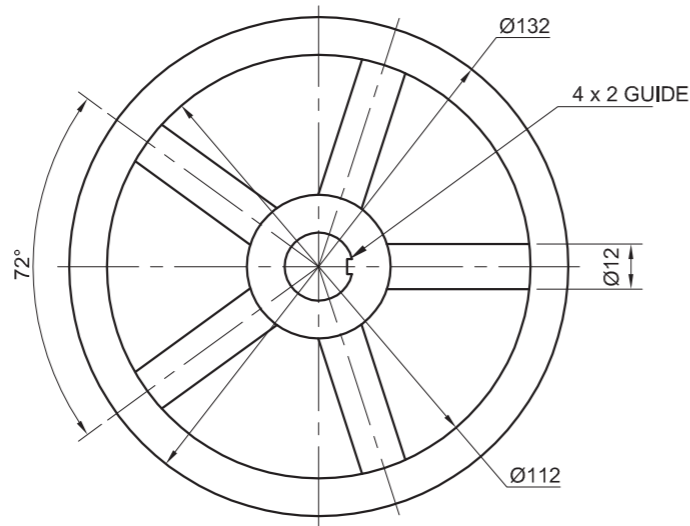

HAND WHEEL [4]

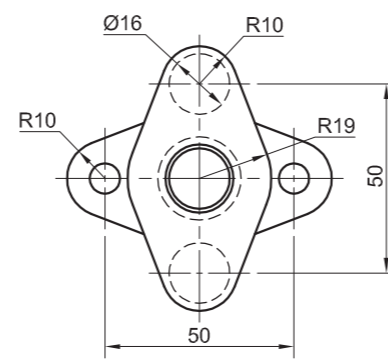

SPLIT PIECE [3]

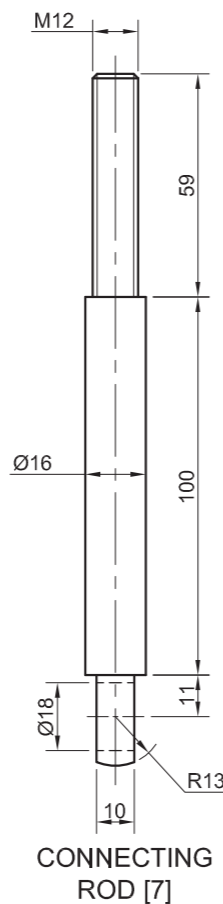
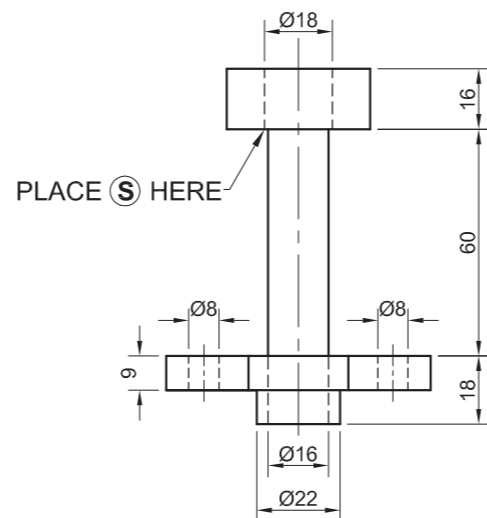

CONNECTING ROD [7]

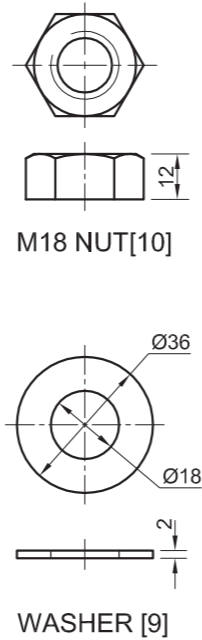

M18 NUT [10]

WASHER [9]

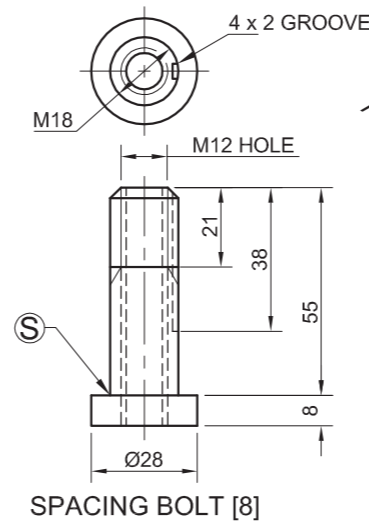

SPACING BOLT [8]

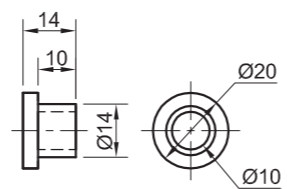

INNER VALVE CAP [5]

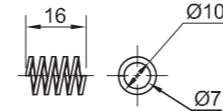

SPRING [6]

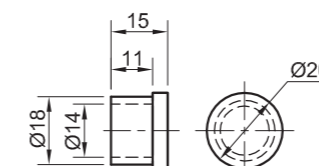

OUTER VALVE CAP [5]

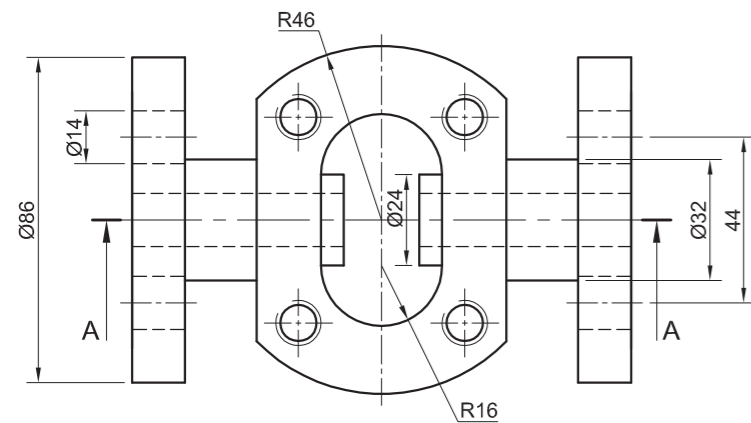

VALVE BASE [1]

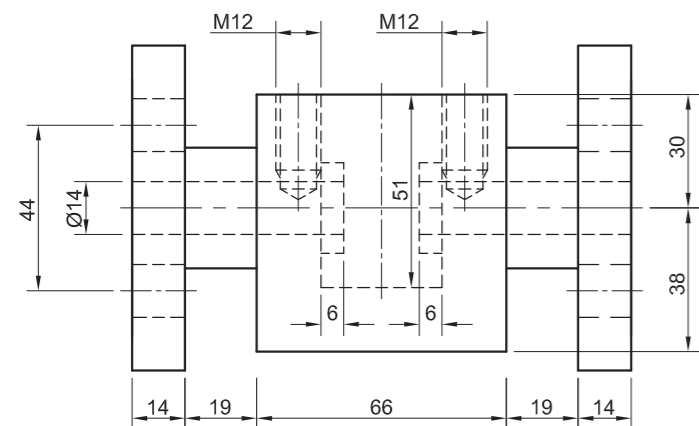

QUESTION 4: MECHANICAL ASSEMBLY

Given:

- The exploded isometric drawing of the parts of a steam valve assembly, showing the position of each part relative to all the others.
- Orthographic views of each of the parts of the steam valve assembly.

Instructions:

- Answer this question on page 6.
- Draw, to scale 1 : 1 and in third-angle orthographic projection, a **sectional front view** on cutting plane A-A, as seen from the direction of the arrow shown on the exploded isometric drawing. The cutting plane, which passes vertically through the centre of the assembly, is shown on the top view of the valve base (part 1).
- ALL drawings must comply with the guidelines as contained in the SANS 10111.

NOTE:

- Planning is essential.
- The M12 bolts (part 12) which connect the filler piece (part 2) to the valve base (part 1) are not shown and not required to be drawn.
- The M8 bolts (part 11) which connect the filler piece (part 2) to the split piece (part 3) are not shown and not required to be drawn.
- The spacing bolt (part 8) must be placed through the split piece (part 3) so that point S will be at the indicated position.
- Show THREE faces of the M18 nut.
- NO hidden detail is required.

[98]

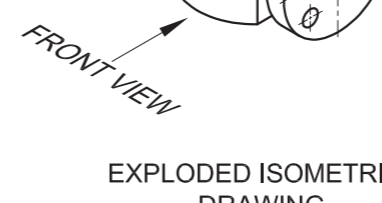

EXPLODED ISOMETRIC DRAWING

PARTS LIST

PARTS		QUANTITY	MATERIAL
1	VALVE BASE	1	CAST IRON
2	FILLER PIECE	1	CAST IRON
3	SPLIT PIECE	1	CAST IRON
4	HAND WHEEL	1	MILD STEEL
5	VALVE CAPS	2	STAINLESS STEEL
6	SPRING	1	SPRING STEEL
7	CONNECTING ROD	1	STAINLESS STEEL
8	SPACING BOLT	1	TOOL STEEL
9	WASHER	1	MILD STEEL
10	M18 NUT	1	MILD STEEL
11	M8 BOLT	2	MILD STEEL
12	M12 BOLT	4	MILD STEEL

WEST COAST
MANUFACTURING

17 MAIN ROAD
VELDDRIFT
7365
www.wce.co.za

TITLE

STEAM VALVE ASSEMBLY

ALL DIMENSIONS ARE IN MILLIMETRES.

ALL UNSPECIFIED RADII ARE R3.

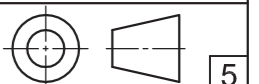



FOR OFFICIAL USE ONLY		
INCORRECT SCALE		
INCORRECT HATCHING		
PARTS NOT ASSEMBLED		
TOTAL PENALTIES (-)		

ASSESSMENT CRITERIA					
SECTIONAL FRONT VIEW					
		POSSIBLE	OBTAINED	SIGN	MODERATED
1	VALVE BASE	16 $\frac{1}{2}$			
2	VALVE CAPS	8 $\frac{1}{2}$			
3	SPRING	1 $\frac{1}{2}$			
4	CONNECTING ROD	8 $\frac{1}{2}$			
5	FILLER PIECE	15			
6	SPLIT PIECE	11			
7	SPACING BOLT	8			
8	HAND WHEEL	9			
9	WASHER	2			
10	M18 NUT	5			
SUBTOTAL		85			
GENERAL					
1	CENTRE LINES	3			
2	ASSEMBLY	10			
SUBTOTAL		13			
TOTAL		98			
TOTAL PENALTIES(-)					
GRAND TOTAL					
EXAMINATION NUMBER					
EXAMINATION NUMBER					
6					





FOR OFFICIAL USE ONLY		
NOT IN THIRD ANGLE		
INCORRECT OVERALL SCALE		
INCORRECT HATCHING		
PARTS NOT ASSEMBLED		
PARTS DRAWN FREEHAND		
TOTAL PENALTIES (-)		

ASSESSMENT CRITERIA					
TOP VIEW					
		POSSIBLE	OBTAINED	SIGN	MODERATED
1	WORM SCREW	3½			
2	LEVER	4			
3	END RING	3			
4	BEAM	4½			
5	STRONG ARM	10			
6	M8 BOLT	7			
SUBTOTAL		32			
SECTIONAL FRONT VIEW					
1	WORM SCREW	15			
2	LEVER	7			
3	END RING	3			
4	BEAM	5½			
5	STRONG ARM	10½			
6	M8 BOLT	9			
SUBTOTAL		50			
GENERAL					
1	CENTRE LINES	3			
2	ASSEMBLY	6			
3	CUTTING PLANE	5			
SUBTOTAL		14			
TOTAL		96			
TOTAL PENALTIES(-)					
GRAND TOTAL					
EXAMINATION NUMBER					
EXAMINATION NUMBER					
					6



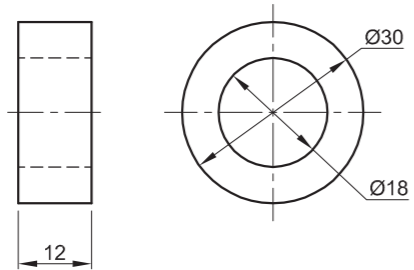

SEAL [2]

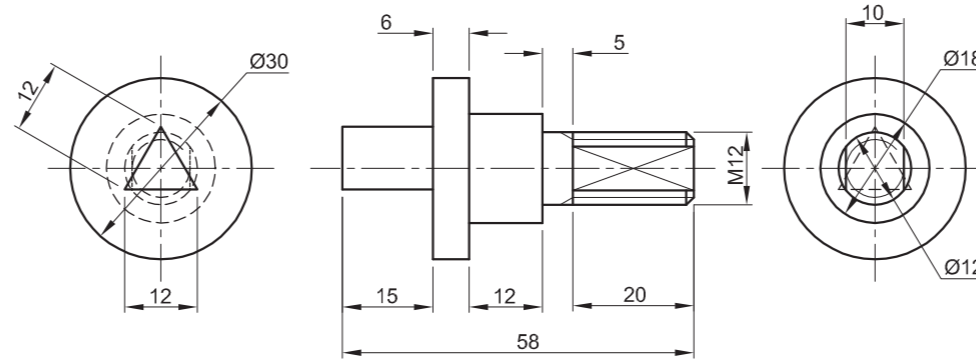

SHAFT [1]

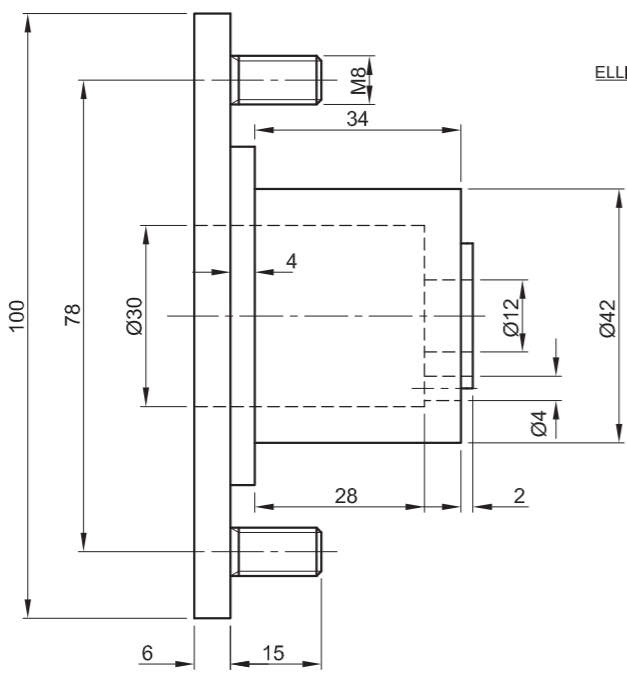

BASE [3]

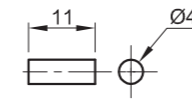
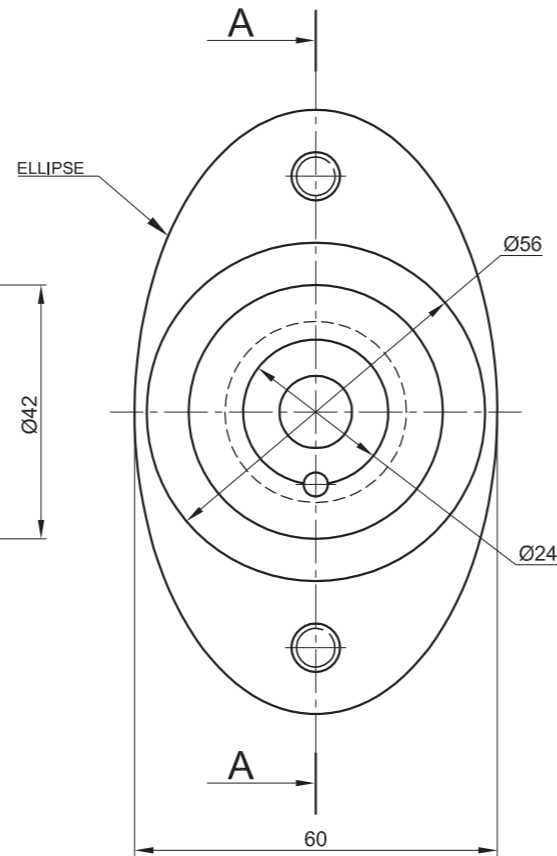

GUIDE PIN [4]

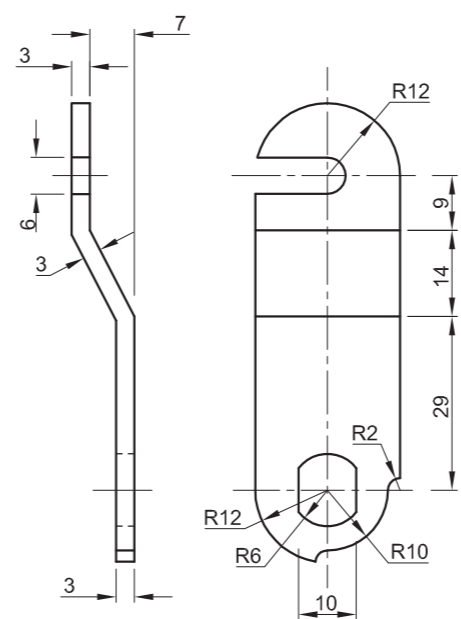

LOCKING LEVER [5]

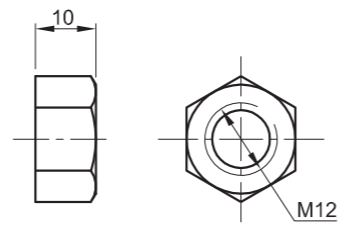

M12 NUT [7]

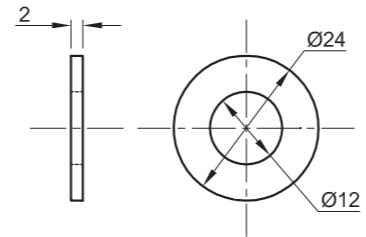

WASHER [6]

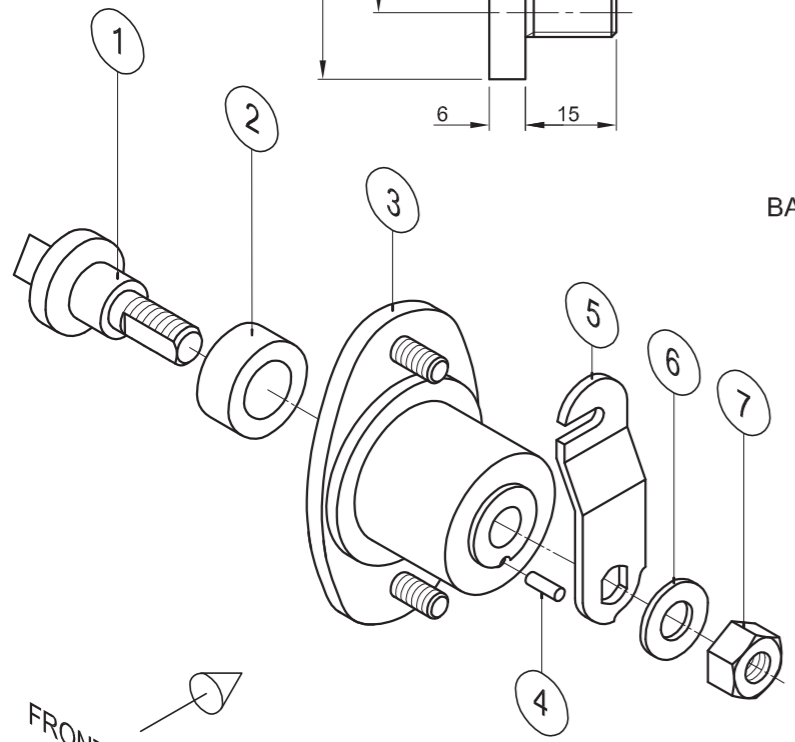

EXPLODED ISOMETRIC DRAWING

FRONT VIEW

QUESTION 4: MECHANICAL ASSEMBLY

Given:

- The exploded isometric drawing of the parts of a distribution box lock assembly, showing the position of each part relative to all the others
- Orthographic views of each of the parts of the distribution box lock assembly

Instructions:

- Answer this question on page 6.
- Draw, to scale 2 : 1 and in third-angle orthographic projection, the following views of the assembled parts of the distribution box lock assembly:

4.1 A sectional front view on cutting plane A-A, as seen from the direction of the arrow shown on the exploded isometric drawing. The cutting plane, which passes vertically through the centre of the assembly, is shown on the right view of the base (part 3).

4.2 The right view

- ALL drawing must comply with the guidelines contained in the SANS 10111.

NOTE:

- Show THREE faces and ALL necessary construction of the M12 nut.
- Show ALL necessary construction of the ellipse.
- Show ALL necessary construction of the triangle.
- Add cutting plane A-A to the drawing.
- NO hidden detail is required.

[94]

PARTS LIST		
PART	QUANTITY	MATERIAL
1	1	SHAFT STAINLESS STEEL
2	1	SEAL RUBBER
3	1	BASE CAST IRON
4	1	GUIDE PIN MILD STEEL
5	1	LOCKING LEVER MILD STEEL
6	1	WASHER MILD STEEL
7	1	M12 NUT MILD STEEL



JPW
ENGINEERING CC

123 STRUBEN STREET
PRETORIA
0001
www.jpwengineering.co.za
012 345 6789

DISTRIBUTION BOX LOCK

ALL DIMENSIONS ARE IN MILLIMETRES

ALL UNSPECIFIED RADII ARE R3.

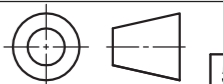

5





PENALTIES		
NOT IN THIRD ANGLE		
INCORRECT OVERALL SCALE		
INCORRECT HATCHING		
TOTAL PENALTIES (-)		

ASSESSMENT CRITERIA					
SECTIONAL FRONT VIEW					
		POSSIBLE	OBTAINED	SIGN	MODERATED
1	SHAFT	17 ½			
2	SEAL	2			
3	BASE	18 ½			
4	GUIDE PIN	2 ½			
5	LOCKING LEVER	7			
6	WASHER	2 ½			
7	M12 NUT	6 ½			
SUBTOTAL		56 ½			
RIGHT VIEW					
1	SHAFT	5			
2	M12 NUT	4			
3	WASHER	1			
4	LOCKING LEVER	4 ½			
5	BASE	9			
6	GUIDE PIN	1			
7	CUTTING PLANE	3			
SUBTOTAL		27 ½			
GENERAL					
1	CENTRE LINES	4			
2	ASSEMBLY	6			
SUBTOTAL		10			
TOTAL		94			
TOTAL PENALTIES (-)					
FINAL TOTAL					
EXAMINATION NUMBER					
EXAMINATION NUMBER				6	



STAPLE

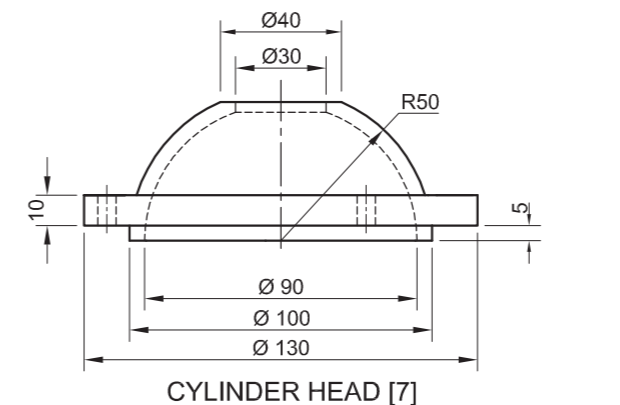
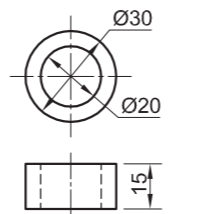
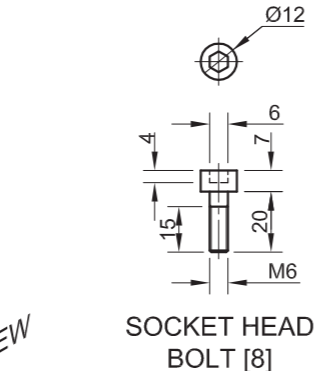
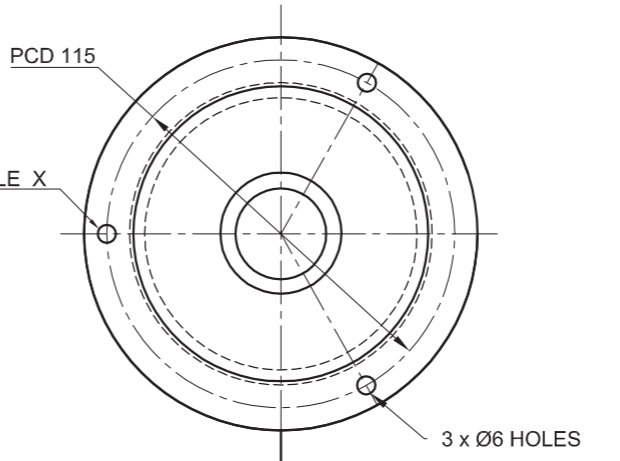
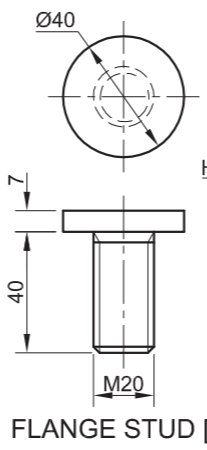
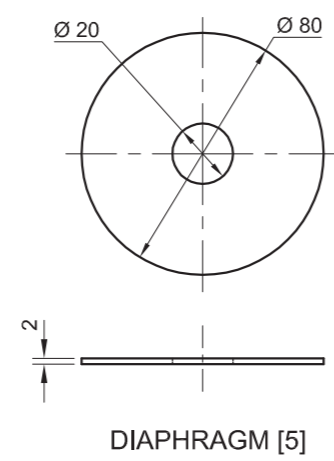
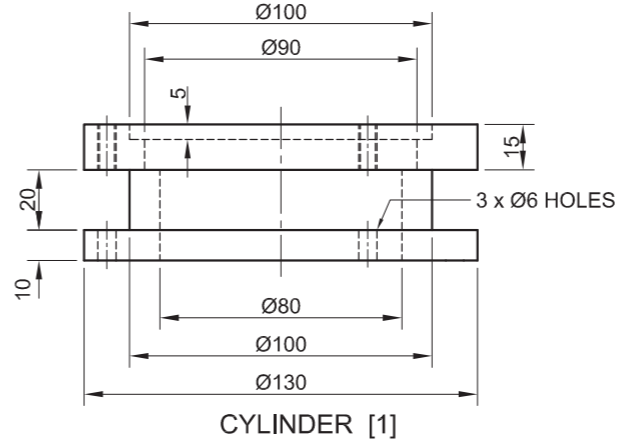
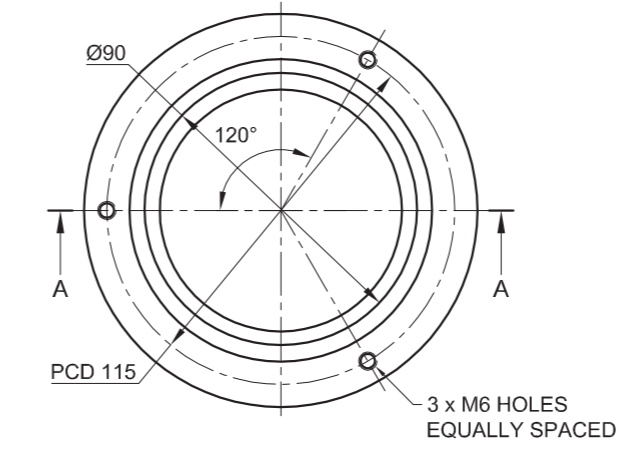
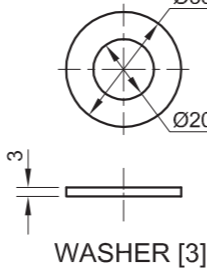
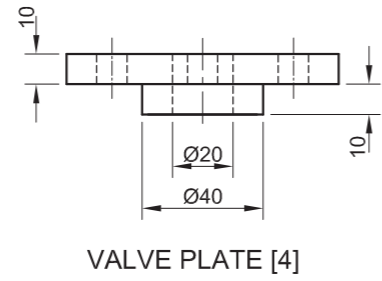
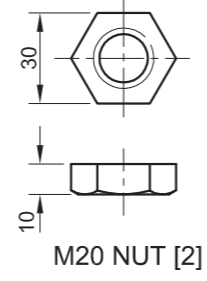
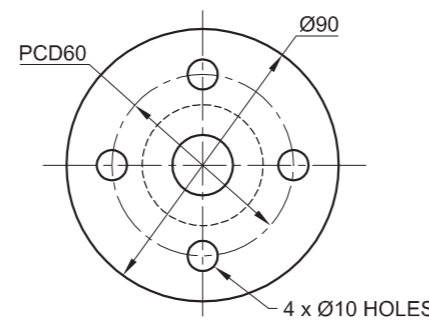
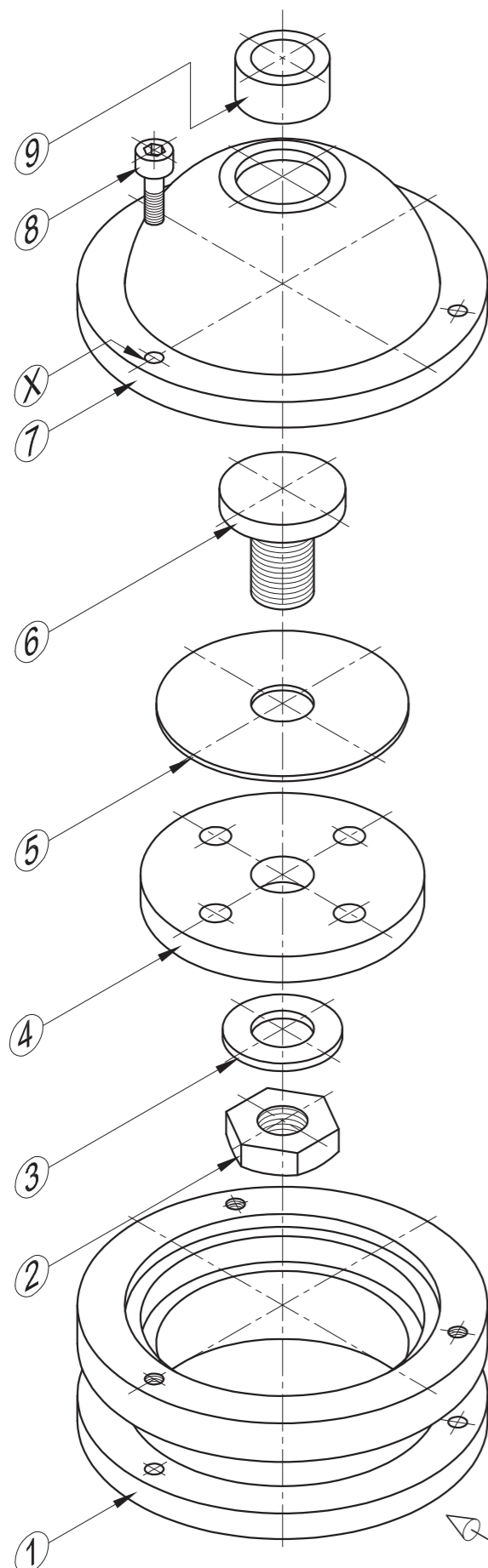
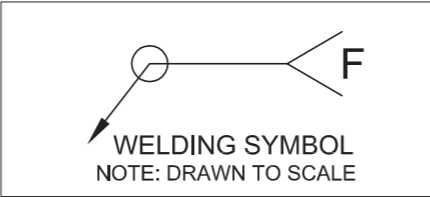

QUESTION 4: MECHANICAL ASSEMBLY

Given:

- The exploded isometric drawing of the parts of a one-way valve assembly, showing the position of each part relative to all the others
- Orthographic views of each of the parts of the one-way valve assembly

Instructions:

- Answer this question on page 6.
- Draw, to scale 1 : 1 and in third-angle orthographic projection, the following views of the assembled parts of the one-way valve assembly:
 - 4.1 A sectional front view** on cutting plane A-A, as seen from the direction of the arrow shown on the exploded isometric drawing. The cutting plane, which passes vertically through the centre of the assembly, is shown on the top view of the cylinder (part 1).
 - 4.2 The top view**
 - 4.3 The left view**
- ALL drawings must comply with the guidelines contained in the SANS 10111.

NOTE:

- Proper planning is essential.
- Draw only ONE socket head bolt in the hole marked X.
- The outlet pipe (part 9) fits into the cylinder head (part 7) and must be welded in place. Show the given welding symbol on the left view.
- Show THREE faces and ALL the necessary construction for the M20 nut.
- Show TWO faces of the inside of the socket head bolt.
- Add cutting plane A-A to the drawing.
- NO hidden detail is required.

[95]

PARTS LIST			
	PART	QUANTITY	MATERIAL
1	CYLINDER	1	CAST IRON
2	M20 NUT	1	STAINLESS STEEL
3	WASHER	1	STAINLESS STEEL
4	VALVE PLATE	1	CAST IRON
5	DIAPHRAGM	1	RUBBER
6	FLANGE STUD	1	STAINLESS STEEL
7	CYLINDER HEAD	1	CAST IRON
8	SOCKET HEAD BOLT	3	STAINLESS STEEL
9	OUTLET PIPE	1	STAINLESS STEEL

JPW ENGINEERING CC
 123 STRUBEN STREET
 PRETORIA 0001
 www.jpwengineering.co.za
 012 345 6789

ONE-WAY VALVE

ALL DIMENSIONS ARE IN MILLIMETRES. ALL UNSPECIFIED RADII ARE R4.

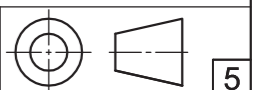

5





PENALTIES		
THIRD-ANGLE (TA)		
INCORRECT SCALE (IS)		
NUT CONSTRUCTION (NC)		
HATCHING (H)		
TOTAL		

Carry the TOTAL over to the penalties row under GENERAL.

ASSESSMENT CRITERIA					
SECTIONAL FRONT VIEW					
		POSSIBLE	OBTAINED	SIGN	MODERATED
1	CYLINDER	12			
2	M20 NUT	6			
3	WASHER	2			
4	VALVE PLATE	9 1/2			
5	DIAPHRAGM	2 1/2			
6	FLANGE STUD	6 1/2			
7	CYLINDER HEAD	9 1/2			
8	SOCKET HEAD BOLT	8			
9	OUTLET PIPE	4			
SUBTOTAL		60			
TOP VIEW					
1	CYLINDER HEAD	3 1/2			
2	SOCKET HEAD BOLT	1 1/2			
3	OUTLET PIPE	1			
SUBTOTAL		6			
LEFT VIEW					
1	CYLINDER	4			
2	CYLINDER HEAD	3			
3	SOCKET HEAD BOLT	1 1/2			
4	OUTLET PIPE	1 1/2			
5	WELDING SYMBOL	2			
6	CUTTING PLANE	3			
SUBTOTAL		15			
GENERAL					
1	CENTRE LINES	6			
2	ASSEMBLY	8			
SUBTOTAL		14			
PENALTIES (-)					
TOTAL		95			
EXAMINATION NUMBER					
				6	



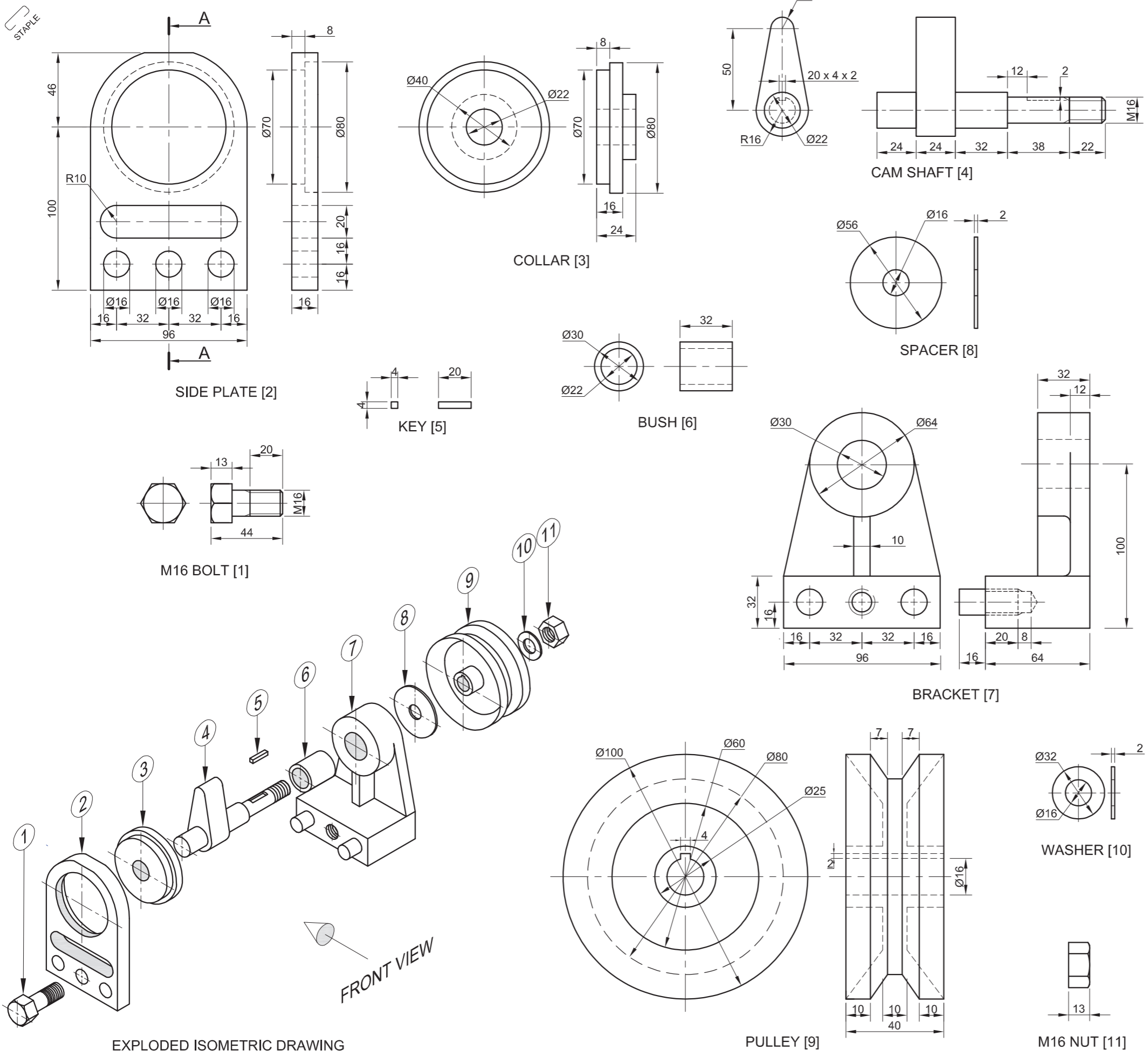

QUESTION 4: MECHANICAL ASSEMBLY

Given:

- The exploded isometric drawing of the parts of a cam-pulley assembly, showing the position of each part relative to all the others
- Orthographic views of each of the parts of the cam-pulley assembly

Instructions:

- Answer this question on page 6.
- Draw, to scale 1 : 1 and in third-angle orthographic projection, the following views of the assembled parts of the cam-pulley assembly:
 - 4.1 **A sectional front view** on cutting plane A-A, as seen from the direction of the arrow shown on the exploded isometric drawing. The cutting plane, which passes vertically through the centre of the assembly, is shown on the left view of the side plate (part 2).
 - 4.2 **The left view**
- ALL drawing must comply with the guidelines contained in the SANS 10111.

NOTE:

- Show THREE faces and ALL the necessary construction of the M16 nut in the front view.
- Show TWO faces and ALL the necessary construction of the M16 nut head in the front view.
- Insert cutting plane A-A.
- NO hidden detail is required.

[95]

PARTS LIST			
PART	QUANTITY	MATERIAL	
1. M16 BOLT	1	MILD STEEL	
2. SIDE PLATE	1	CAST IRON	
3. COLLAR	1	MILD STEEL	
4. CAM SHAFT	1	MILD STEEL	
5. KEY	1	BRASS	
6. BUSH	1	CAST IRON	
7. BRACKET	1	MILD STEEL	
8. SPACER	1	MILD STEEL	
9. PULLEY	1	CAST IRON	
10. WASHER	1	MILD STEEL	
11. M16 NUT	1	MILD STEEL	

 123 STRUBEN STREET
 PRETORIA
 0001
 www.jpwengineering.co.za
 012 345 6789

CAM-PULLEY

ALL DIMENSIONS ARE IN MILLIMETRES. ALL UNSPECIFIED RADII ARE R4

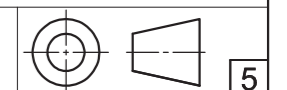



ASSESSMENT CRITERIA				
SECTIONAL FRONT VIEW				
1	BRACKET	7 $\frac{1}{2}$		
2	SIDE PLATE	4		
3	CAM SHAFT	10		
4	BELT PULLEY	13 $\frac{1}{2}$		
5	COLLAR	3 $\frac{1}{2}$		
6	M16 NUT	5		
7	M16 BOLT	8		
8	BUSH	2		
9	SPACER	1		
10	KEY	1 $\frac{1}{2}$		
11	WASHER	1		
H	HATCHING	13 $\frac{1}{2}$		
SUBTOTAL		70 $\frac{1}{2}$		
LEFT VIEW				
1	SIDE PLATE	5		
2	BRACKET	2		
3	COLLAR	$\frac{1}{2}$		
4	BOLT	1		
5	CAM SHAFT	2		
6	PULLEY	1		
SUBTOTAL		11 $\frac{1}{2}$		
GENERAL				
1	CENTRE LINES	8		
2	ASSEMBLY	5		
SUBTOTAL		13		
PENALTIES (+)				
TOTAL		95		
EXAMINATION NUMBER				
EXAMINATION NUMBER				
				6

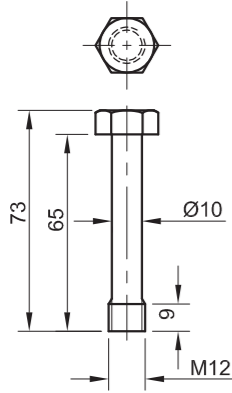

M12 BOLT [1]

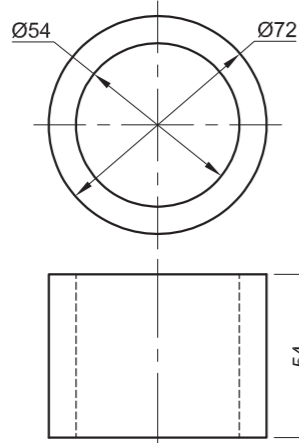

CYLINDER [4]

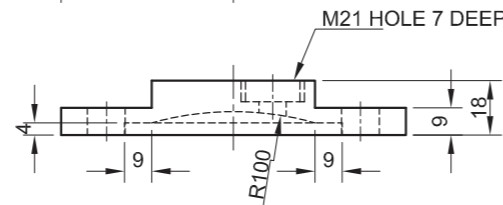
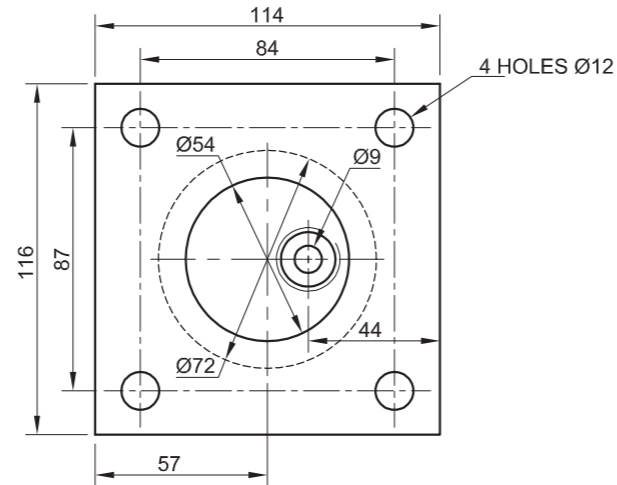

CYLINDER HEAD [3]

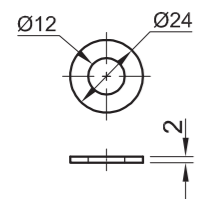

WASHER [2]

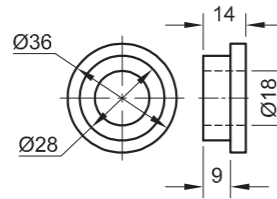

BUSH [6]

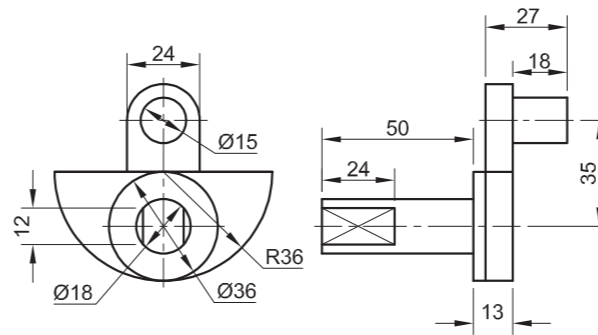

CRANK SHAFT [7]

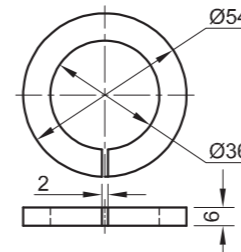

PISTON RING [8]

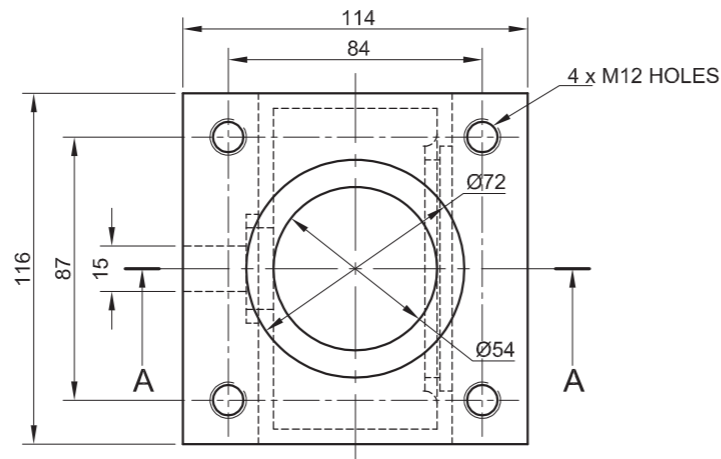

CRANK CASE [5]

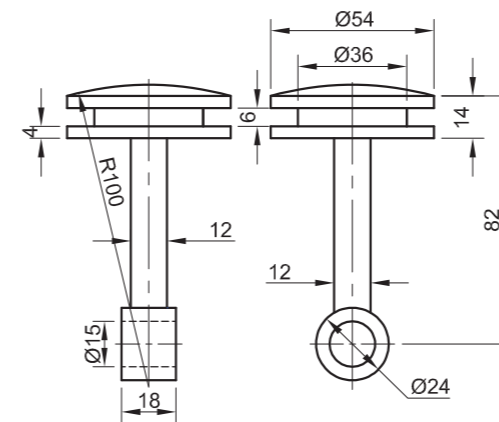

PISTON [9]

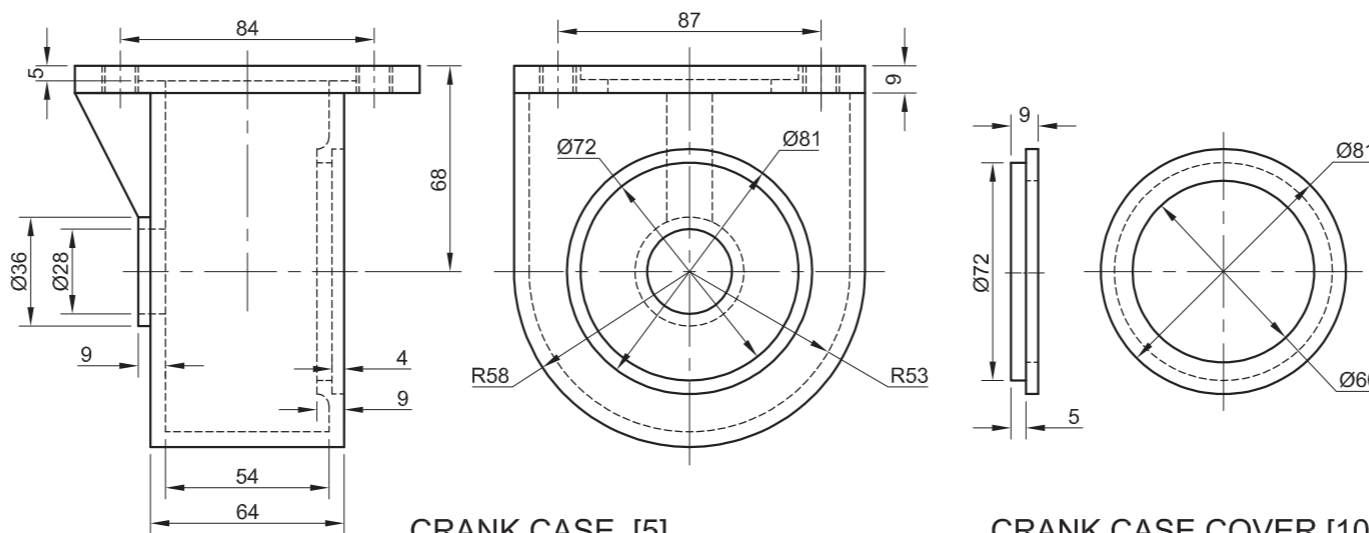

CRANK CASE COVER [10]

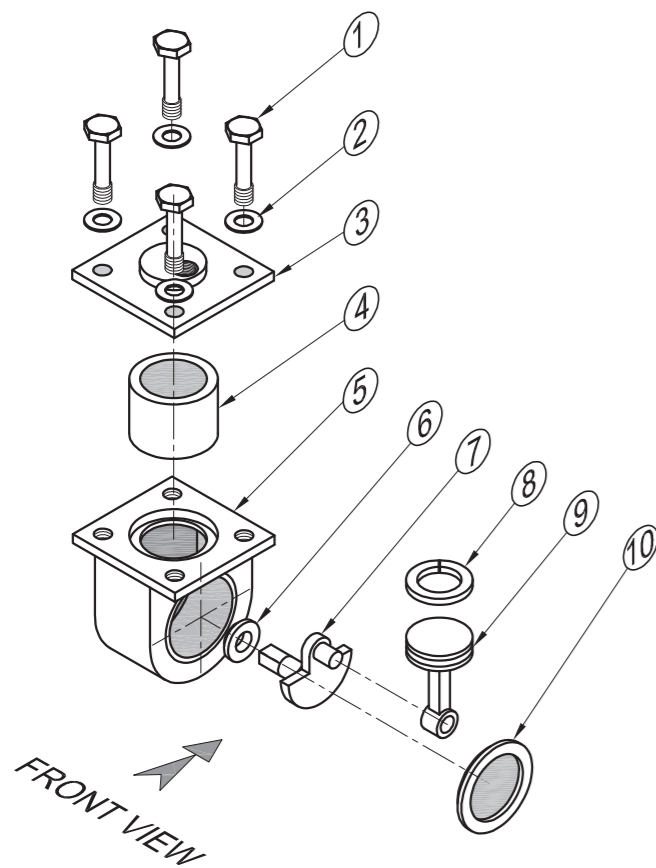

EXPLODED ISOMETRIC DRAWING

QUESTION 4: MECHANICAL ASSEMBLY

Given:

- The exploded isometric drawing of the parts of an air pump assembly, showing the position of each part relative to all the others
- Orthographic views of each of the parts of the air pump assembly

Instructions:

- Answer this question on page 6.
- Draw, to scale 1 : 1 and in third-angle orthographic projection, the following view of the assembled parts of the air pump assembly:
A sectional front view on cutting plane A-A, as seen from the direction of the arrow shown on the exploded isometric drawing. The cutting plane, which passes through the vertical centre of the assembly, is shown on the top view of the crank case (part 5).
- ALL drawings must comply with the guidelines contained in the SANS 10111.

NOTE:

- Show THREE faces of the M12 bolt on the left of the assembly.
- Show TWO faces of the M12 bolt on the right of the assembly.
- Show ALL necessary construction for the bolts. NO stencils may be used.
- NO hidden detail is required.

[93]

PARTS LIST		
PART	QUANTITY	MATERIAL
1. BOLT	4	HARDENED STEEL
2. WASHER	4	MILD STEEL
3. CYLINDER HEAD	1	CAST IRON
4. CYLINDER	1	HARDENED STEEL
5. CRANK CASE	1	CAST IRON
6. BUSH	1	BRONZE
7. CRANK SHAFT	1	HARDENED STEEL
8. PISTON RING	1	HARDENED STEEL
9. PISTON	1	ALUMINIUM
10. CRANK CASE COVER	1	MILD STEEL

TITLE

AIR PUMP

DYNAMIC
ENGINEERING

1051 BRAKEN ROAD
LITTLE FALLS
GAUTENG
1735
011 355 1550

ALL DIMENSIONS ARE IN MILLIMETRES. ALL UNSPECIFIED RADII ARE R4.





ASSESSMENT CRITERIA					
SECTIONAL FRONT VIEW					
		POSSIBLE	OBTAINED	SIGN	MODERATED
1	M12 BOLT + WASHER	15			
2	CYLINDER HEAD	9			
3	CYLINDER	5			
4	CRANK CASE	13			
5	BUSH	3			
6	CRANK SHAFT	9			
7	PISTON RING	1			
8	PISTON	6			
9	CRANK CASE COVER	5			
H	HATCHING	15			
SUBTOTAL		81			
GENERAL					
1	CENTRE LINES	3			
2	ASSEMBLY	9			
SUBTOTAL		12			
TOTAL		93			
EXAMINATION NUMBER					
EXAMINATION NUMBER				6	



QUESTION 4: MECHANICAL ASSEMBLY

Given:

- The exploded isometric drawing of the parts of a pulley assembly, showing the position of each part relative to all the others
- Orthographic views of each of the parts of the pulley assembly

Instructions:

- Answer this question on page 6.
- Draw, to scale 1 : 1 and in third-angle orthographic projection, the following views of the assembled parts of the pulley assembly:

4.1 A sectional front view on cutting plane A-A, as seen from the direction of the arrow shown on the exploded isometric drawing. The cutting plane, which passes through the vertical centre line of the assembly, is shown on the right view of the bracket (part 5).

4.2 The right view

- ALL drawings must comply with the guidelines contained in the SANS 10111.

NOTE:

- Show THREE faces of the M24 nut and ALL necessary construction. You may not use a stencil.
- NO hidden detail is required.

Add the following features to the drawing:

- The cutting plane A-A
- Label the sectional view SECTION A-A.

[95]

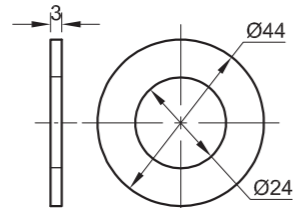
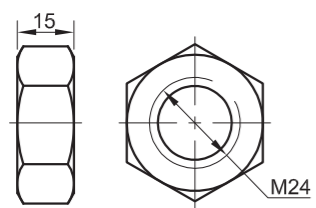
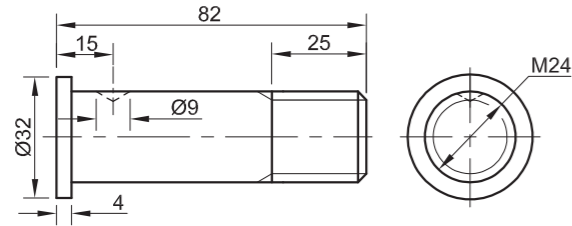
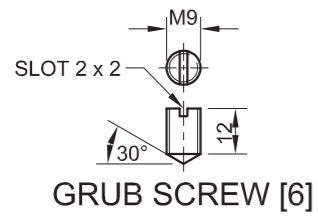

M24 NUT [1]

WASHER [2]

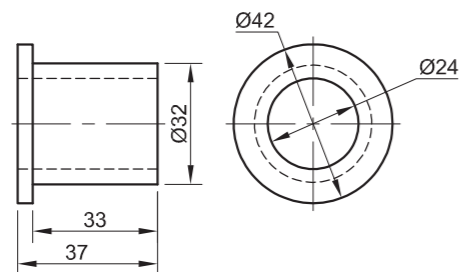

BUSH [4]

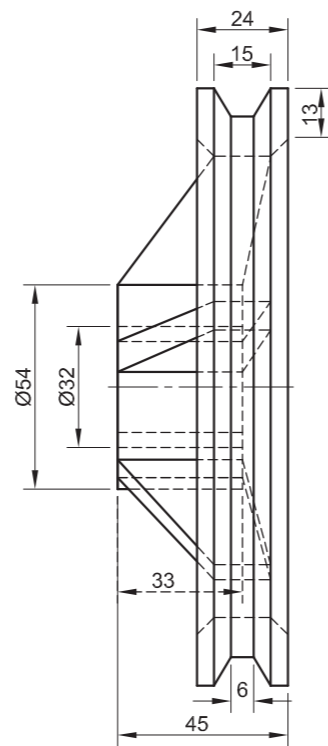

PULLEY [3]

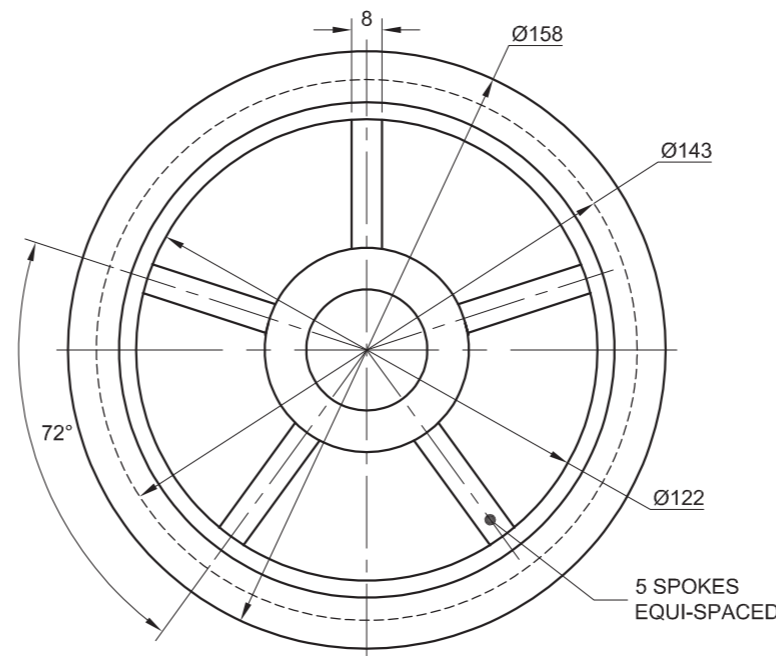

BRACKET [5]

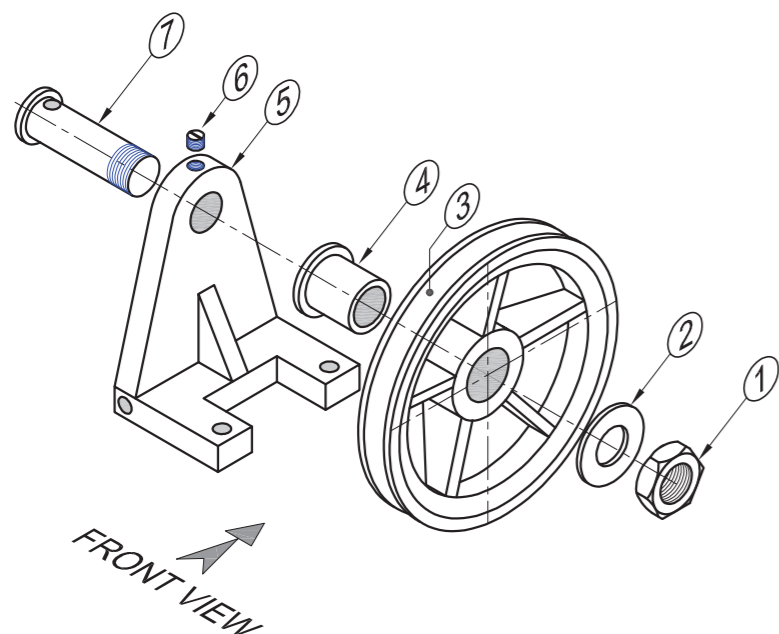

EXPLODED ISOMETRIC DRAWING

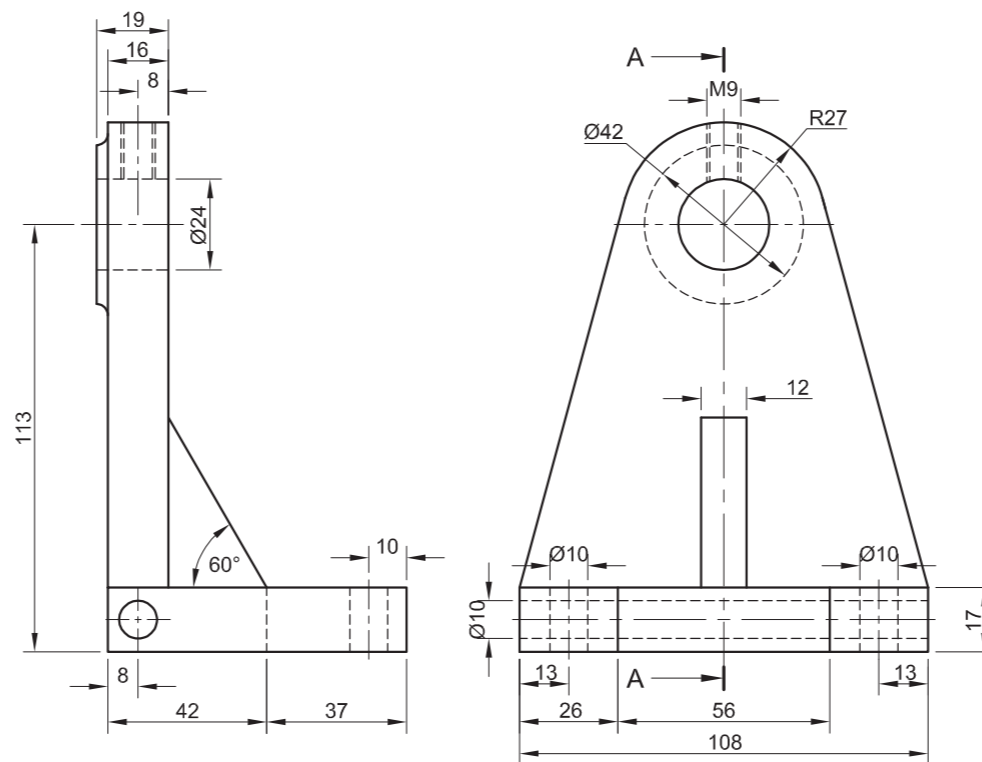

PARTS LIST		
PART	QUANTITY	MATERIAL
1. M24 NUT	1	MILD STEEL
2. WASHER	1	MILD STEEL
3. PULLEY	1	CAST IRON
4. BUSH	1	BRONZE
5. BRACKET	1	CAST IRON
6. GRUB SCREW	1	MILD STEEL
7. SHAFT	1	MILD STEEL

TITLE **PULLEY ASSEMBLY**

PRECISION ENGINEERING

54 SONTSEU ROAD
KINGSMEAD
DURBAN
4000
031 335 1600

ALL DIMENSIONS ARE IN MILLIMETRES. ALL UNSPECIFIED RADII ARE R3.



ASSESSMENT CRITERIA					
SECTIONAL FRONT VIEW					
		POSSIBLE	OBTAINED	SIGN	MODERATED
1	M24 NUT + WASHER	8½			
2	PULLEY	16			
3	BRACKET	9½			
4	BUSH	3			
5	GRUB SCREW	3			
6	SHAFT	7			
7	HATCHING	10			
SUBTOTAL		57			
RIGHT VIEW					
1	M24 NUT + WASHER	6			
2	PULLEY	8			
3	BRACKET	7½			
SUBTOTAL		21½			
GENERAL					
1	CENTRE LINES	7			
2	CUTTING PLANE + LABEL	3½			
3	ASSEMBLY	6			
SUBTOTAL		16½			
TOTAL		95			
EXAMINATION NUMBER					
EXAMINATION NUMBER				6	



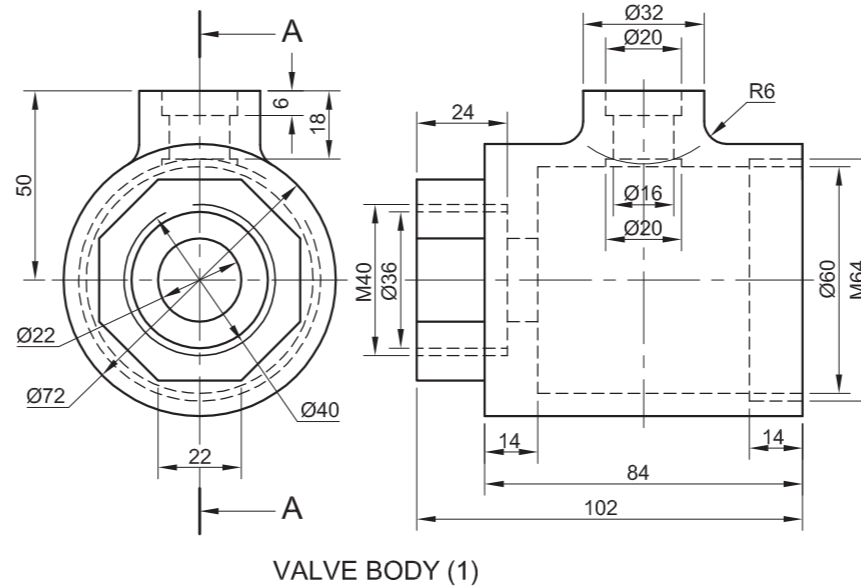
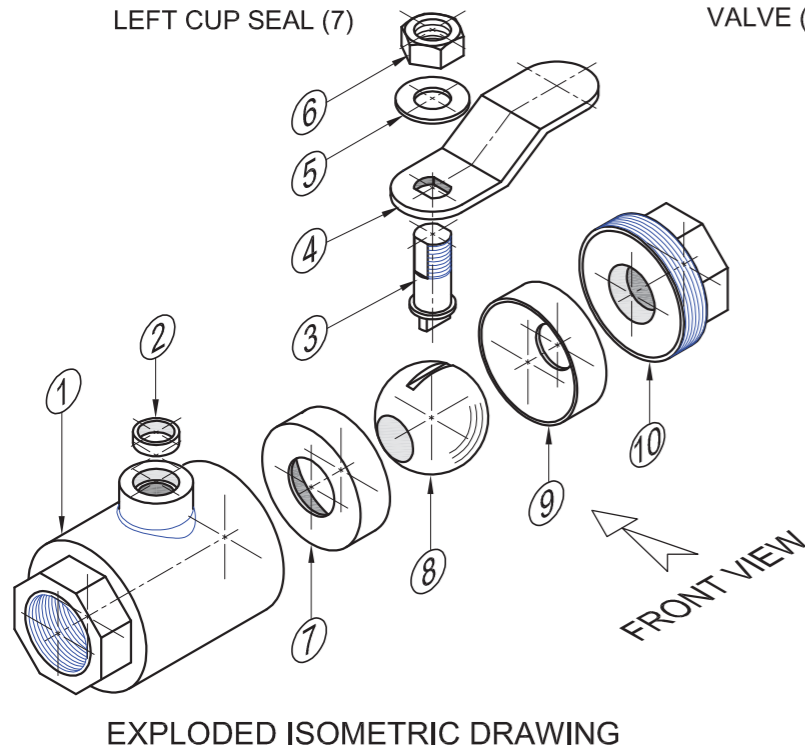
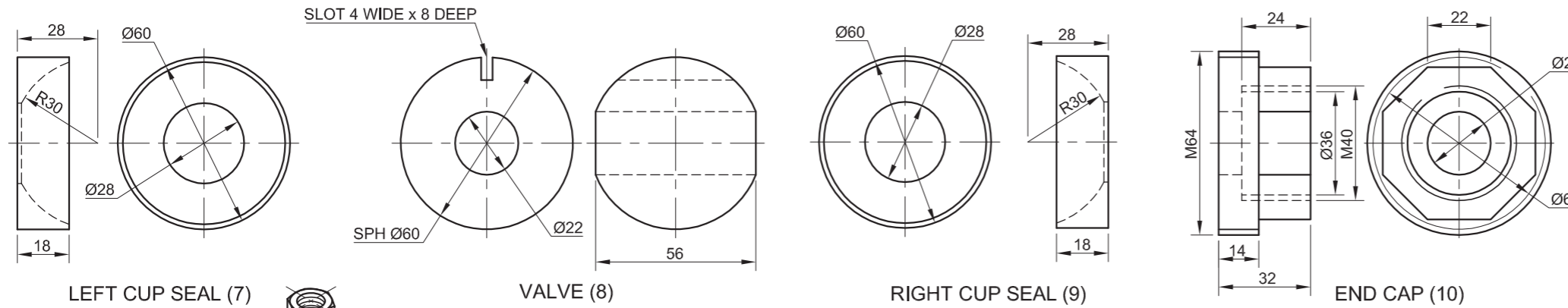
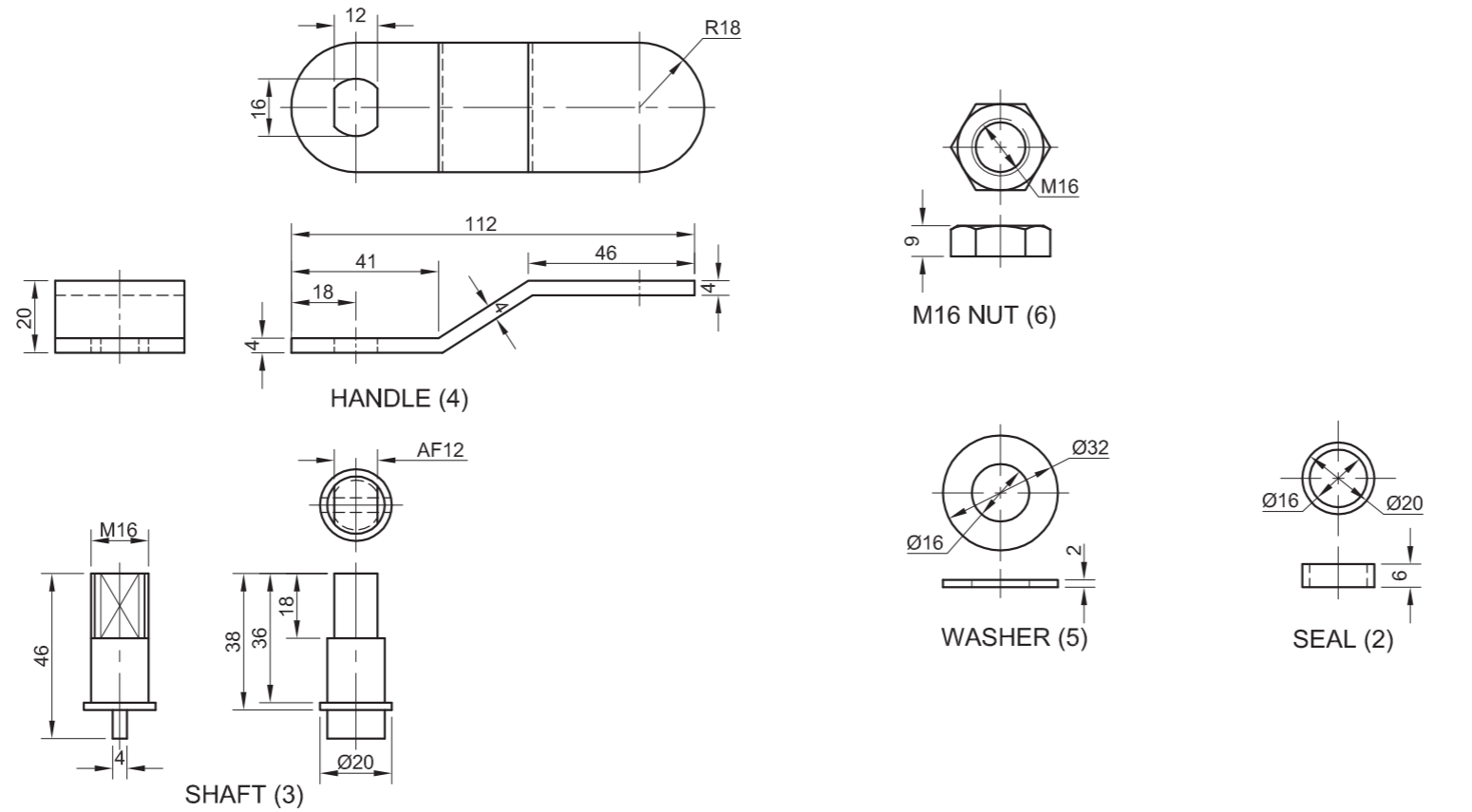

QUESTION 4: MECHANICAL ASSEMBLY

Given:

- The exploded isometric drawing of the parts of a stop valve assembly, showing the position of each part relative to all the others
- Orthographic views of each of the parts of the stop valve assembly

Instructions:

- Answer this question on page 6.
- Draw, to scale 1 : 1 and in third-angle orthographic projection, the following views of the assembled parts of the stop valve assembly:
 - 4.1 A sectional front view** on cutting plane A-A, as seen from the direction of the arrow shown on the exploded isometric drawing. The cutting plane, which passes vertically through the centre of the assembly, is shown on the left view of the valve body (part 1).
 - 4.2 The left view**
- ALL drawing must comply with the guidelines contained in the SABS 0111.

NOTE:

- Show THREE faces of the nut in the front view and ALL necessary construction.
- NO hidden detail is required.

[93]

PARTS LIST		
PART	QUANTITY	MATERIAL
1. VALVE BODY	1	CAST IRON
2. SEAL	1	FIBRE
3. SHAFT	1	MILD STEEL
4. HANDLE	1	STEEL
5. WASHER	1	MILD STEEL
6. M16 NUT	1	MILD STEEL
7. LEFT CUP SEAL	1	TEFLON
8. VALVE	1	STEEL
9. RIGHT CUP SEAL	1	TEFLON
10. END CAP	1	MILD STEEL

PRECISION ENGINEERING WORKS
 15 DYER STREET EAST LONDON
 www.precision.co.za
 043 645 7820

STOP VALVE

ALL DIMENSIONS ARE IN MILLIMETRES.

ALL UNSPECIFIED RADII ARE R2.

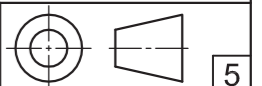



ASSESSMENT CRITERIA				
SECTIONAL FRONT VIEW				
1	VALVE BODY	10		
2	SEAL	2		
3	SHAFT	6		
4	HANDLE	5		
5	WASHER	2		
6	M16 NUT	5		
7	LEFT CUP SEAL	5		
8	VALVE	3		
9	RIGHT CUP SEAL	4		
10	END CAP	7		
H	HATCHING	13		
SUBTOTAL		62		
LEFT VIEW				
1	HANDLE	2½		
2	M16 NUT	4		
3	SHAFT	3		
4	WASHER	1½		
5	VALVE BODY	9		
SUBTOTAL		20		
GENERAL				
1	CENTRE LINES	2		
2	ASSEMBLY	9		
SUBTOTAL		11		
TOTAL		93		
EXAMINATION NUMBER				
EXAMINATION NUMBER				6



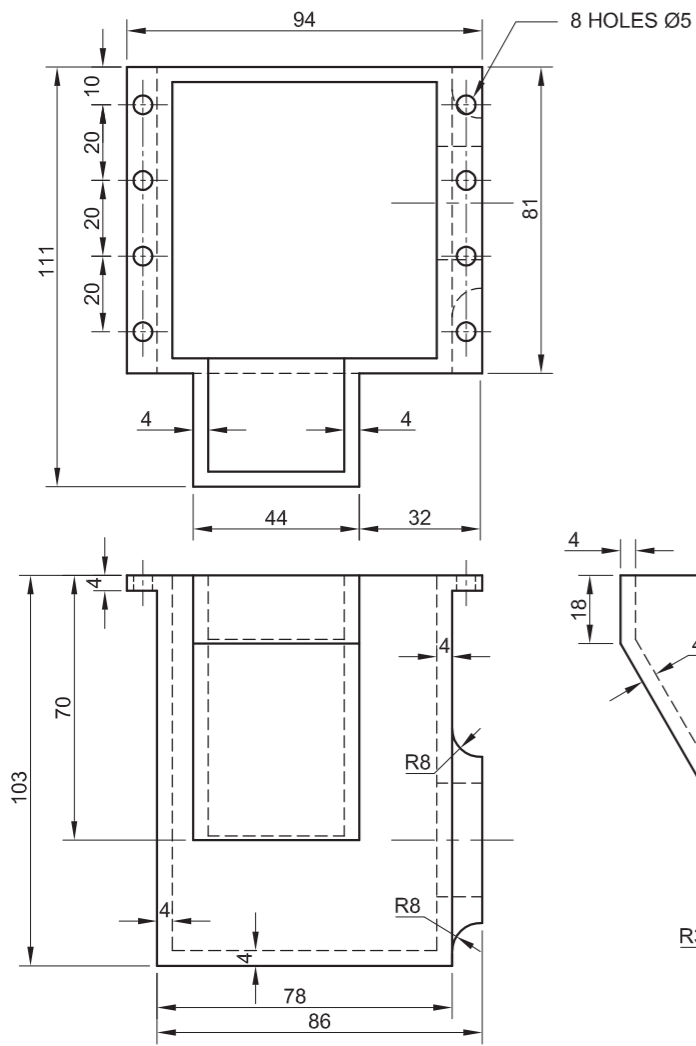

HOUSING (1)

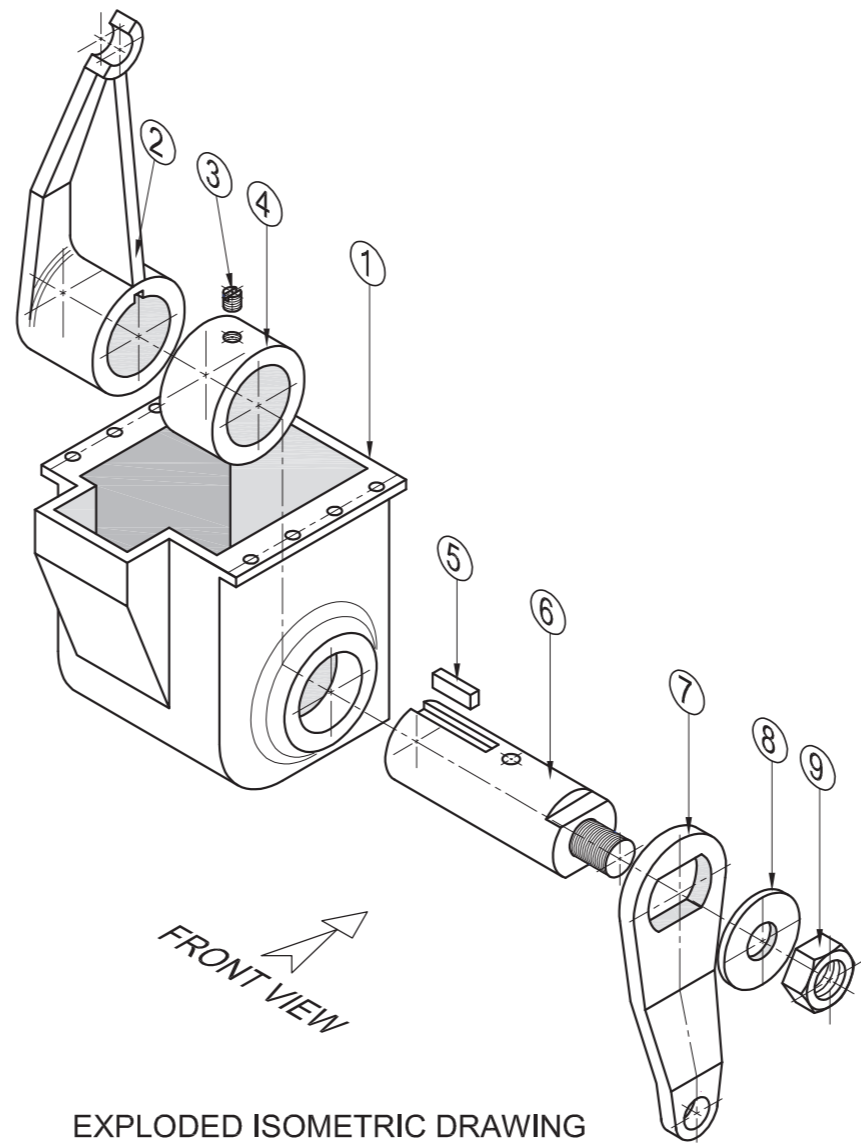

EXPLODED ISOMETRIC DRAWING

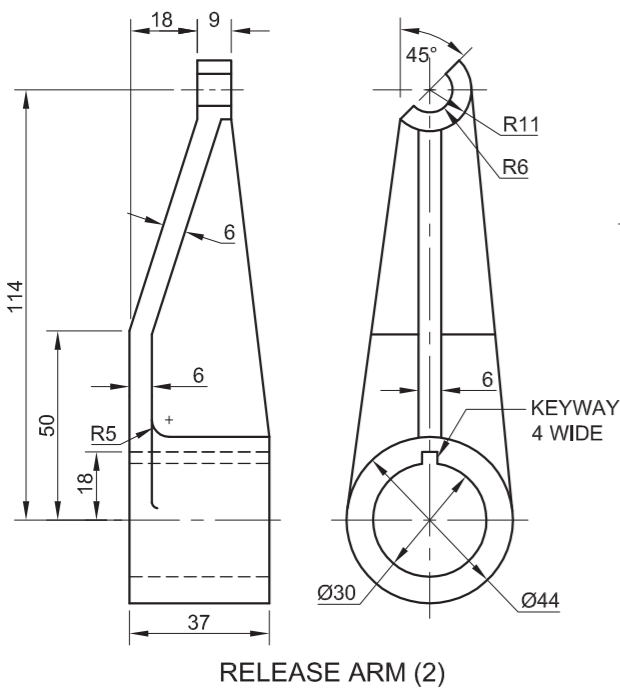

RELEASE ARM (2)

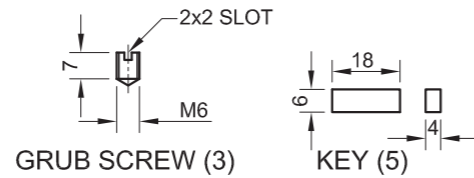

GRUB SCREW (3)

KEY (5)

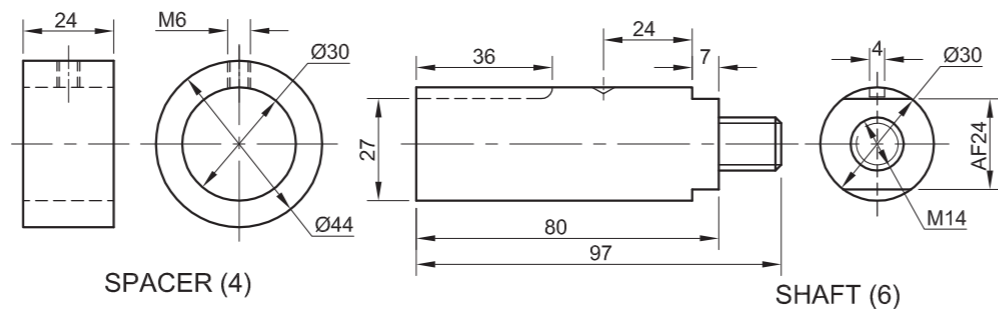

SPACER (4)

SHAFT (6)

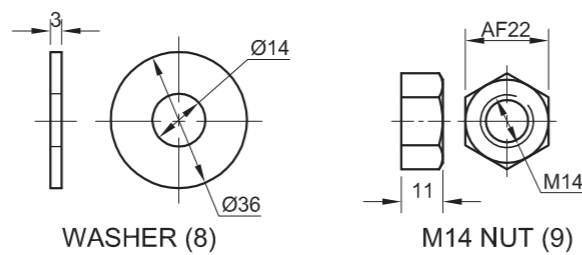

WASHER (8)

M14 NUT (9)

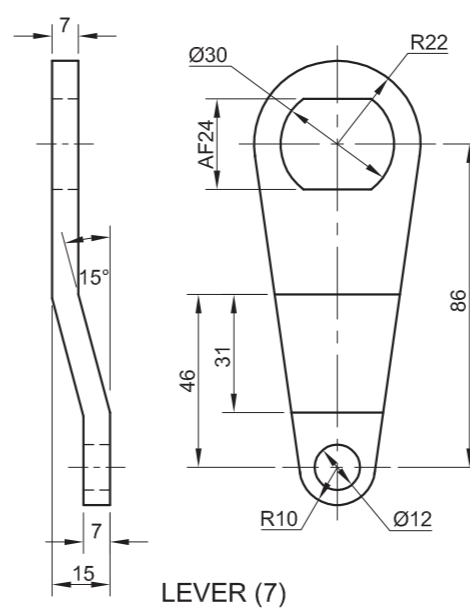

LEVER (7)

QUESTION 4: MECHANICAL ASSEMBLY

Given:

- The exploded isometric drawing of the parts of a clutch release housing assembly, showing the position of each part relative to all the others
- Orthographic views of each of the parts of the clutch release housing assembly

Instructions:

- Answer this question on page 6.
- Draw, to scale 1:1 and in third-angle orthographic projection, the following views of the assembled parts of the clutch release housing assembly:
 - 4.1 A sectional front view on cutting plane A-A, as seen from the direction of the arrow shown on the exploded isometric drawing. The cutting plane, which passes vertically through the centre of the assembly, is shown on the right view of the housing (part 1).
 - 4.2 The right view

NOTE:

- Show THREE faces of the nut in the front view and ALL necessary construction.
- NO hidden detail is required.

Add the following feature to the drawing:

- The cutting plane A-A

[92]

PARTS LIST		
PART	QUANTITY	MATERIAL
1. HOUSING	1	CAST IRON
2. RELEASE ARM	1	CAST IRON
3. GRUB SCREW	1	MILD STEEL
4. SPACER	1	MILD STEEL
5. KEY	1	MILD STEEL
6. SHAFT	1	MILD STEEL
7. LEVER	1	MILD STEEL
8. WASHER	1	MILD STEEL
9. M14 NUT	1	MILD STEEL

MASTERCAST ENGINEERING
 29 BURMAN ROAD
 DEALPARTY
 PORT ELIZABETH 6025
 www.mtech.co.za
 041 545 7820

CLUTCH RELEASE HOUSING

ALL DIMENSIONS ARE IN MILLIMETRES.

ALL UNSPECIFIED RADII ARE R2.

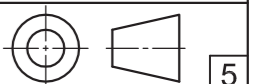



ASSESSMENT CRITERIA				
SECTIONAL FRONT VIEW				
1	HOUSING	9		
2	RELEASE ARM	9½		
3	GRUB SCREW	3		
4	SPACER	3		
5	KEY	2		
6	SHAFT	6½		
7	LEVER	7		
8	WASHER	2		
9	M14 NUT	5		
H	HATCHING	13		
SUBTOTAL		60		
RIGHT VIEW				
1	HOUSING	5		
2	RELEASE ARM	4		
3	LEVER	4		
4	WASHER + M14 NUT	4		
SUBTOTAL		17		
GENERAL				
1	CENTRE LINES	4		
2	CUTTING PLANE	3		
3	ASSEMBLY	8		
SUBTOTAL		15		
TOTAL		92		
EXAMINATION NUMBER				
EXAMINATION NUMBER				
				6



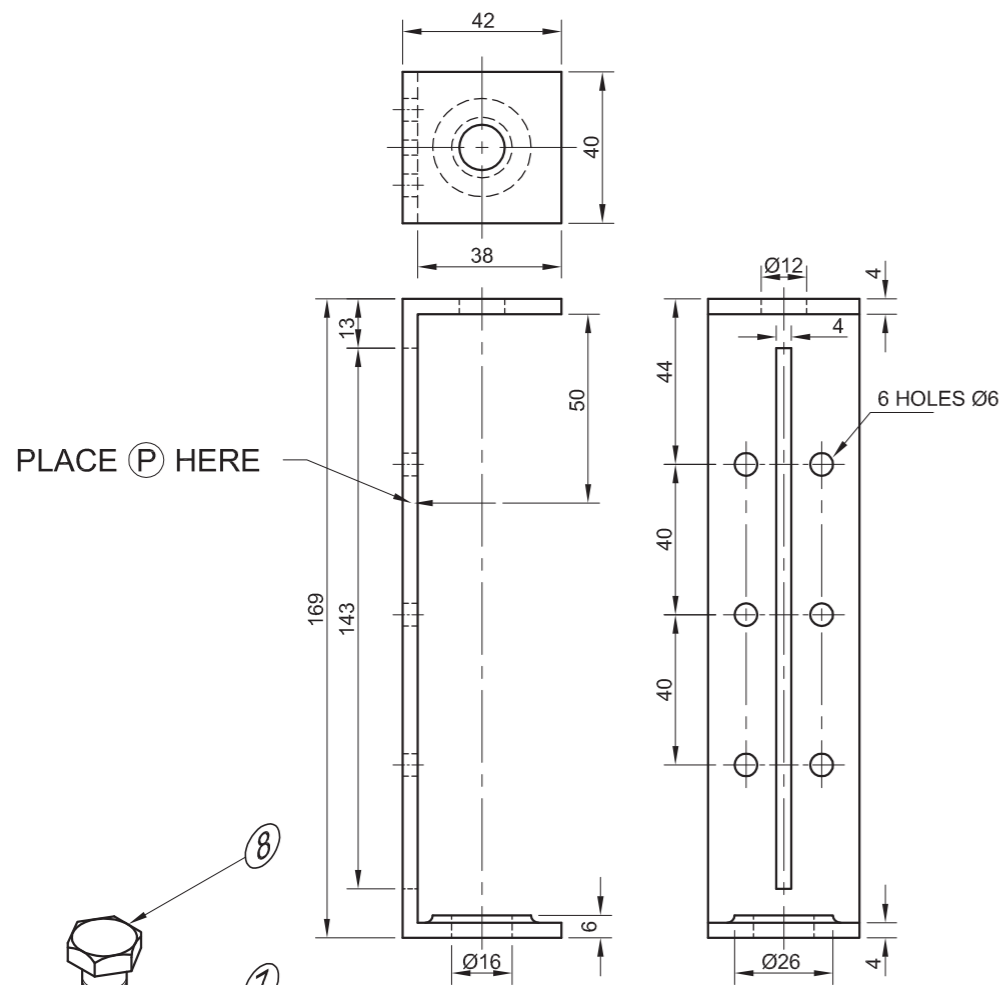

BRACKET [6]

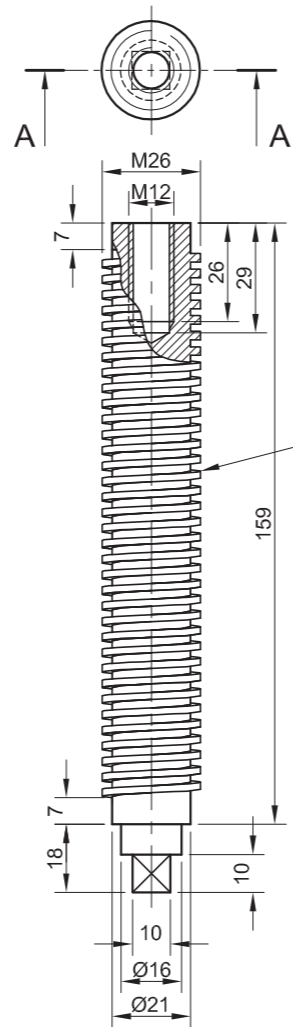

SHAFT [5]

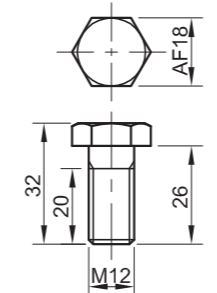

M12 BOLT [8]

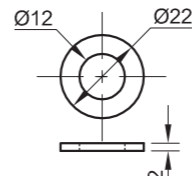

WASHER [7]

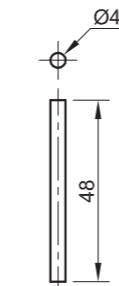

PIN [3]

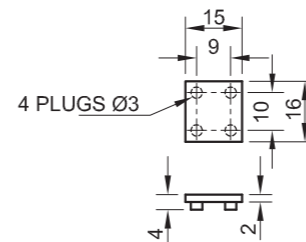

PAD [1]

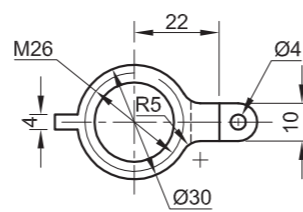

JACK [4]

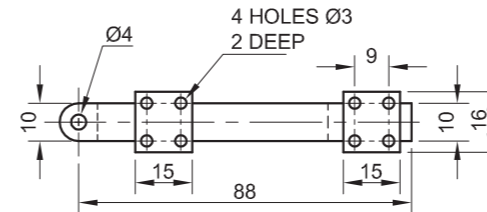

JACK ARM [2]

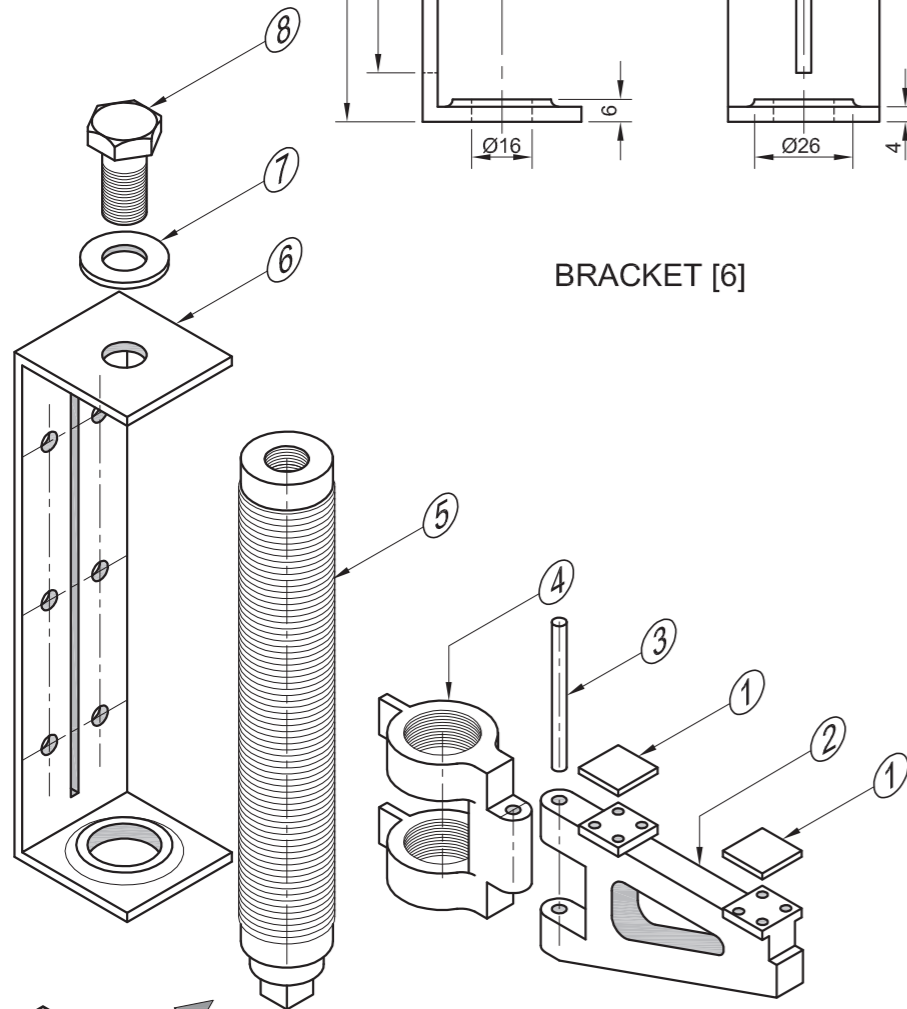

EXPLODED ISOMETRIC DRAWING

QUESTION 4: MECHANICAL ASSEMBLY

Given:

- The exploded isometric drawing of the parts of a jack assembly, showing the position of each part relative to all the others
- Orthographic views of each of the parts of the jack assembly

Instructions:

- Answer this question on page 6.
- Draw, to scale 1 : 1 and in third-angle orthographic projection, the following views of the assembled parts of the jack assembly:

4.1 A sectional front view on cutting plane A-A, as seen from the direction of the arrow shown on the exploded isometric drawing. The cutting plane, which passes through the vertical centre line of the assembly, is shown on the top view of the shaft (part 5).

4.2 The top view

- ALL drawings must comply with the guidelines contained in the SABS 0111.

NOTE:

- As indicated, place point P on the jack at point P on the bracket.
- Show THREE faces of the M12 bolt and ALL necessary construction.
- NO hidden detail is required.

Add the following features to the drawing:

- The cutting plane A-A
- Label the sectional view SECTION A-A.

[93]

PARTS LIST

PART	QUANTITY	MATERIAL
1. PAD	2	BRONZE
2. JACK ARM	1	CAST IRON
3. PIN	1	MILD STEEL
4. JACK	1	CAST IRON
5. SHAFT	1	MILD STEEL
6. BRACKET	1	MILD STEEL
7. WASHER	1	MILD STEEL
8. M12 BOLT	1	MILD STEEL

MECHTECH
ENGINEERING

17 LONG STREET
NEW PARK
KIMBERLEY 8300
www.mtech.co.za
053 645 7820

JACK ASSEMBLY

ALL DIMENSIONS ARE IN MILLIMETRES.

ALL UNSPECIFIED RADII ARE R2.



5



ASSESSMENT CRITERIA				
SECTIONAL FRONT VIEW				
1	PAD	3		
2	JACK ARM	11		
3	PIN	1		
4	JACK	7½		
5	SHAFT	14½		
6	BRACKET	7		
7	WASHER	1		
8	M12 BOLT	11		
9	HATCHING	13		
SUBTOTAL		69		
TOP VIEW				
1	OUTLINE	10		
2	M12 BOLT + WASHER	3		
SUBTOTAL		13		
GENERAL				
1	CENTRE LINES	2		
2	CUTTING PLANE + TITLE	4		
3	ASSEMBLY	5		
SUBTOTAL		11		
TOTAL		93		
EXAMINATION NUMBER				
EXAMINATION NUMBER				
				6

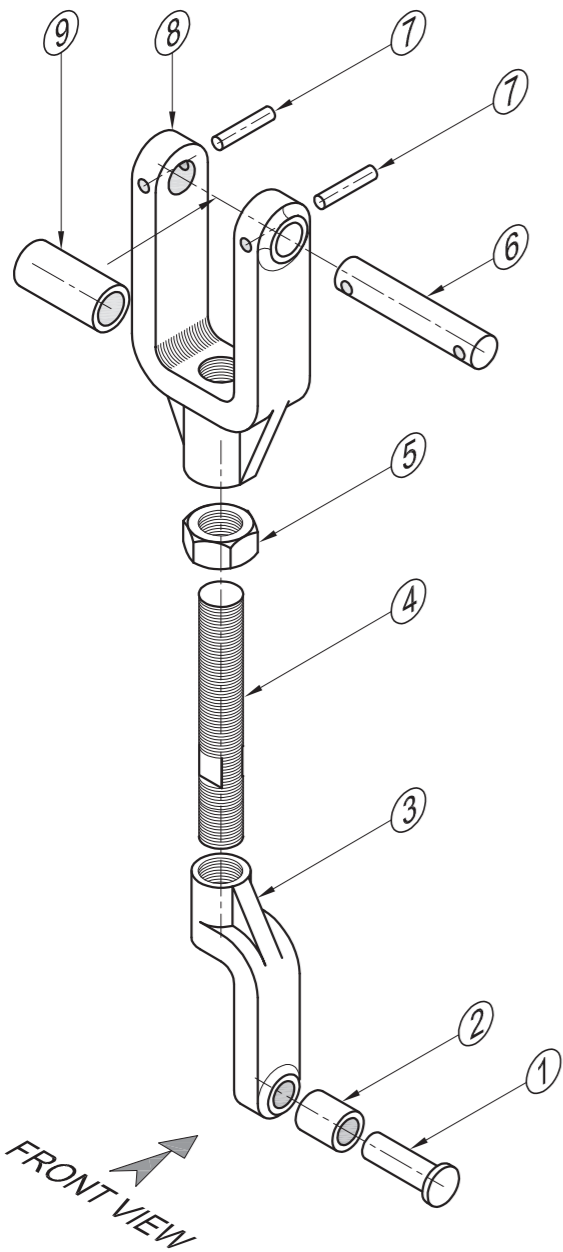

EXPLODED ISOMETRIC DRAWING

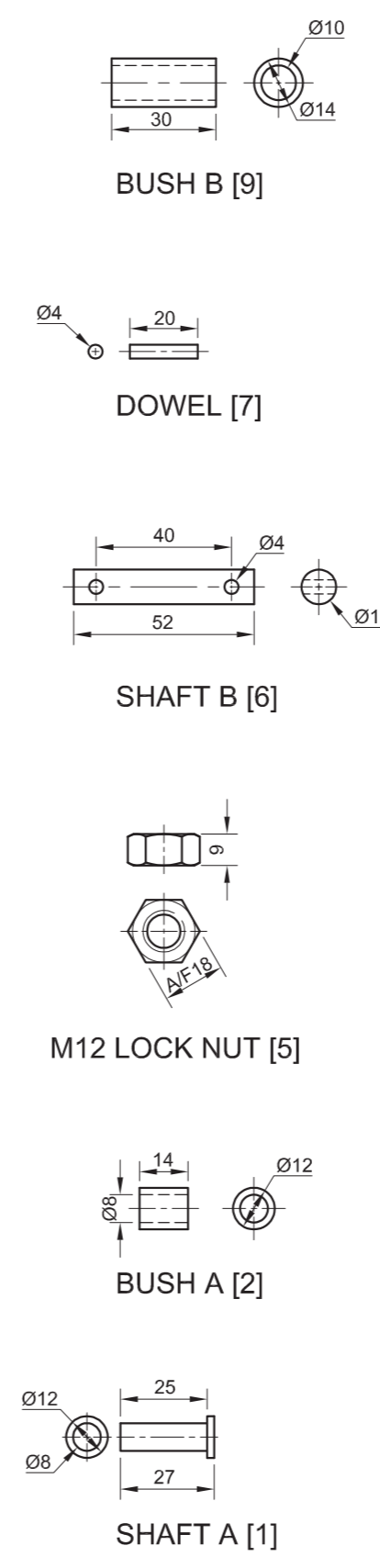
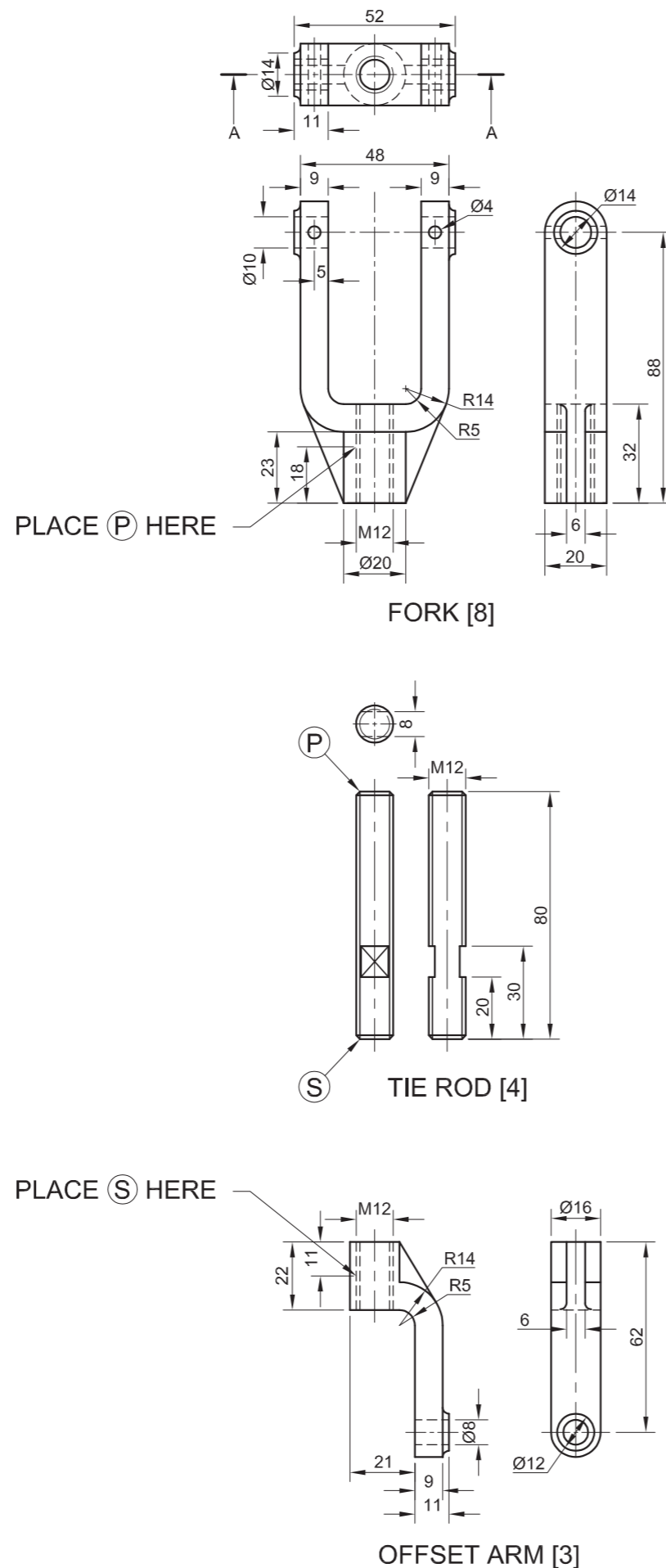

QUESTION 4: MECHANICAL ASSEMBLY

Given:

- The exploded isometric drawing of the parts of an offset connecting bar, showing the position of each part relative to all the others
- Orthographic views of each of the parts of the offset connecting bar assembly

Instructions:

- Answer this question on page 6.
- Draw, to scale 1 : 1 and in third-angle orthographic projection, the following views of the assembled parts of the offset connecting bar assembly:
 - 4.1 A sectional front view** on cutting plane A-A, as seen from the direction of the arrow shown on the exploded isometric drawing. The cutting plane, which passes vertically through the centre of the assembly, is shown on the top view of the fork (part 8).
 - 4.2 The right view**
- ALL drawing must comply with the guidelines contained in the SABS 0111.

NOTE:

- As indicated, place point P on the upper end of the tie rod with point P on the fork and point S on the lower end of the tie rod, with point S on the offset arm.
- Show THREE faces of the nut in the front view and ALL necessary construction.
- NO hidden detail is required.

Add the following features to the drawing:

- The cutting plane A-A
- Label the sectional view SECTION A-A.

[91]

PARTS LIST		
PART	QUANTITY	MATERIAL
1. SHAFT A	1	MILD STEEL
2. BUSH A	1	BRONZE
3. OFFSET ARM	1	CAST IRON
4. TIE ROD	1	MILD STEEL
5. M12 LOCK NUT	1	MILD STEEL
6. SHAFT B	1	MILD STEEL
7. DOWEL	2	MILD STEEL
8. FORK	1	CAST IRON
9. BUSH B	1	BRONZE



MECHTECH
ENGINEERING

17 LONG STREET
NEW PARK
KIMBERLEY 8300
www.mtech.co.za
053 645 7820

OFFSET CONNECTING BAR

ALL DIMENSIONS ARE IN MILLIMETRES.

ALL UNSPECIFIED RADII ARE R2.

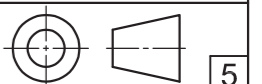

5





ASSESSMENT CRITERIA				
SECTIONAL FRONT VIEW				
1	SHAFT A	2		
2	BUSH A	1		
3	OFFSET ARM	7½		
4	TIE ROD	9		
5	M12 NUT	8		
6	SHAFT B	2		
7	DOWEL	1		
8	FORK	10½		
9	BUSH B	1		
H	HATCHING	12		
SUBTOTAL		54		
RIGHT VIEW				
3	OFFSET ARM	5½		
4	TIE ROD	5		
5	M12 NUT	4½		
8	FORK	6		
SUBTOTAL		21		
GENERAL				
1	CENTRE LINES	4		
2	CUTTING PLANE + TITLE	5		
3	ASSEMBLY	7		
SUBTOTAL		16		
TOTAL		91		
EXAMINATION NUMBER				
EXAMINATION NUMBER				
				6



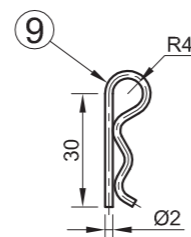
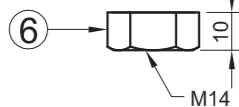
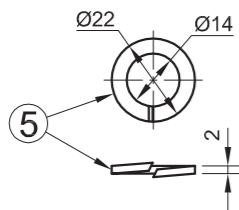
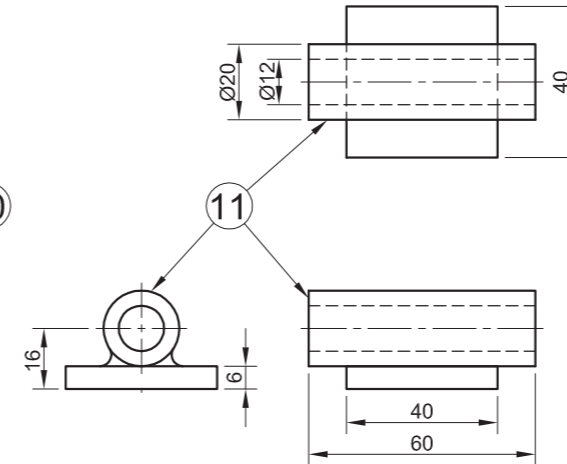
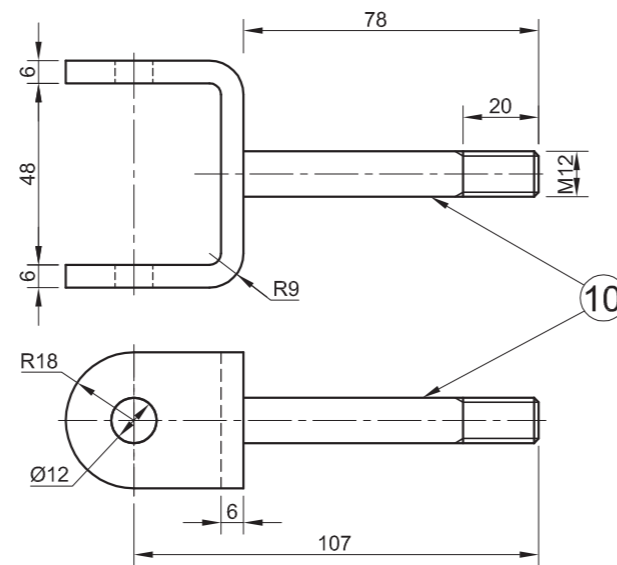
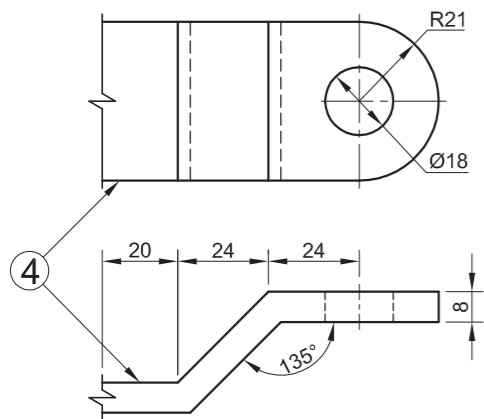
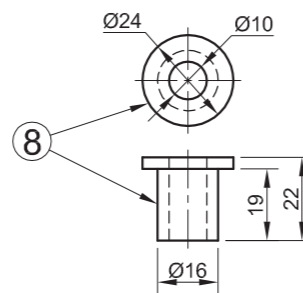
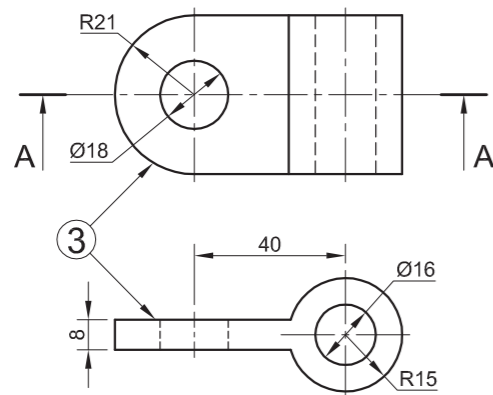
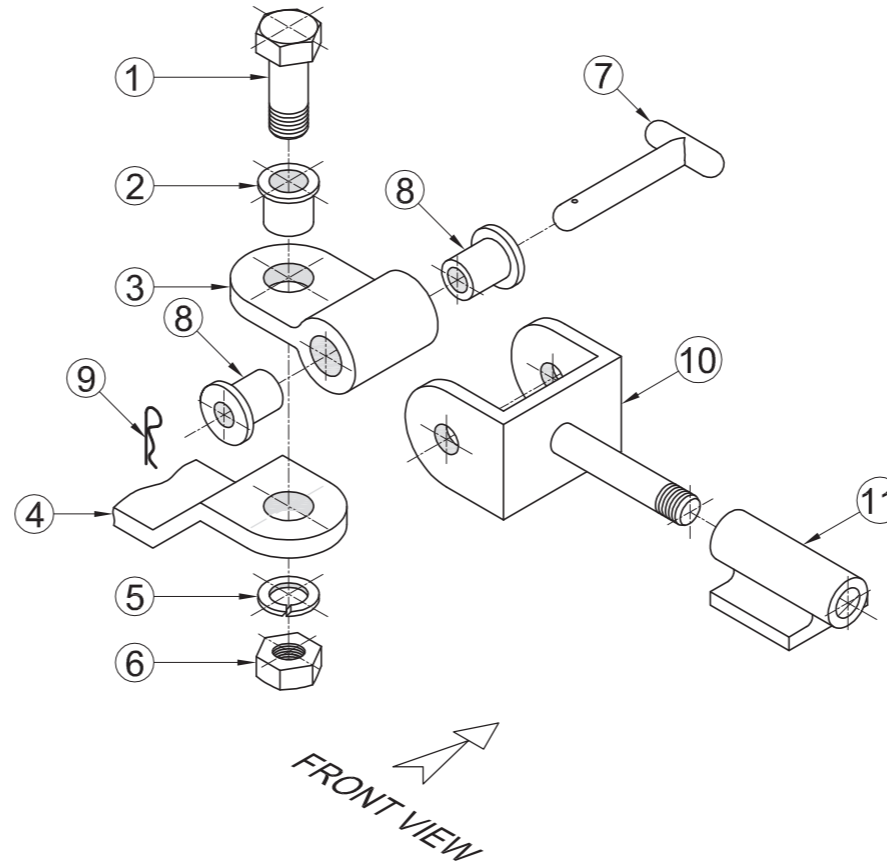
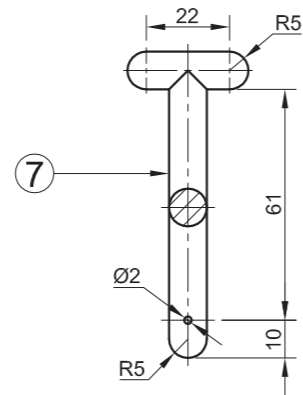
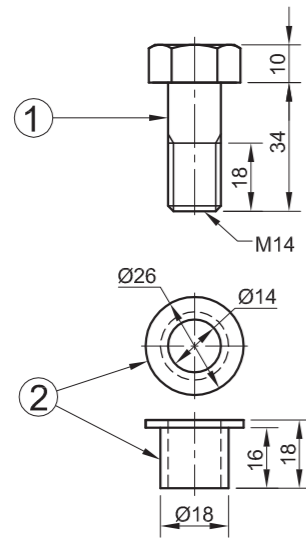

QUESTION 4: MECHANICAL ASSEMBLY

Given:

- The exploded isometric drawing of the parts of a coupling assembly for a trailer, showing the position of each part relative to all the others
- Orthographic views of each of the parts of the coupling assembly

Instructions:

- Answer this question on page 6.
- Draw, to scale 1 : 1 and in third-angle orthographic projection, the following views of the assembled parts of the coupling assembly:
 - 4.1 A sectional front view** on cutting plane A-A, as seen from the arrow shown on the exploded isometric drawing. The cutting plane is shown on the top view of the swivel (part 3).
 - 4.2 The top view.**
- ALL drawings must comply with the guidelines contained in the SABS 0111.

NOTE:

- Show THREE faces of the M14 bolt and nut and ALL necessary construction.
- NO hidden detail is required.

Add the following feature to the drawing:

- The cutting plane A-A

[97]

PARTS LIST		
PART	QUANTITY	MATERIAL
1. M14 BOLT	1	MILD STEEL
2. BUSH	1	HIGH-TENSILE STEEL
3. SWIVEL	1	MILD STEEL
4. FIXED ARM	1	MILD STEEL
5. SPRING WASHER	1	HARDENED STEEL
6. M14 NUT	1	MILD STEEL
7. PIN	1	HARDENED STEEL
8. BUSH	2	NYLON
9. LOCKING PIN	1	SPRING STEEL
10. YOKE	1	MILD STEEL
11. MOUNTING BRACKET	1	MILD STEEL

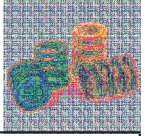
ALL DIMENSIONS ARE IN MILLIMETRES.	DRAWN BY: <i>NDVHUMO</i>	IBAYHI STEEL MANUFACTURING OLD CAPE ROAD GREENBUSHES 6025 www.ibayhisteel.co.za	
	DATE: 23/05/2010		
	CHECKED BY: <i>MARY</i>		
ALL UNSPECIFIED RADII ARE R3.	DATE: 12/06/2010	TITLE	TRAILER COUPLING
DRAWING PROGRAM: AUTOCAD 2008	APPROVED BY: <i>PHATHU</i>	NATIONAL SENIOR CERTIFICATE GRADE 12 FEB./MAR. 2011	
	DATE: 05/01/2010		
	SCALE: 1 : 2		5





ASSESSMENT CRITERIA				
TOP VIEW				
	POSSIBLE	OBTAINED	SIGN	MODERATE
1. M14 BOLT	3			
2. BUSH	1			
3. SWIVEL	3			
4. FIXED ARM	2½			
5. PIN	4			
6. BUSH	2			
7. LOCKING PIN	1			
8. YOKE	10			
9. MOUNTING BRACKET	4½			
SUBTOTAL	31			
SECTIONAL FRONT VIEW				
1. M14 BOLT	10½			
2. BUSH	3½			
3. SWIVEL	3½			
4. FIXED ARM	4			
5. SPRING WASHER	2½			
6. M14 NUT	5			
7. PIN	1			
8. YOKE	9			
9. MOUNTING BRACKET	4			
SUBTOTAL	43			
GENERAL				
THIRD ANGLE	2			
◇ CENTRE LINES	3			
⊗ SECTION A-A	4			
▲ HATCHING	9			
ASSEMBLY ½ MARK OF EVERY PART CORRECTLY ASSEMBLED	5			
SUBTOTAL	23			
TOTAL	97			

EXAMINATION NUMBER	
EXAMINATION NUMBER	6



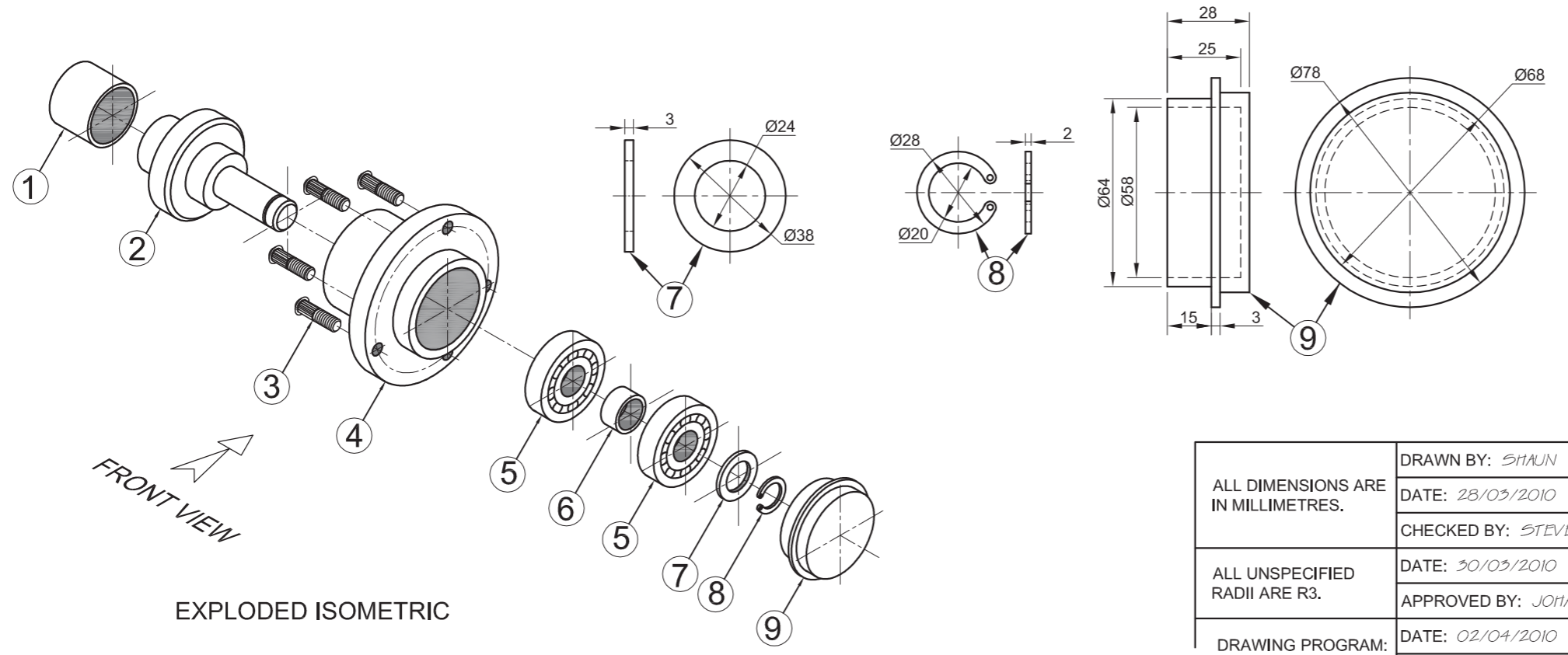
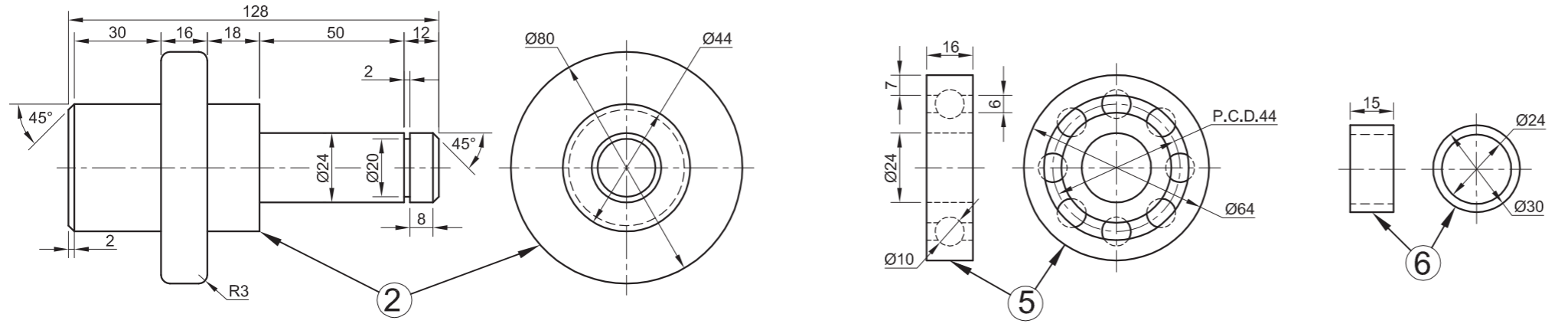
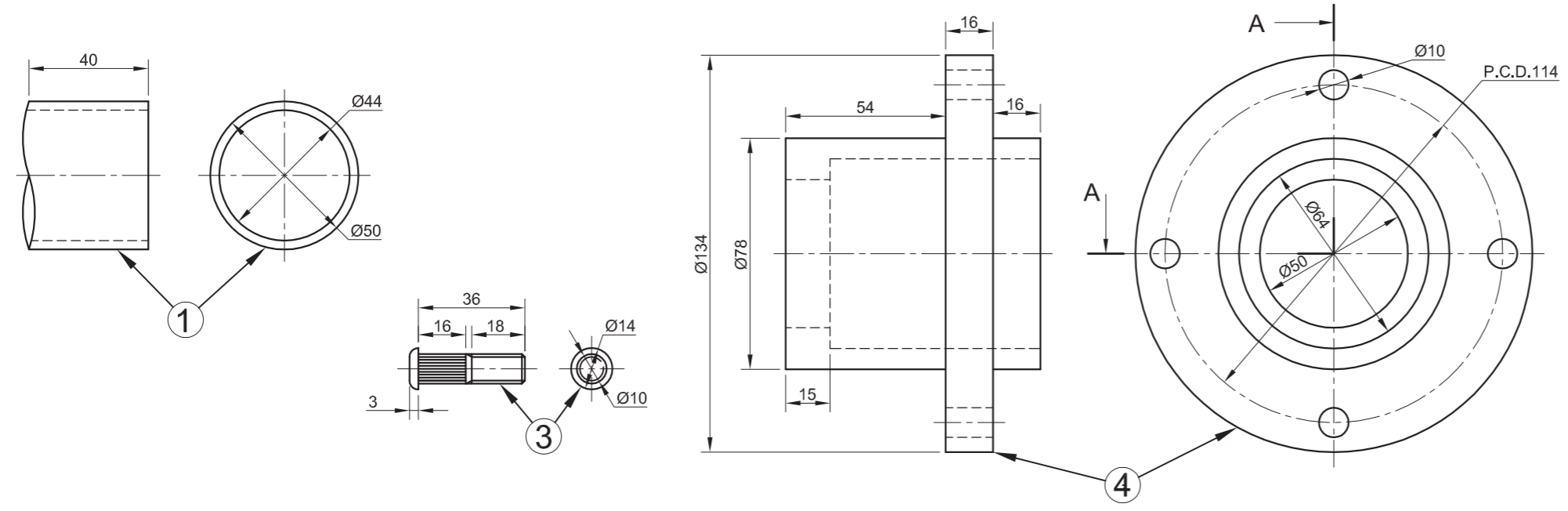

QUESTION 4: MECHANICAL ASSEMBLY

Given:

- The exploded isometric drawing of the parts of a wheel-hub assembly for a trailer, showing the position of each part relative to all the others
- Orthographic views of each of the parts of the wheel-hub assembly for a trailer

Instructions:

- Answer this question on page 6.
- Draw, to scale 1 : 1 and in third-angle orthographic projection, the following views of the assembled parts of the wheel-hub assembly for a trailer:

4.1 A half-sectional front view, with the top half in section, on cutting plane A-A, as seen from the direction of the arrow shown on the exploded isometric drawing. The cutting plane is shown on the right view of the wheel hub (part 4).

4.2 The right view with the hub cap removed.

- ALL drawings must comply with the guidelines contained in the SABS 0111.

NOTE:

- Only the top wheel stud must be shown in the assembly.
- The ball bearings must be drawn in detail.
- No hidden detail is required.

Add the following features to the drawing:

- The cutting plane A-A
- Label the half-sectional view: SECTION A-A [97]

PARTS LIST		
PART	QUANTITY	MATERIAL
1. AXLE PIPE	1	MILD STEEL
2. STUB AXLE	1	MILD STEEL
3. WHEEL STUD	4	HARDENED STEEL
4. WHEEL HUB	1	CAST IRON
5. BALL BEARING	2	HARDENED STEEL
6. SPACER	1	MILD STEEL
7. WASHER	1	MILD STEEL
8. CIRCLIP	1	SPRING STEEL
9. HUB CAP	1	MILD STEEL

ALL DIMENSIONS ARE IN MILLIMETRES.	DRAWN BY: SHAWN	<p>RHINO STEEL</p> <p>MANUFACTURING</p> <p>FOREST DRIVE AMALINDA 5247 www.rhinosteel.co.za</p>	
	DATE: 28/05/2010		
	CHECKED BY: STEVEN		
ALL UNSPECIFIED RADII ARE R3.	DATE: 30/03/2010	TITLE	<p>TRAILER-WHEEL HUB ASSEMBLY</p>
	APPROVED BY: JORIAN		
DRAWING PROGRAM: AUTOCAD 2008	DATE: 02/04/2010	NATIONAL SENIOR CERTIFICATE GRADE 12 NOVEMBER 2010	
	SCALE: 1 : 1		





ASSESSMENT CRITERIA				
HALF-SECTIONAL FRONT VIEW				
	POSSIBLE	OBTAINED	SIGN	MODERATE
THIRD ANGLE	2			
1. AXLE PIPE	3			
2. STUB AXLE	9½			
3. WHEEL STUD	8½			
4. WHEEL HUB	8			
5. BEARINGS	7			
6. SPACER	1			
7. WASHER	1½			
8. CIRCLIP	1½			
9. HUB CAP	5			
SUBTOTAL	47			
RIGHT VIEW + GENERAL				
1. WHEEL HUB	4½			
2. WHEEL STUD	2			
3. BEARING	9			
4. WASHER	1			
5. CIRCLIP	3			
6. STUB AXLE	2			
7. ASSEMBLY	9			
8. SECTION A-A	4			
9. CENTRE LINES	4			
10. HATCHING	11½			
SUBTOTAL	50			
TOTAL	97			

EXAMINATION NUMBER	
EXAMINATION NUMBER	6



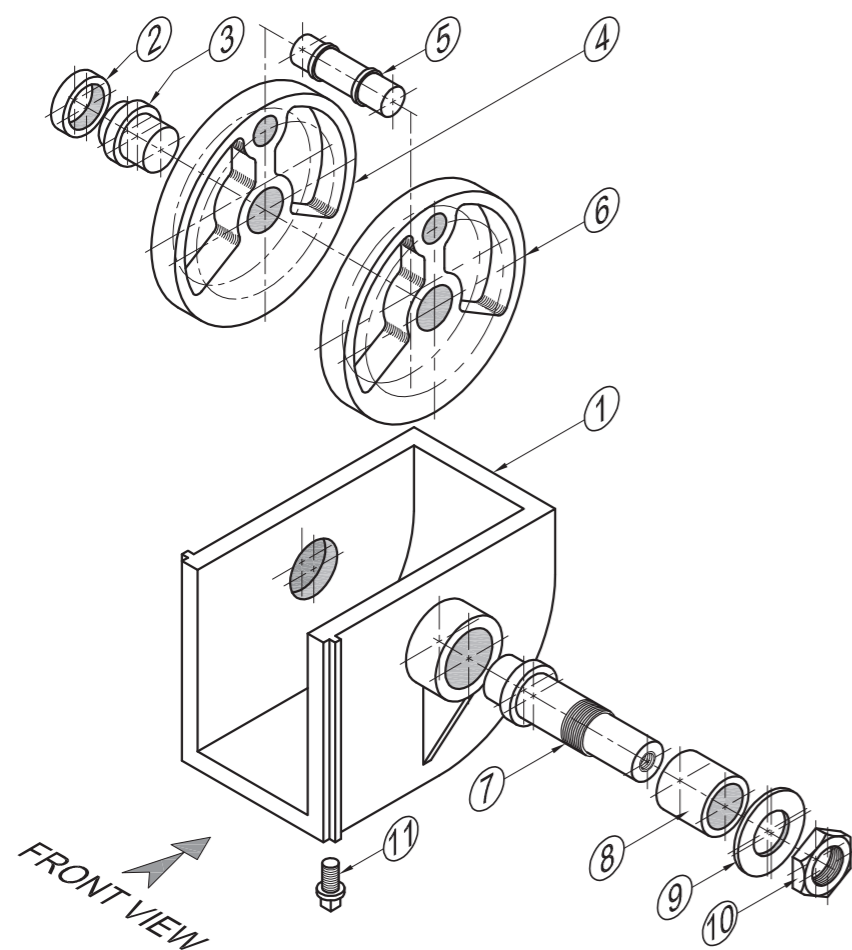

EXPLODED ISOMETRIC DRAWING

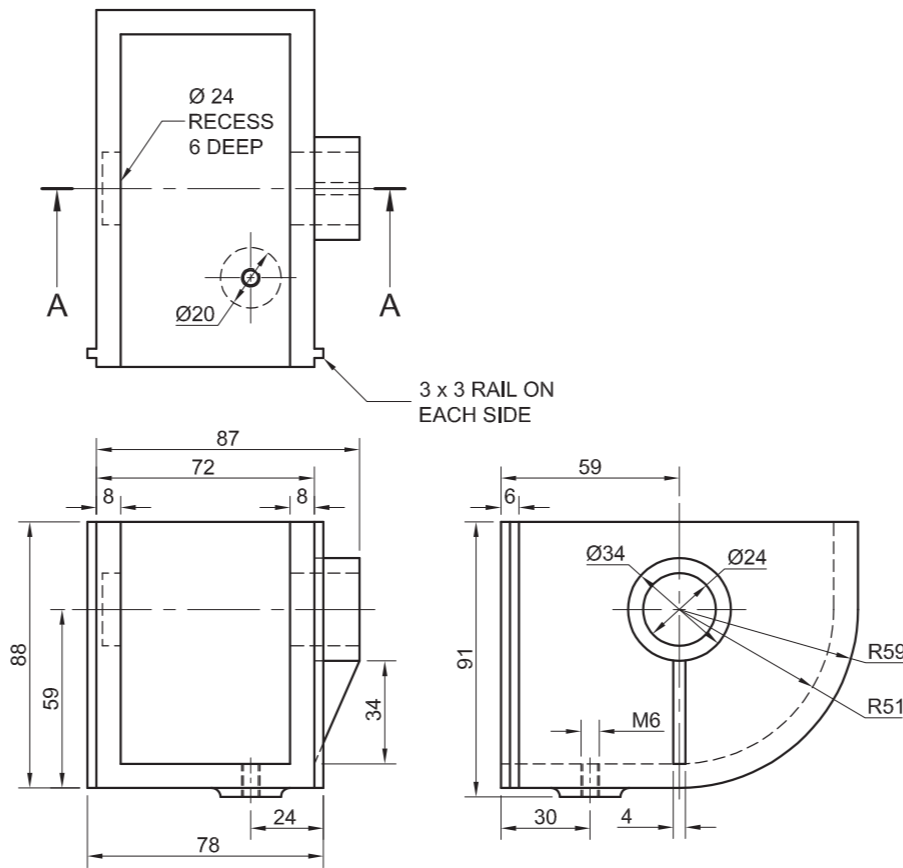

HOUSING [1]

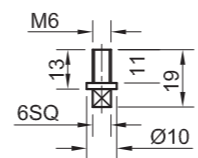

DRAIN PLUG [11]

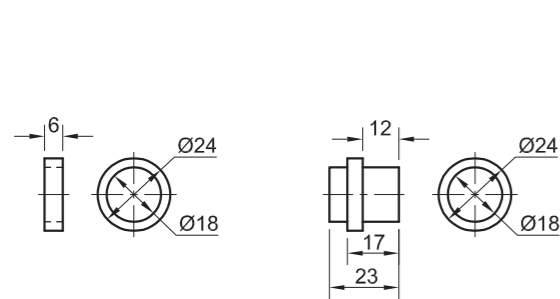

BUSH A [2]

SHORT SHAFT [3]

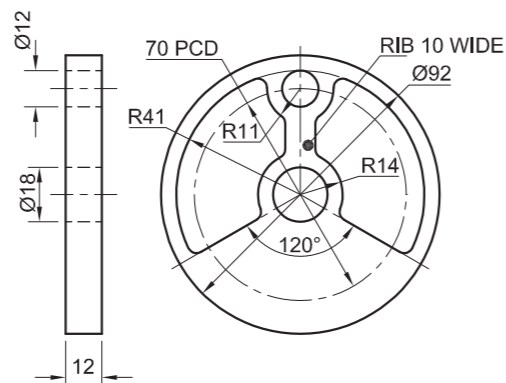

LEFT FLYWHEEL [4]

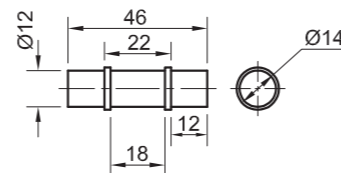

JOURNAL [5]

NOTE:
SHOW THE JOURNAL IN
THE HIGHEST POSITION.

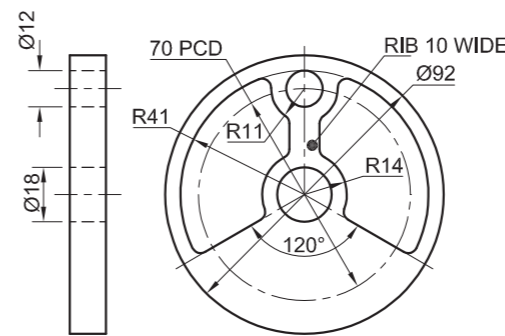

RIGHT FLYWHEEL [6]

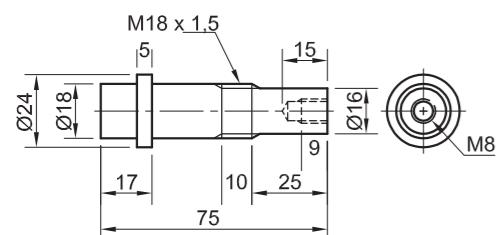

DRIVE SHAFT [7]

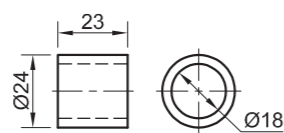

BUSH B [8]

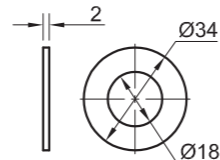

WASHER [9]

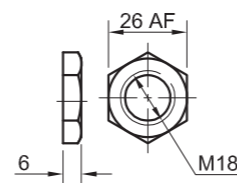

SPECIAL NUT [10]

QUESTION 4: ASSEMBLY DRAWING

Given:

- The exploded isometric drawing of the parts of a crank assembly, showing the position of each part relative to all the others
- Orthographic views of each of the parts of the crank assembly

Instructions:

- Answer this question on page 6.
- Draw, to scale 1:1 and in third-angle orthographic projection, the following views of the assembled parts of the crank assembly:

4.1 The sectional front view on cutting plane A-A, as seen from the direction of the arrow shown in the exploded isometric drawing. The vertical cutting plane passes through the centre line of the assembly, as shown on the top view of the housing.

4.2 The right view. NO hidden detail is required.

- ALL drawings must comply with the guidelines contained in the SABS 0111.

Add the following features to the drawing:

- The cutting plane A-A
- Label the sectional view: SECTION A-A.

NOTE:

Show THREE faces of the special nut and ALL necessary construction. [94]

PARTS LIST

PART	QUANTITY	MATERIAL
1. HOUSING	1	CAST IRON
2. BUSH A	1	BRONZE
3. SHORT SHAFT	1	MILD STEEL
4. LEFT FLYWHEEL	1	CAST IRON
5. JOURNAL	1	MILD STEEL
6. RIGHT FLYWHEEL	1	CAST IRON
7. DRIVE SHAFT	1	MILD STEEL
8. BUSH B	1	BRONZE
9. WASHER	1	MILD STEEL
10. SPECIAL NUT	1	MILD STEEL
11. DRAIN PLUG	1	MILD STEEL

eBHAYI

ENGINEERING PTY (LTD)

73 ACACIA AVENUE
PORT ELIZABETH
6001

041 645 7820

CRANK ASSEMBLY

ALL DIMENSIONS ARE
IN MILLIMETRES.

ALL UNSPECIFIED
RADII ARE 3.

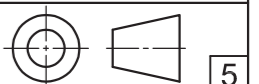



ASSESSMENT CRITERIA					
SECTIONAL FRONT VIEW					
		POSSIBLE	OBTAINED	SIGN	MODERATE
1	HOUSING	7			
2	BUSH A + SHORT SHAFT	5			
3	FLYWHEELS	6			
4	JOURNAL	4			
5	BUSH B + DRIVE SHAFT	11½			
6	WASHER + NUT	7			
7	HATCHING + NON-HATCHING	14			
8	LABELS + CENTRE LINES	2			
SUBTOTAL		56½			
RIGHT VIEW					
1	HOUSING	6½			
2	DRAIN PLUG	4			
3	FLYWHEEL	4			
4	DRIVE SHAFT	2			
5	NUT + WASHER	4			
6	CUTTING PLANE + CENTRE LINES	5			
7	3RD ANGLE RIGHT VIEW	2			
8	ASSEMBLY	10			
SUBTOTAL		37½			
TOTAL		94			
EXAMINATION NUMBER					
EXAMINATION NUMBER					
6					

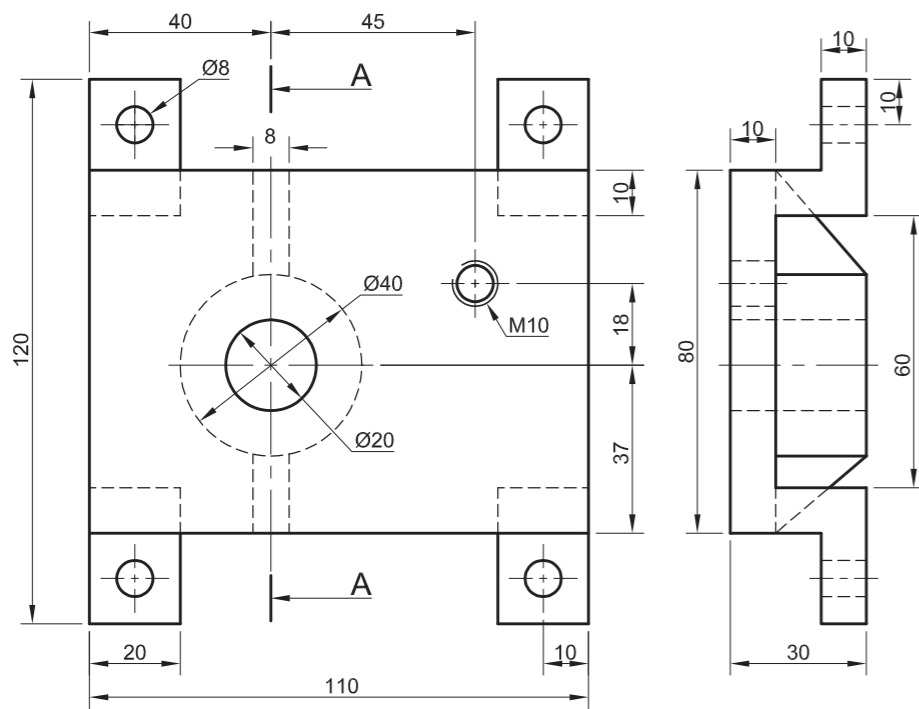

BASE [2]

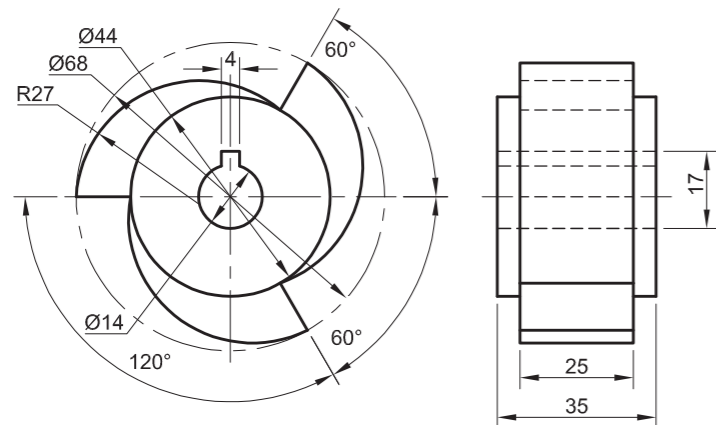

RATCHET [4]

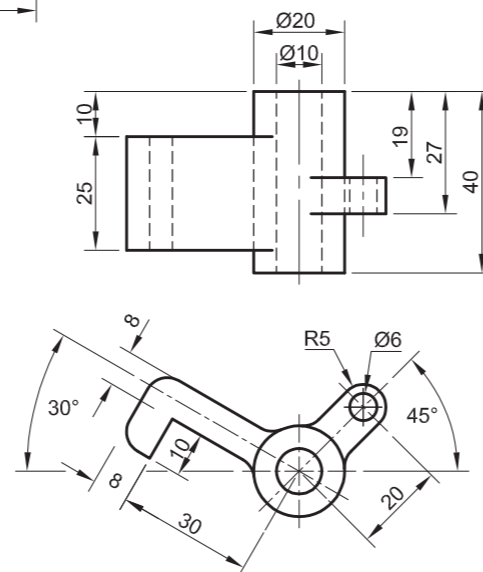

RATCHET ARM [9]

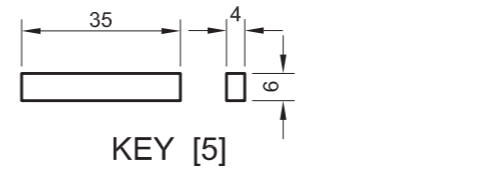

KEY [5]

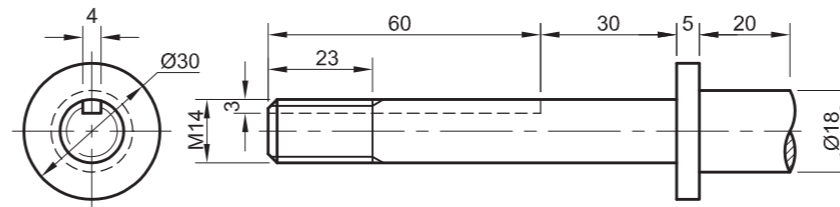

SHAFT [1]

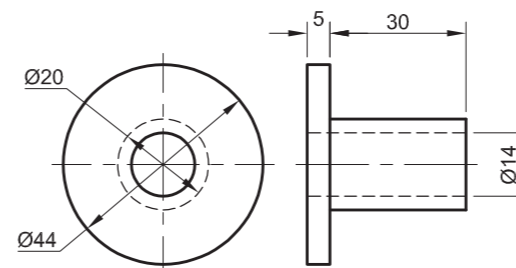

BUSH [3]

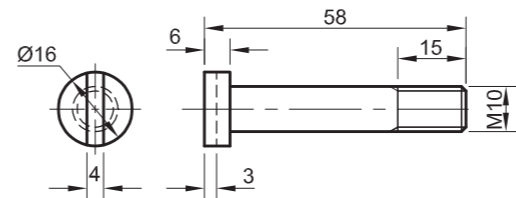

SCREW [8]

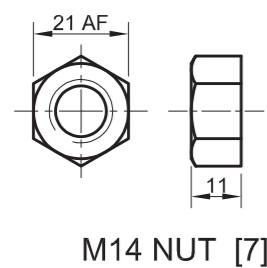

M14 NUT [7]

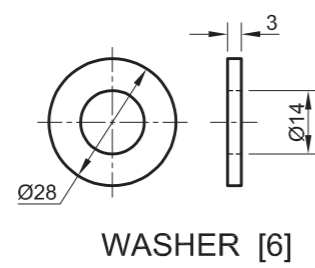

WASHER [6]

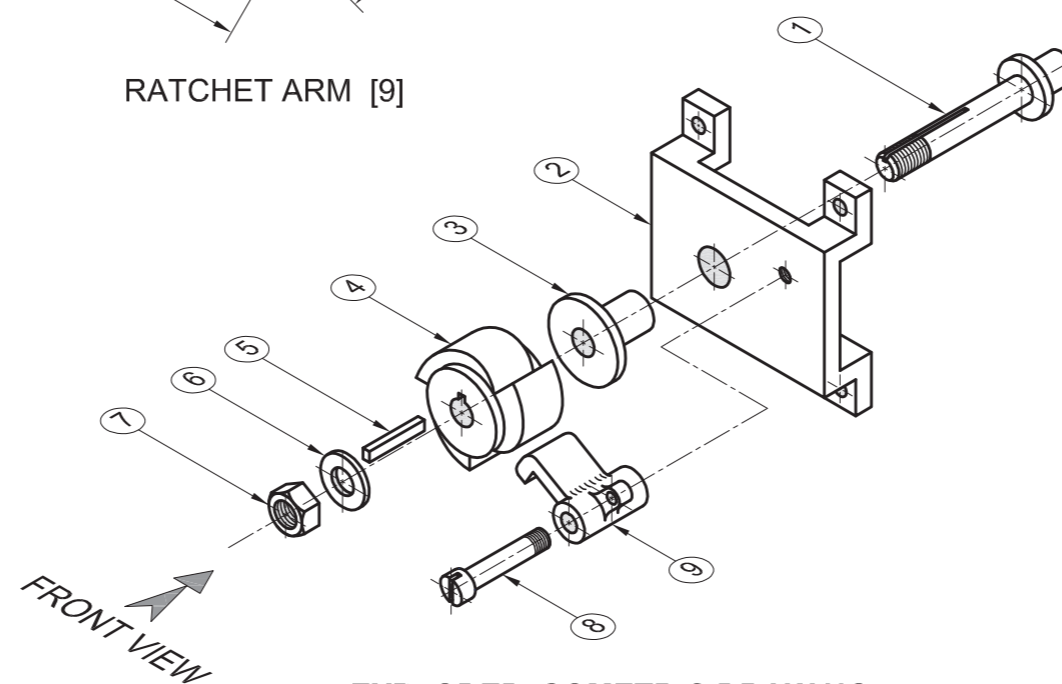

EXPLODED ISOMETRIC DRAWING

QUESTION 4: ASSEMBLY DRAWING

Given:

The exploded isometric drawing of the parts of a ratchet and base, showing the position of each part relative to all the others.

Orthographic views of each of the parts of the ratchet and base.

Instructions:

Answer this question on page 6.

Draw, to scale 1:1 and in third-angle orthographic projection, the following views of the assembled parts of the ratchet and base:

4.1 The front view as seen from the direction of the arrow indicated in the exploded isometric drawing. NO hidden detail is required.

4.2 A sectional right view on cutting plane A-A. The vertical cutting plane passes through the centre line of the assembly, as shown on the front view of the base.

- ALL drawings must comply with the guidelines contained in the SABS 0111.

Add the following feature to the drawing:

- The cutting plane A-A

Note:

- Show THREE faces of the M14 nut and ALL necessary construction. **[93]**

PARTS LIST

PART	QUANTITY	MATERIAL
1. SHAFT	1	MILD STEEL
2. BASE	1	MILD STEEL
3. BUSH	1	BRASS
4. RATCHET	1	CAST IRON
5. KEY	1	MILD STEEL
6. WASHER	1	SPRING STEEL
7. M14 NUT	1	MILD STEEL
8. SCREW	1	MILD STEEL
9. RATCHET ARM	1	CAST IRON

**EGD
ENGINEERING**
(SA) (PTY) LTD

188 SCHOEMAN STREET
PRETORIA
0001
www.egdengineering.co.za
012 555 2345

RATCHET AND BASE

ALL DIMENSIONS ARE
IN MILLIMETRES

ALL UNSPECIFIED
RADII ARE 5

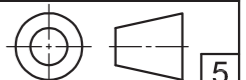



ASSESSMENT CRITERIA				
SECTIONAL VIEW				
	POSSIBLE	OBTAINED	SIGN	MODERATE
1. BASE	10			
2. SHAFT	11			
3. BUSH	3			
4. RATCHET	6			
5. KEY	1½			
6. WASHER + M14 NUT	6½			
7. HATCHING	10½			
FRONT VIEW				
1. BASE	8			
2. SHAFT	2½			
3. WASHER + M14 NUT	3			
4. RATCHET	3½			
5. RATCHET ARM	7½			
6. PIN	1½			
7. CUTTING PLANE A-A	3			
CENTRE LINES	$15 \times \frac{1}{2} = 7\frac{1}{2}$			
ASSEMBLY	6			
3rd ANGLE	2			
TOTAL	93			
EXAMINATION NUMBER				
EXAMINATION NUMBER				6

QUESTION 4: ASSEMBLY DRAWING

Given:

The exploded isometric drawing of the parts of a vertical support bracket, showing the position of each part relative to all the others.

Orthographic views of each of the parts of the vertical support bracket.

Instructions:

Answer this question on ANSWER SHEET 4 on page 6. Draw to scale 1:2 the following views of the assembled parts of the vertical support bracket:

- 4.1 The full sectional front view on A-A as seen from the arrow indicated in the exploded isometric drawing. The vertical cutting plane passes through the centre line of the assembly as shown on the top view of the support bracket.
- 4.2 A top view of the the assembly. No hidden detail is required.

- ALL drawing must comply with the guidelines contained in the SABS 0111.

Add the following feature to the drawing:

- The cutting plane. Label it A A.

Note:

- Show THREE faces of the M44 nut and ALL necessary construction. [95]

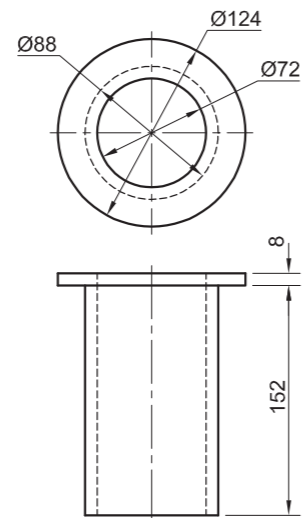

BUSH

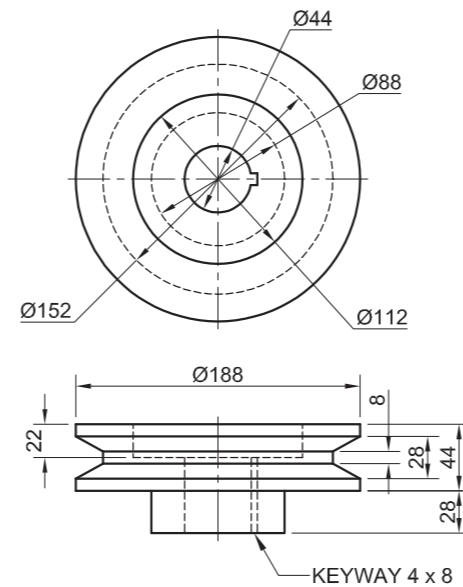

PULLEY

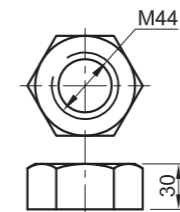

M44 NUT

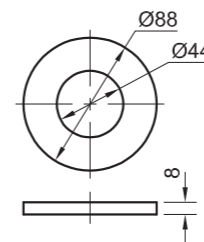

WASHER

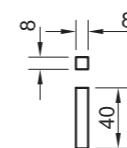

KEY

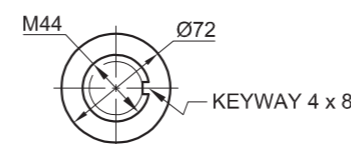

SHAFT

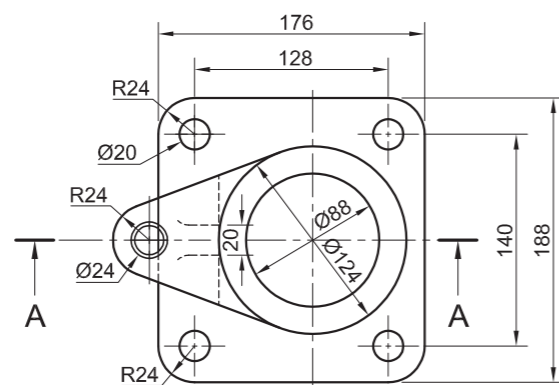

SUPPORT BRACKET

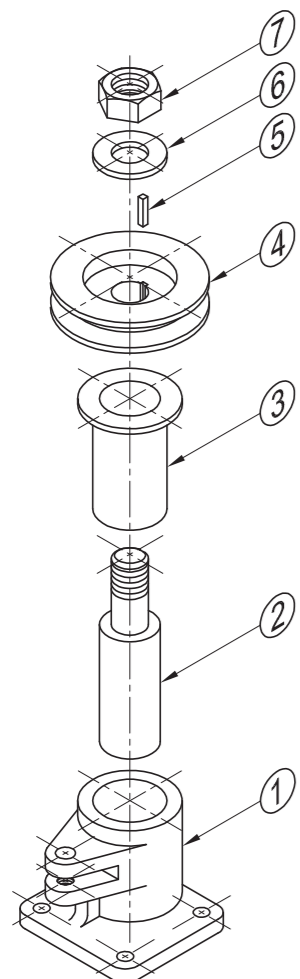
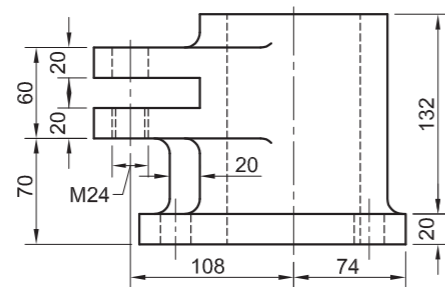

EXPLODED ISOMETRIC

FRONT VIEW

PARTS LIST		
PART	QUANTITY	MATERIAL
1. SUPPORT BRACKET	1	CAST IRON
2. SHAFT	1	MILD STEEL
3. BUSH	1	BRASS
4. PULLEY	1	CAST IRON
5. KEY	1	MILD STEEL
6. WASHER	1	SPRING STEEL
7. M44 NUT	1	MILD STEEL

ALL DIMENSIONS ARE IN MILLIMETRES	DRAWN: SIBU	<p style="text-align: center;">CAPE STEEL</p> FOREST DRIVE GOODWOOD 5240 www.capesteel.co.za
	DATE: 22/10/08	
	CHECKED: PENNY	
ALL UNSPECIFIED RADII ARE R10	DATE: 25/10/08	TITLE <p style="text-align: center;">VERTICAL SUPPORT BRACKET</p>
	APPROVED: SAREL	
DRAWING PROGRAM: AUTOCAD 2008	DATE: 26/10/08	NATIONAL SENIOR CERTIFICATE GRADE 12 NOVEMBER 2008
	SCALE: 1:1	

ANSWER SHEET 4



ASSESSMENT CRITERIA						
FRONT VIEW	FACET		SECTIONING		TOTAL	
	POSSIBLE	OBTAINED	POSSIBLE	OBTAINED	POSSIBLE	OBTAINED
1. SUPPORT BRACKET	16		5		21	
2. SHAFT	10 $\frac{1}{2}$		1 $\frac{1}{2}$		12	
3. BUSH	3		1		4	
4. PULLEY	10		2		12	
5. KEY	1		$\frac{1}{2}$		1 $\frac{1}{2}$	
6. WASHER	1 $\frac{1}{2}$		$\frac{1}{2}$		2	
7. M44 NUT	5		$\frac{1}{2}$		5 $\frac{1}{2}$	
TOP VIEW	FACET		SECTIONING		TOTAL	
	POSSIBLE	OBTAINED	POSSIBLE	OBTAINED	POSSIBLE	OBTAINED
1. SUPPORT BRACKET	13 $\frac{1}{2}$				13 $\frac{1}{2}$	
2. SHAFT	2				2	
3. PULLEY	2				2	
4. WASHER	1				1	
5. M44 NUT	4				4	
6. CUTTING PLANE A A	2				2	
CENTRE LINES					6 $\frac{1}{2}$	
ASSEMBLY					6	
TOTAL					95	

EXAMINATION NUMBER	
EXAMINATION NUMBER	6

ANSWER SHEET 4



ASSESSMENT CRITERIA						
	FACET		SECTIONING		TOTAL	
	POSSIBLE	OBTAINED	POSSIBLE	OBTAINED	POSSIBLE	OBTAINED
1. SHAFT	8½		½		9	
2. KEY	1		1½		2½	
3. BUSH	4		3		7	
4. HANGER BRACKET	15		4½		19½	
5. PULLEY	14		3		17	
6. WASHER	1		½		1½	
7. M18 NUT	6½		½		7	
8. MOUNTING PLATE	12		3		15	
9. COLLAR	2		1		3	
10. PIN	1		½		1½	
CENTRE LINES					5	
ASSEMBLY					10	
TOTAL					98	

EXAMINATION NUMBER	
EXAMINATION NUMBER	6

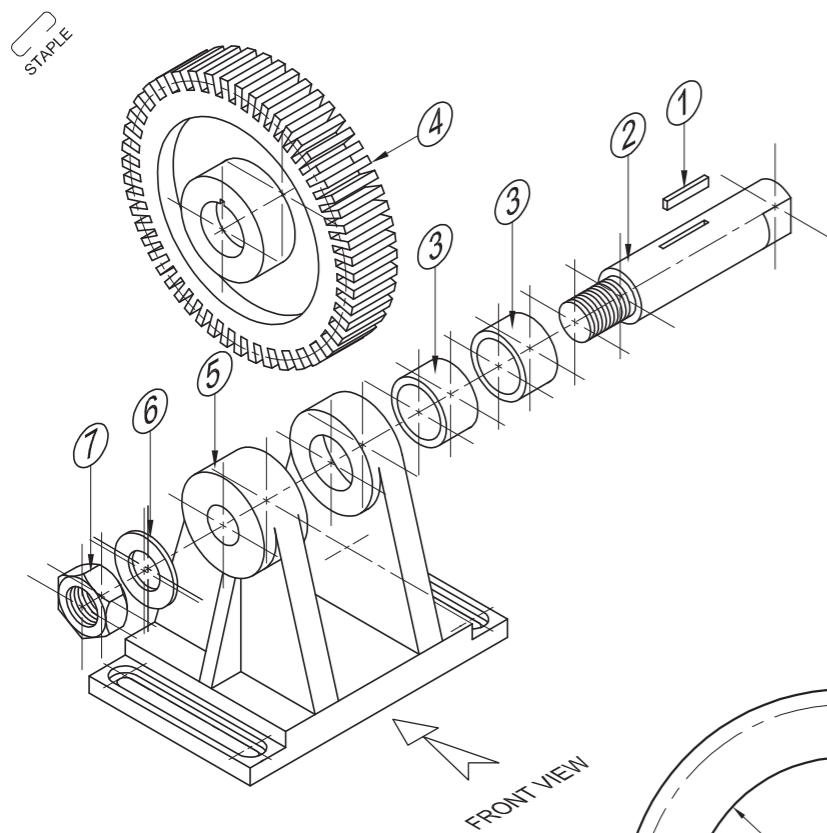

QUESTION 4: ASSEMBLY DRAWING

Given:

The exploded isometric drawing of the parts of a spur gear sub-assembly, showing the position of each part relative to all the others.

Orthographic views of each of the parts of the spur gear sub-assembly.

Instructions:

Answer this question on ANSWER SHEET 4 on page 5.

Draw, to scale 1:1, the following views of the assembled parts of the spur gear sub-assembly:

- The full sectional front view on A-A as seen from the arrow indicated in the exploded isometric drawing. The cutting plane passes through the vertical centre line of the assembly as shown on the housing bracket. Label the sectioned view.
- The left view. NO hidden detail is required. Show the cutting plane.

Note:

- Show THREE faces of the M16 nut and ALL necessary construction.
- Draw the conventional representation of the spur gear in accordance with the SABS 0111.
- ALL drawing must comply with the guidelines contained in the SABS 0111.

[90]

EXPLODED ISOMETRIC DRAWING

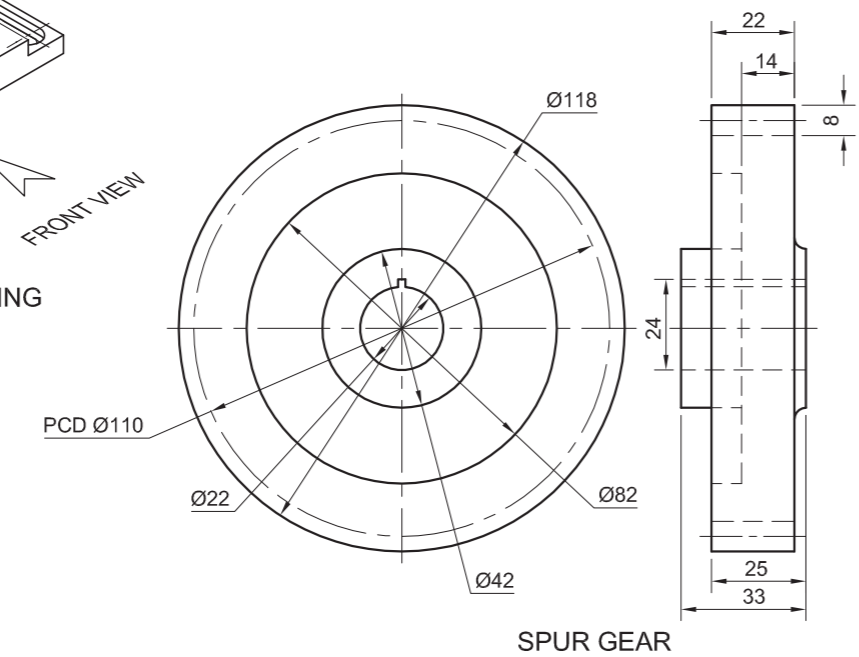

SPUR GEAR

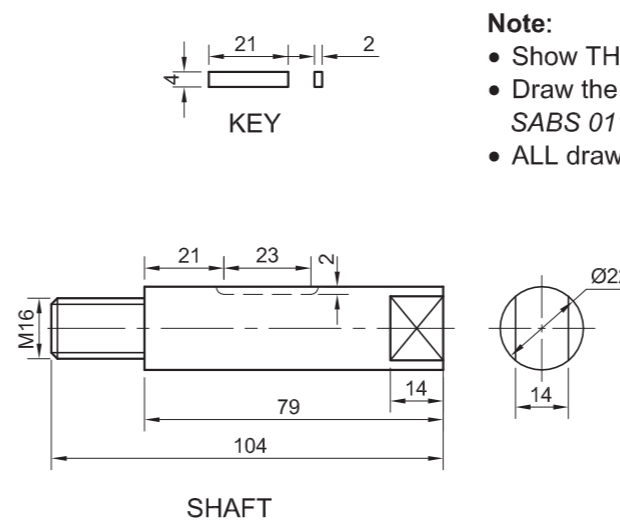

SHAFT

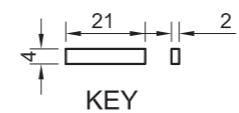

KEY

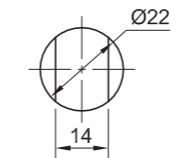

BUSH

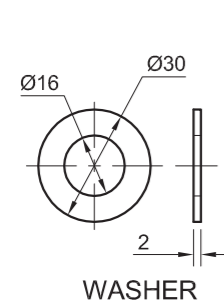

WASHER

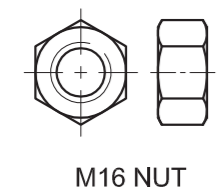

M16 NUT

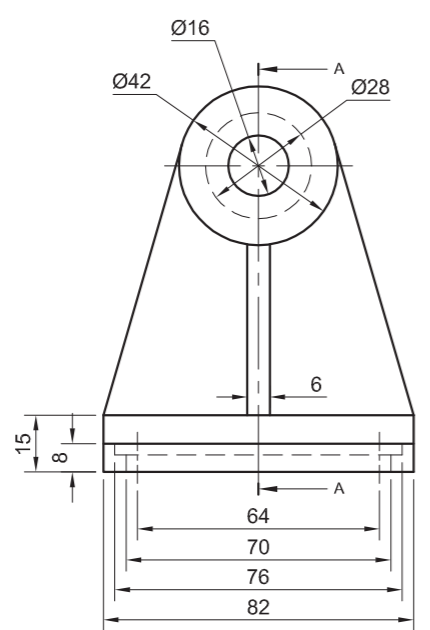

HOUSING BRACKET

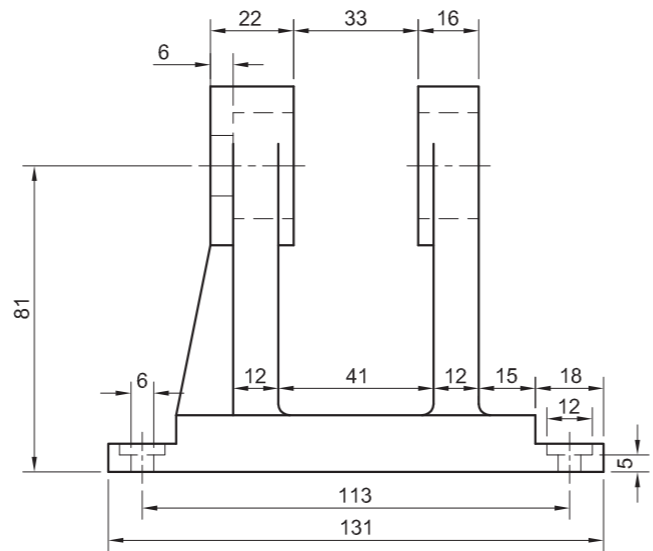

PARTS LIST		
PART	QUANTITY	MATERIAL
1. KEY	1	MILD STEEL
2. SHAFT	1	MILD STEEL
3. BUSH	2	BRASS
4. SPUR GEAR	1	MILD STEEL
5. HOUSING BRACKET	1	CAST IRON
6. WASHER	1	SPRING STEEL
7. M16 NUT	1	MILD STEEL

ALL DIMENSIONS ARE IN MILLIMETRES	DRAWN: CAREN
	DATE: 26/05/01
ALL UNSPECIFIED RADII ARE R3	CHECKED: PHILIMON
	DATE: 27/05/01
DRAWING PROGRAM: AUTOCAD 2007	APPROVED: SAREL
	DATE: 31/05/01
	SCALE: 1:2

TSIMBI
CORPORATION

TSHEDZA STREET
THOHAYANDOU
0950
www.tsimbi.co.za

TITLE

SPUR GEAR SUB-ASSEMBLY

NATIONAL SENIOR CERTIFICATE
GRADE 12 EXEMPLAR 2008

PAGE 6

ANSWER SHEET 4



ASSESSMENT CRITERIA						
	FACET		SECTIONING		TOTAL	
	POSSIBLE	OBTAINED	POSSIBLE	OBTAINED	POSSIBLE	OBTAINED
1 KEY	2		1		3	
2 SHAFT	10		2½		12½	
3 BUSH	4		2		6	
4 SPUR GEAR	11		4½		15½	
5 HOUSING BRACKET	15½		6		21½	
6 WASHER	1		½		1½	
7 M16-NUT	4½		½		5	
CENTRE LINES					5	
ASSEMBLY					7	
LEFT VIEW					9	
CUTTING PLANE					1	
LABEL VIEW					1	
AUXILIARY VIEW					2	
TOTAL					90	

EXAMINATION NUMBER

EXAMINATION NUMBER

5