



QUESTION 3: ISOMETRIC DRAWING

Given:

- The front view, top view and right view of a SLIDING GUIDE casting
- The position of point P on the drawing sheet

Instructions:

Using scale 1 : 1, convert the orthographic views of the SLIDING GUIDE casting into a sectional isometric drawing on cutting plane A-A.

- Make P the lowest point of the drawing.
- Show ALL construction.
- NO hidden detail is required.

[40]

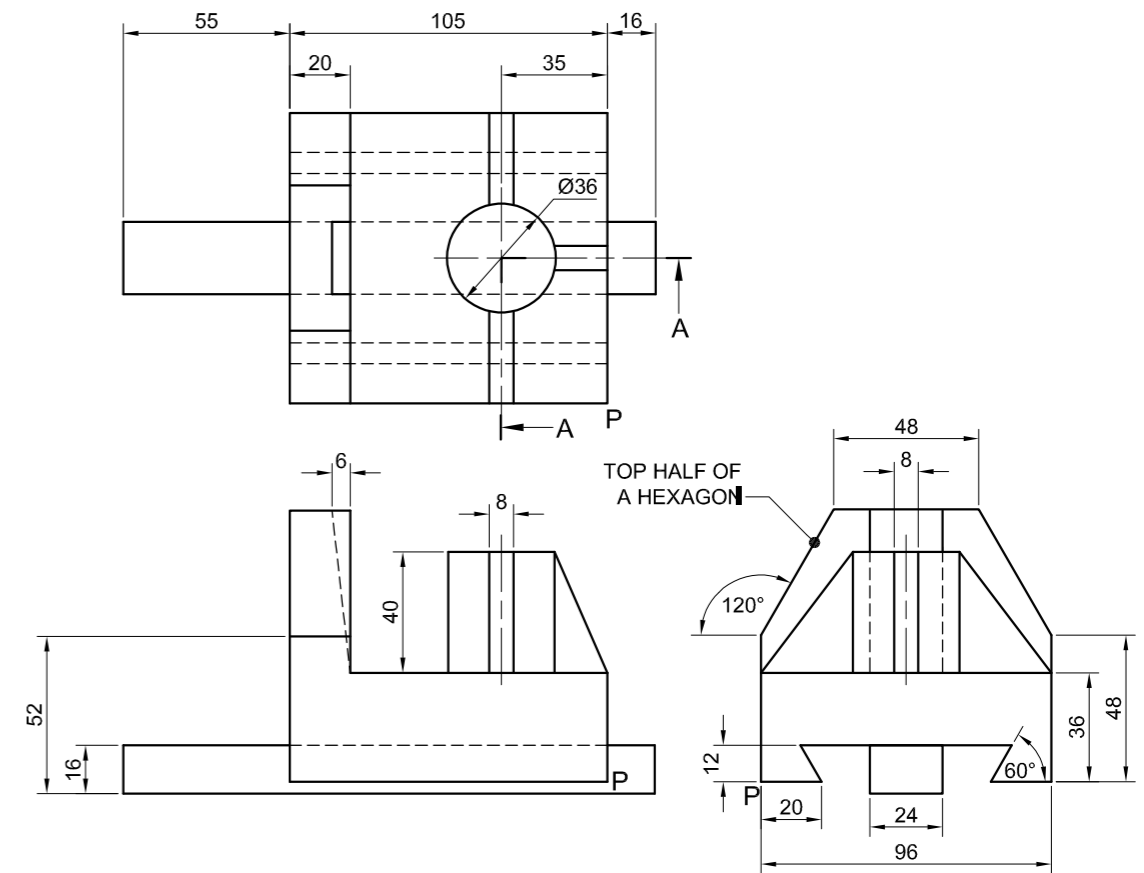

↓
P

ASSESSMENT CRITERIA			
1	PLACING + AUX. VIEWS	2	
2	FRONT + MIDDLE SURFACES	20	
3	SECTIONED SURFACE + HATCHING	12	
4	CIRCLE + CL	6	
PENALTIES (-)			
TOTAL		40	
EXAMINATION NUMBER			
EXAMINATION NUMBER			
			4



QUESTION 3: ISOMETRIC DRAWING

Given:

- The front view and top view of a sliding guide
- The position of point P on the drawing sheet

Instructions:

Using scale 1 : 1, convert the orthographic views of the sliding guide into an isometric drawing.

- Use P as the starting and lowest point of the drawing.
- Show ALL construction.
- NO hidden detail is required. [38]

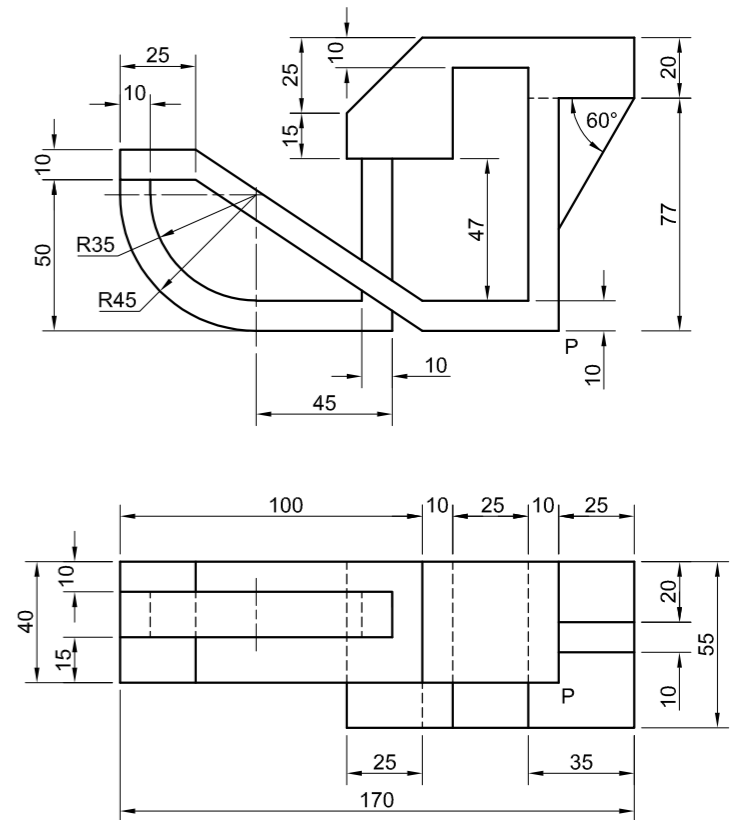

ASSESSMENT CRITERIA			
1	PLACING + AUX. VIEW	1 1/2	
2	BASE	18 1/2	
3	WEB	2 1/2	
4	CIRCLE + CENTRE LINES + BRACE	15 1/2	
PENALTIES (-)			
TOTAL		38	
EXAMINATION NUMBER			
EXAMINATION NUMBER			
			4



QUESTION 3: ISOMETRIC DRAWING

Given:

- The front view, top view and left view of a tool
- The position of point A on the drawing sheet

Instructions:

Using scale 1 : 1, convert the orthographic views of the tool into an isometric drawing.

- Make A the starting and lowest point of the drawing.
- Show ALL construction.
- NO hidden detail is required. **[40]**

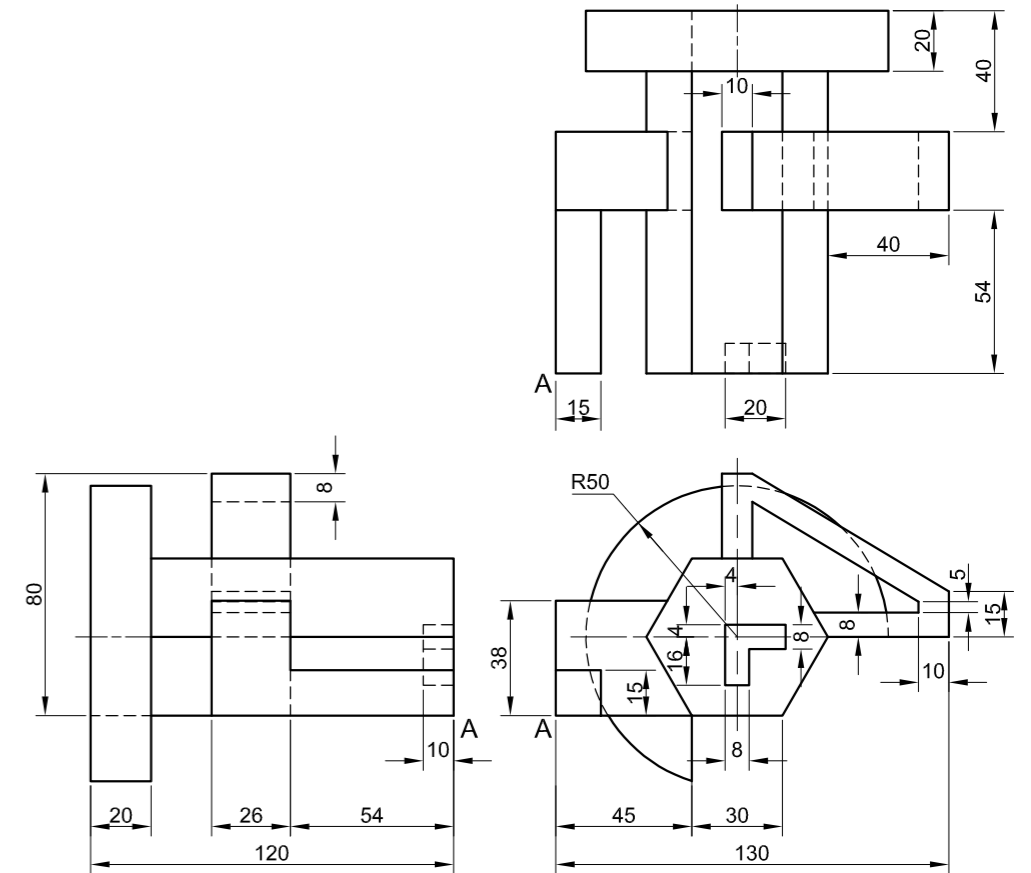

↓
A

ASSESSMENT CRITERIA			
1	PLACING + AUX. VIEW	2	
2	BODY	20	
3	HANDLE	9 1/2	
4	CIRCLES + CONSTR. + CL	8 1/2	
PENALTIES (-)			
TOTAL		40	
EXAMINATION NUMBER			
EXAMINATION NUMBER			4



QUESTION 3: ISOMETRIC DRAWING

Given:

- The front view, top view and left view of a gauge
- The position of point P on the drawing sheet

Instructions:

Using scale 1 : 1, convert the orthographic views of the gauge into an isometric drawing.

- Use P as the starting point for the drawing.
- Show ALL construction.
- NO hidden detail is required. **[39]**

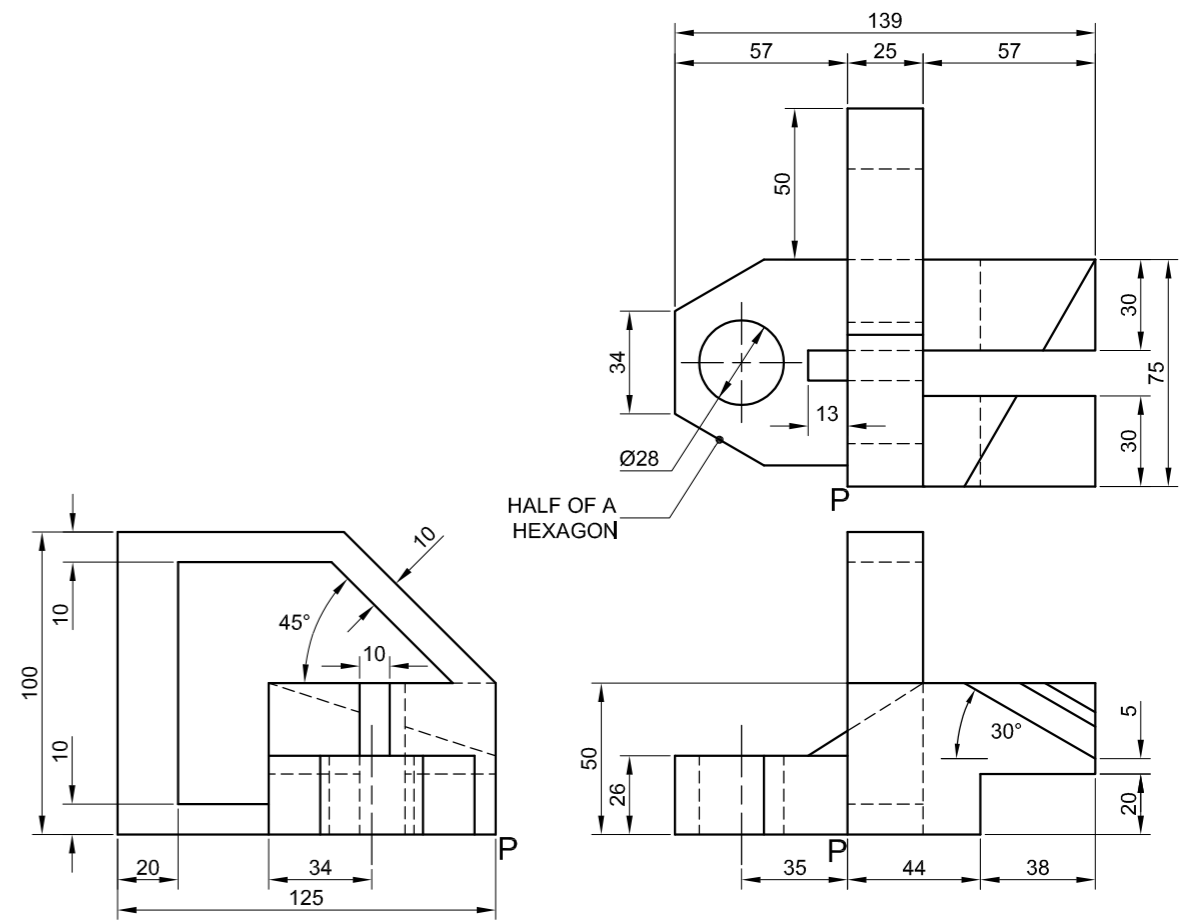

ASSESSMENT CRITERIA				
1	PLACING + AUX VIEWS	4		
2	LEFT PART	17		
3	MIDDLE PART	7 1/2		
4	RIGHT PART	5		
5	CIRCLE + CENTRE LINES + CONSTR'	5 1/2		
PENALTIES (+)				
TOTAL		39		
EXAMINATION NUMBER				
EXAMINATION NUMBER				
				4



QUESTION 3: ISOMETRIC DRAWING

Given:

- The front view, top view and left view of a gauge
- The position of point A on the drawing sheet

Instructions:

Using scale 1 : 1, convert the orthographic views of the gauge into an isometric drawing.

- Make A the lowest point of the drawing.
- Show ALL construction.
- NO hidden detail is required. **[40]**

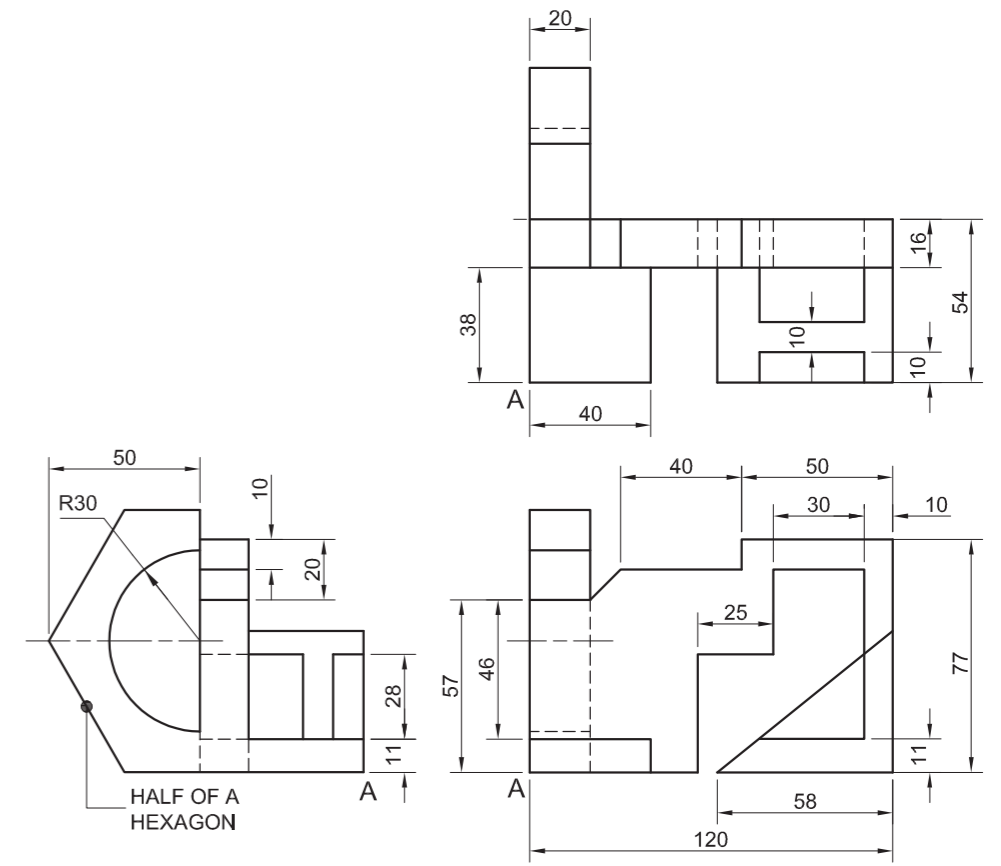

↓
A

ASSESSMENT CRITERIA			
1	PLACING + AUX. VIEW	2	
2	FRONT + MIDDLE SURFACES	16 1/2	
3	SLOPED SURFACE	11	
4	CIRCLE + HEXAGON	10 1/2	
PENALTIES (-)			
TOTAL		40	
EXAMINATION NUMBER			
EXAMINATION NUMBER			
			4





QUESTION 3: ISOMETRIC DRAWING

Given:

- The front view, top view and right view of a groove block and slider assembly
- The position of point S on the drawing sheet

Instructions:

Using scale 1 : 1, convert the orthographic views of the groove block and slider assembly into a sectional isometric drawing on cutting plane A-A.

- Make S the lowest point of the drawing.
- Show ALL construction.
- NO hidden detail is required.

[42]

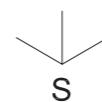
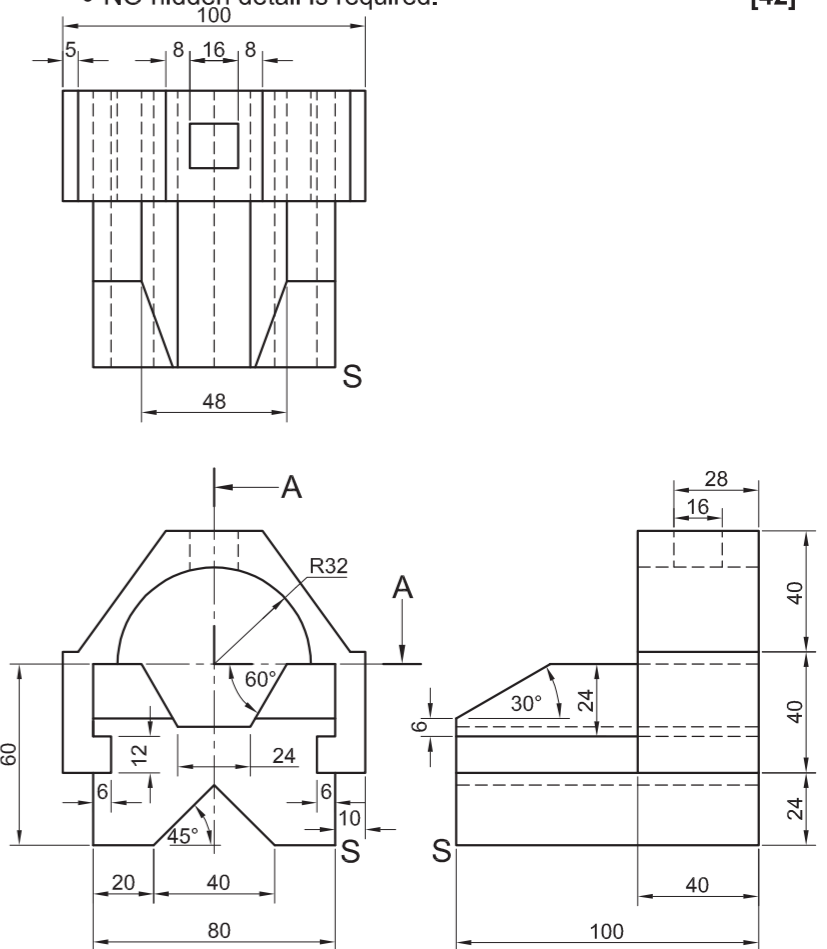

ASSESSMENT CRITERIA			
1	AUX. VIEW + PLACING	2	
2	LOWER PORTION	15	
3	UPPER PORTION	14	
4	SECTION	8	
5	ISO CIRCLES + CIRCLE CONSTR' + CENTRE LINES	3	
PENALTIES			
TOTAL		42	
EXAMINATION NUMBER			
EXAMINATION NUMBER			4





QUESTION 3: ISOMETRIC DRAWING

Given:

- The front view, top view and left view of a jig
- The position of point S on the drawing sheet

Instructions:

Using scale 1 : 1, convert the orthographic views of the jig into a sectional isometric drawing on cutting plane R-R.

- Make S the lowest point of the drawing.
- Show ALL construction.
- NO hidden detail is required.

[40]

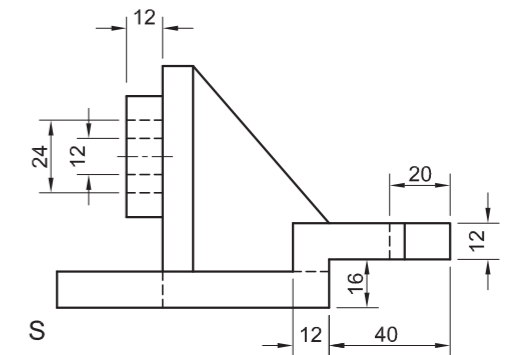
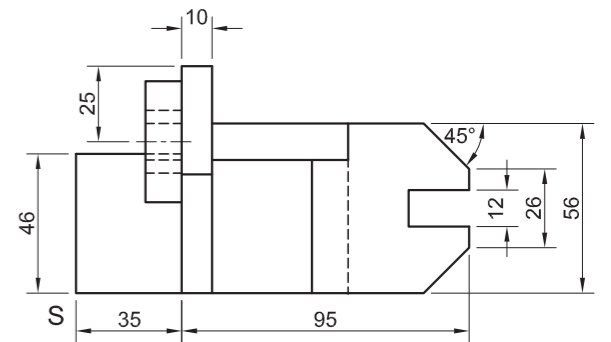
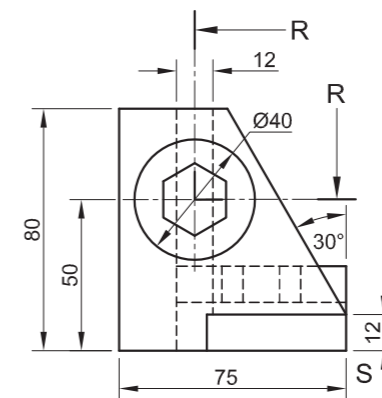

S ↓

ASSESSMENT CRITERIA				
1	PLACEMENT + AUX VIEW	3		
2	BASE	13		
3	UPRIGHT	4½		
4	CIRCLE + HEZAGON	9½		
5	SECTION	10		
PENALTIES (-)				
TOTAL		40		
EXAMINATION NUMBER				
EXAMINATION NUMBER				4





QUESTION 3: ISOMETRIC DRAWING

Given:

- The front view, top view and left view of a tool jig
- The position of point P on the drawing sheet

Instructions:

Using scale 1 : 1, convert the orthographic views of the tool jig into an isometric drawing.

- Make P the lowest point of the drawing.
- Show ALL construction.
- NO hidden detail is required.

[41]

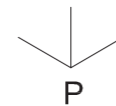
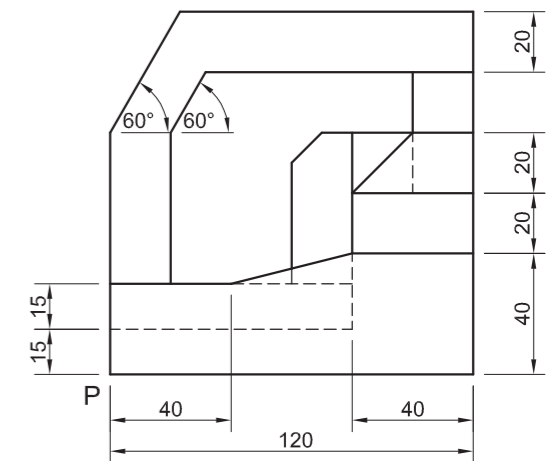
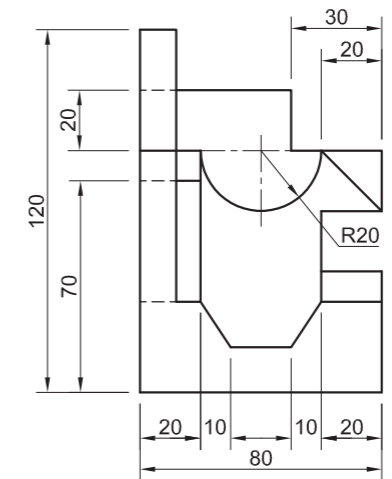
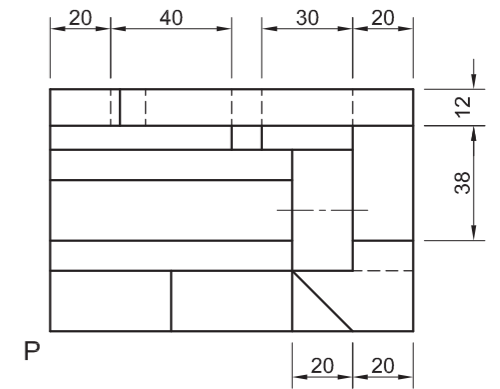

ASSESSMENT CRITERIA			
1	PLACEMENT + AUX. VIEW	3	
2	FRONT PORTION	11	
3	BACK PORTION	21 1/2	
4	CIRCLE + CIRCLE CONSTRUCTION + CL	5 1/2	
PENALTIES (-)			
TOTAL		41	
EXAMINATION NUMBER			
EXAMINATION NUMBER			4





QUESTION 3: ISOMETRIC DRAWING

Given:

- The front view, top view and left view of a punch guide with a regular pentagonal hole
- The position of point P on the drawing sheet

Instructions:

Using scale 1 : 1, convert the orthographic views of the punch guide into a sectional isometric drawing on cutting plane A-A.

- Make P the lowest point of the drawing.
- Show ALL construction.
- NO hidden detail is required.

[38]

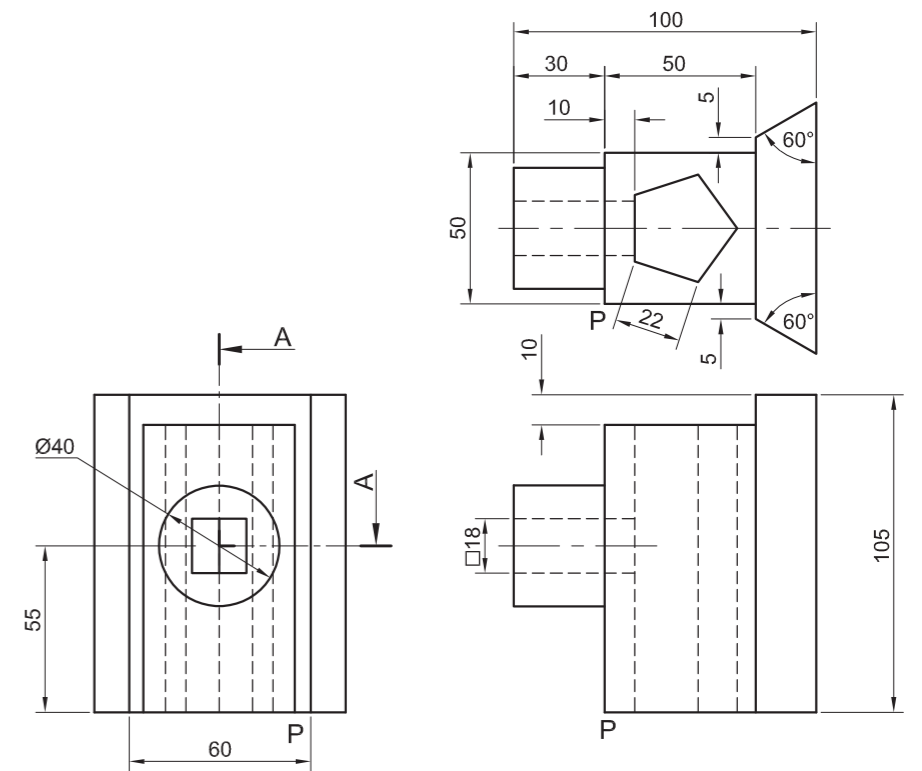

P ↙

ASSESSMENT CRITERIA			
1	AUX. VIEW + PLACING	3	
2	ISOMETRIC + NON-ISO' LINES	14	
3	ISOMETRIC CIRCLES + CIRCLE CONSTR'	7	
4	SECTIONED SURFACES + HATCHING	14	
PENALTIES			
TOTAL		38	
EXAMINATION NUMBER			
EXAMINATION NUMBER			
			4





QUESTION 3: ISOMETRIC DRAWING

Given:

- The front view, top view and left view of a bracket
- The position of point S on the drawing sheet

Instructions:

Using scale 1 : 1, convert the orthographic views of the bracket into an isometric drawing.

- Make S the lowest point of the drawing.
- Show ALL construction.
- NO hidden detail is required.

[38]

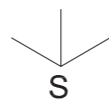
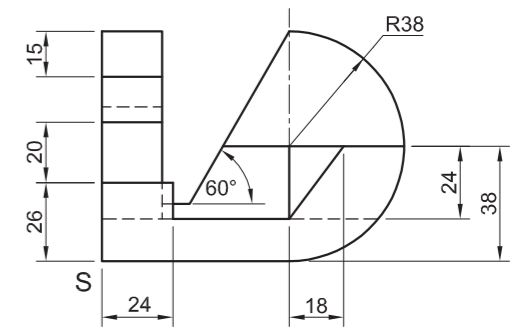
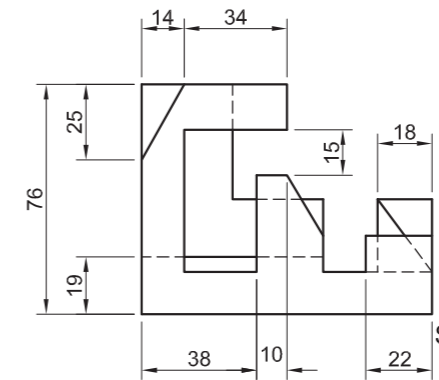
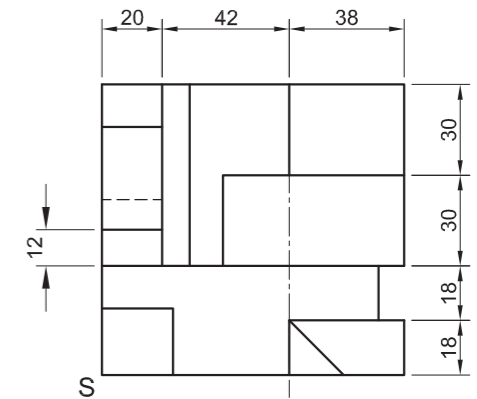

ASSESSMENT CRITERIA			
1	PLACEMENT + AUX. VIEW	2	
2	FRONT PORTION	23½	
3	BACK PORTION	5	
4	CIRCLE + CIRCLE CONSTRUCTION + CL	7½	
PENALTIES (-)			
TOTAL		38	
EXAMINATION NUMBER			
EXAMINATION NUMBER			4





QUESTION 3: ISOMETRIC DRAWING

Given:

- The front view, top view and left view of a jig
- The position of point B on the drawing sheet

Instructions:

Using scale 1 : 1, convert the orthographic views of the jig into an isometric drawing.

- Make B the lowest point of the drawing.
- Show ALL construction.
- NO hidden detail is required.

[41]

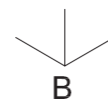
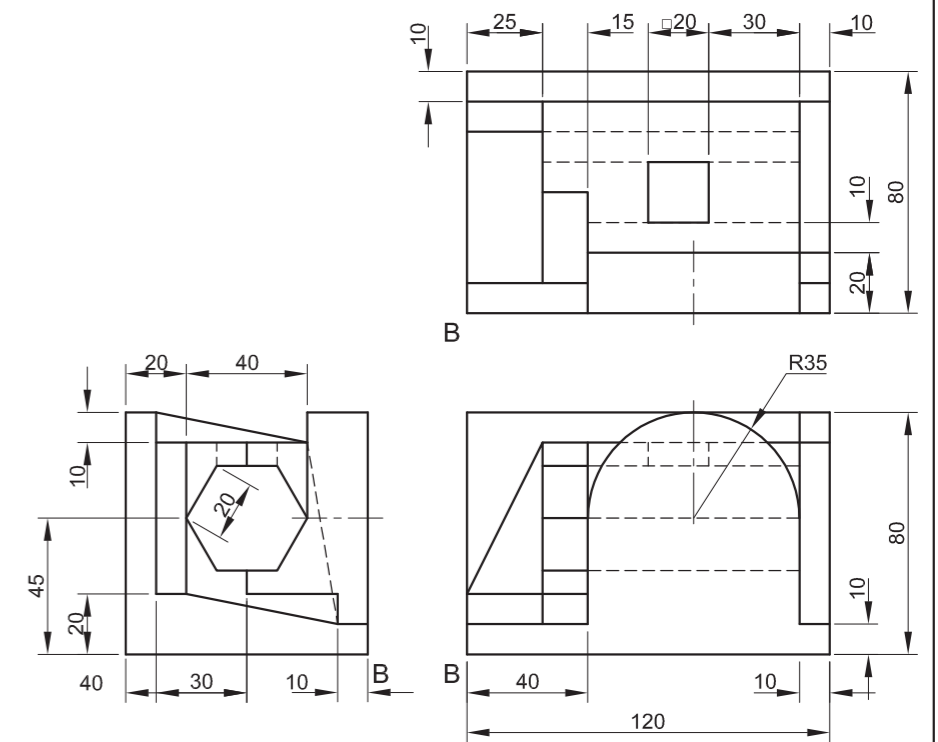

ASSESSMENT CRITERIA			
1	PLACEMENT + AUX. VIEW	2	
2	ISOMETRIC + NON ISOMETRIC LINES	24 1/2	
3	HEXAGON + SQUARE	10	
4	CIRCLE + CIRCLE CONSTRUCTION + CL	4 1/2	
PENALTIES (-)			
TOTAL		41	
EXAMINATION NUMBER			
EXAMINATION NUMBER			4





QUESTION 3: ISOMETRIC DRAWING

Given:

- The front view, top view and left view of a guide
- The position of point B on the drawing sheet

Instructions:

Using scale 1 : 1, convert the orthographic views of the guide into an isometric drawing.

- Make B the lowest point of the drawing.
- Show ALL construction.
- NO hidden detail is required.

[36]

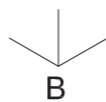
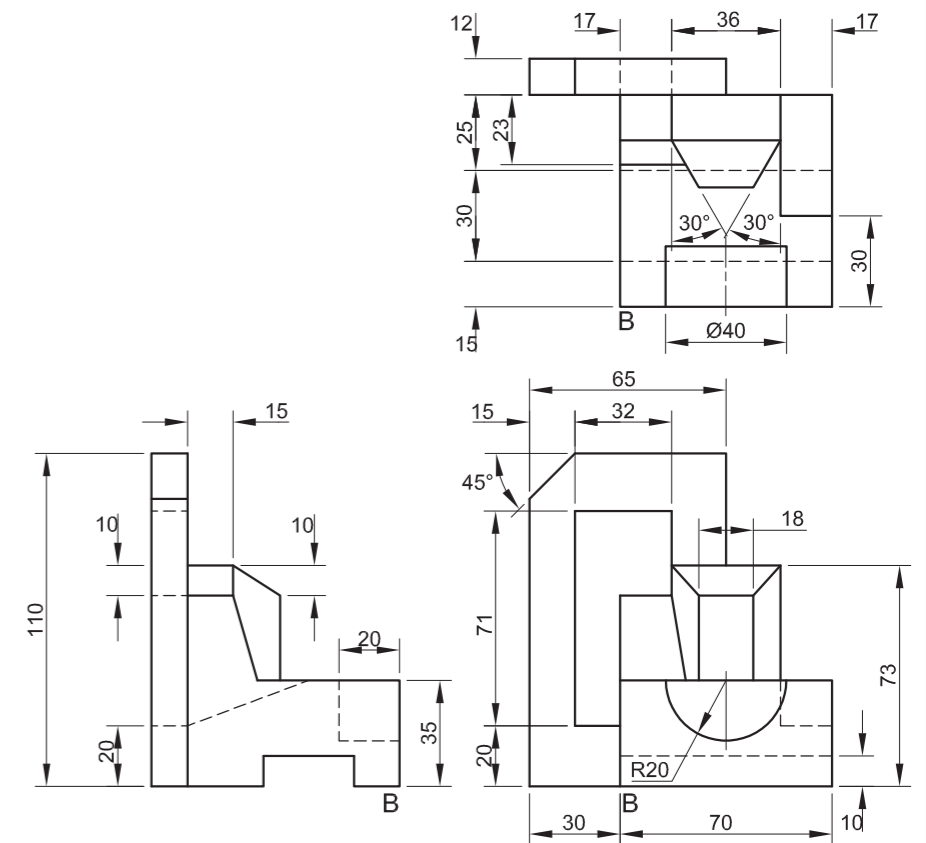

ASSESSMENT CRITERIA			
1	PLACEMENT + AUX. VIEW	2	
2	FRONT + REAR	18	
3	MIDDLE SECTION	10	
4	CIRCLE + CIRCLE CONSTRUCTION + CL	6	
PENALTIES (-)			
TOTAL		36	
EXAMINATION NUMBER			
EXAMINATION NUMBER			4





QUESTION 3: ISOMETRIC DRAWING

Given:

- The front view, top view and left view of a toy
- The position of point P on the drawing sheet

Instructions:

Using scale 1 : 1, convert the orthographic views of the toy to an isometric drawing.

- Make P the lowest point of the drawing.
- Show ALL construction.
- NO hidden detail is required.

[44]

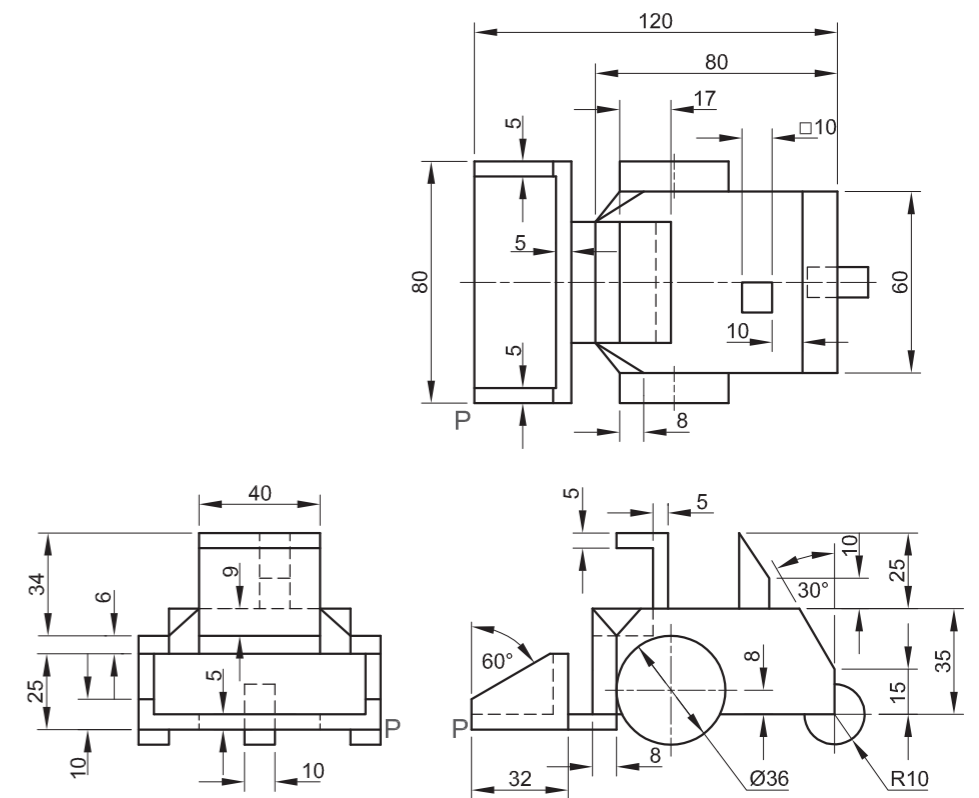

ASSESSMENT CRITERIA			
1	PLACEMENT + AUX VIEW	2	
2	SCOOP + BODY	22	
3	CABIN + EXHAUST	11 1/2	
4	CIRCLE + CIRCLE CONSTRUCTION + CL	8 1/2	
TOTAL		44	
EXAMINATION NUMBER			
EXAMINATION NUMBER			4





QUESTION 3: ISOMETRIC DRAWING

Given:

- The front view and top view of a bracket
- The position of point S on the drawing sheet

Instructions:

Using scale 1 : 1, convert the orthographic views of the bracket to an isometric drawing.

- Make S the lowest point of the drawing.
- Show ALL construction.
- NO hidden detail is required.

[39]

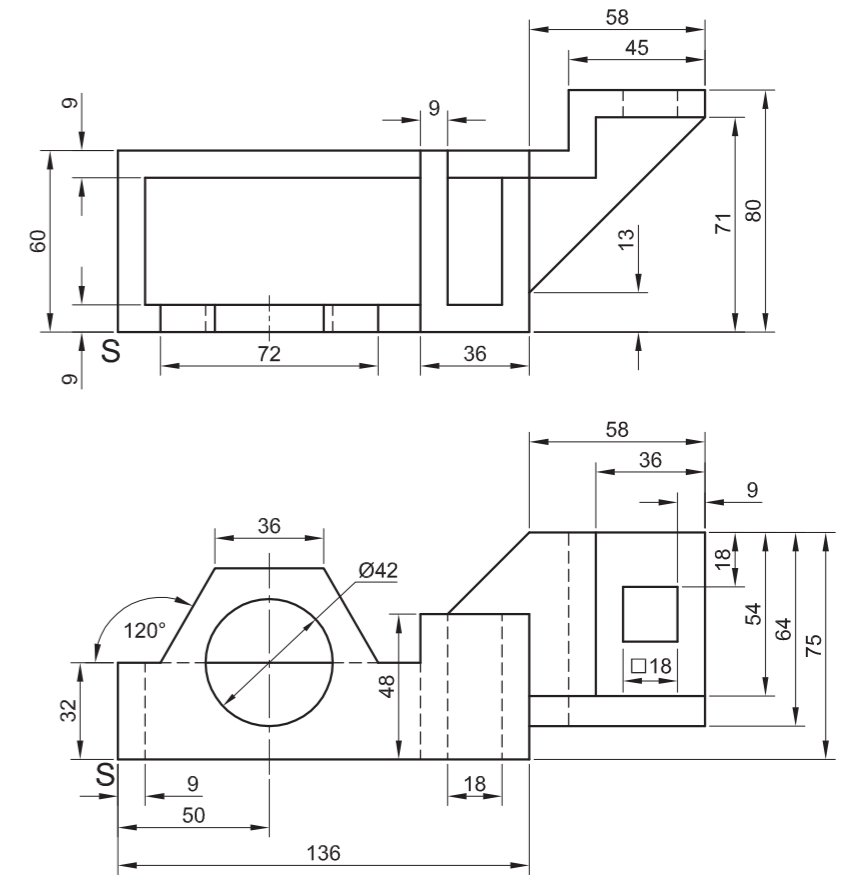

S

ASSESSMENT CRITERIA			
1	AUXILIARY VIEW + PLACEMENT	2	
2	FRONT + REAR SECTION	25	
3	HEXAGON	4	
4	CIRCLE + CL	8	
PENALTIES (-)			
TOTAL		39	
EXAMINATION NUMBER			
EXAMINATION NUMBER			4





QUESTION 3: ISOMETRIC DRAWING

Given:

- The front view, top view and left view of a jig
- The position of point S on the drawing sheet

Instructions:

Using scale 1 : 1, convert the orthographic views of the jig into a sectional isometric drawing on cutting plane A-A.

- Make S the lowest point of the drawing.
- Show ALL necessary construction.
- NO hidden detail is required.

[40]

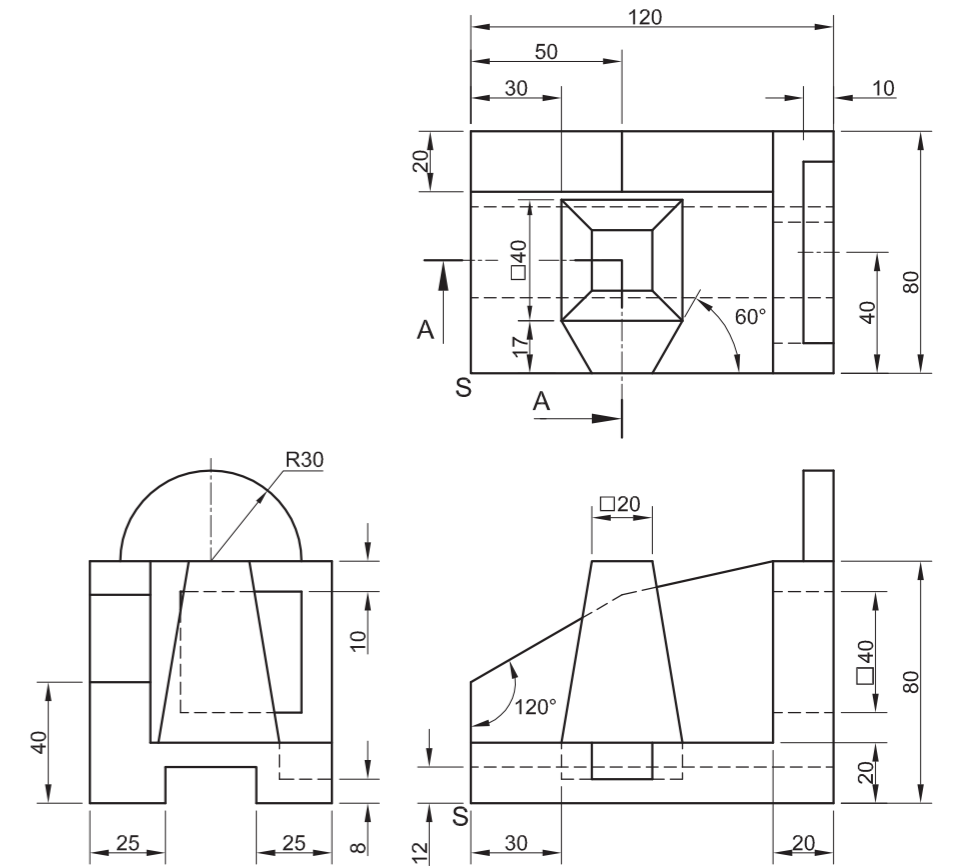

S ↙

ASSESSMENT CRITERIA			
1	AUX. VIEW + PLACING	2 1/2	
2	ISOMETRIC + NON-ISOMETRIC LINES	23	
3	SECTIONED SURFACES	9	
4	ISOMETRIC CIRCLES + CIRCLE CONSTR'	5 1/2	
TOTAL		40	
EXAMINATION NUMBER			
EXAMINATION NUMBER			
EXAMINATION NUMBER			4





QUESTION 3: ISOMETRIC DRAWING

Given:

- The front view, top view and right view of a toy planter
- The position of corner L on the drawing sheet

Instructions:

Using scale 1 : 1, convert the orthographic views of the toy planter into an isometric drawing.

- Use corner L as the starting point of the drawing.
- Show ALL necessary construction.
- NO hidden detail is required.

[40]

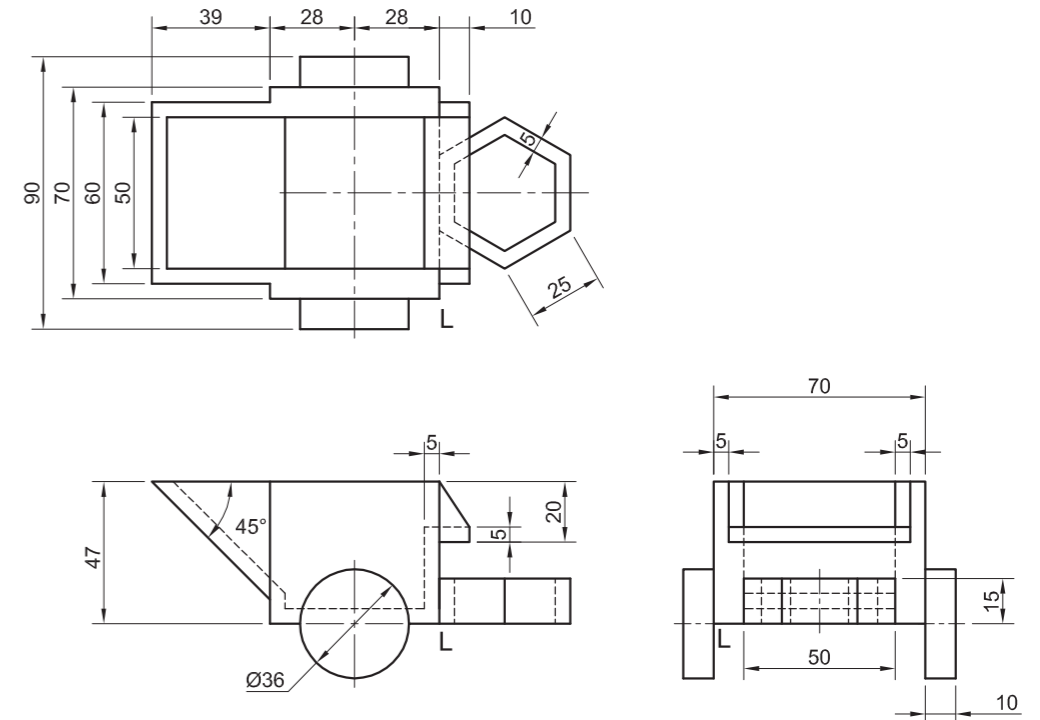

ASSESSMENT CRITERIA				
1	AUXILIARY VIEWS + PLACING	2		
2	ISOMETRIC + NON-ISOMETRIC LINES	18 1/2		
3	HEXAGON	12		
4	CIRCLES + CONSTRUCTION + CENTRE LINES	7 1/2		
PENALTIES (-)				
TOTAL		40		
EXAMINATION NUMBER				
EXAMINATION NUMBER				4





QUESTION 3: ISOMETRIC DRAWING

Given:

- The front view, top view and left view of a woodworking plane
- The position of point P on the drawing sheet

Instructions:

Using scale 1 : 1, convert the orthographic views of the woodworking plane into a sectional isometric drawing on cutting plane A-A.

- Make P the lowest point of the drawing.
- Show ALL necessary construction.
- NO hidden detail is required.

[34]

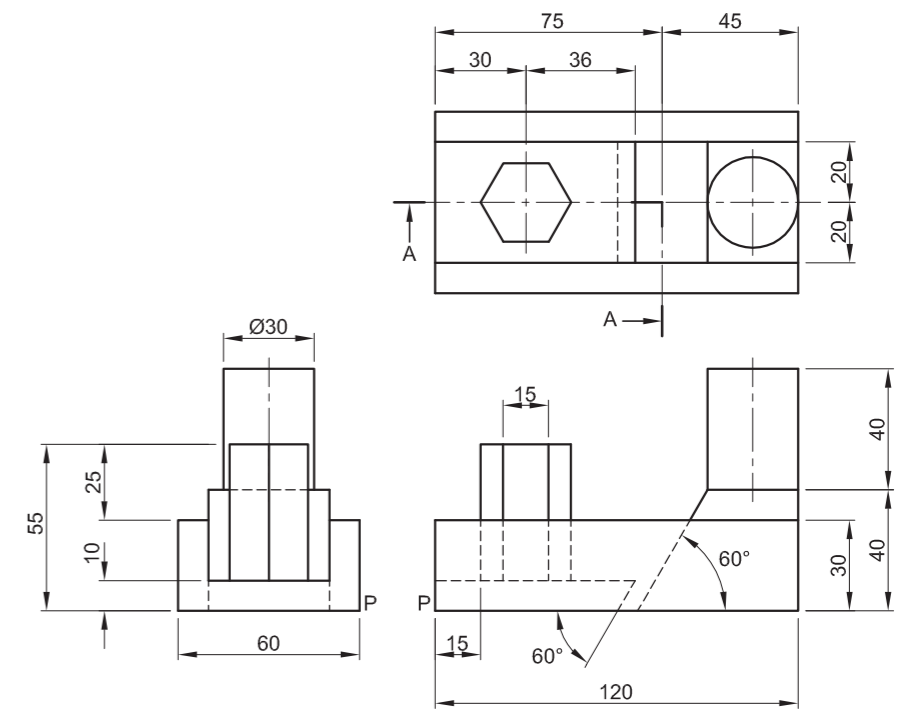

↓
P

ASSESSMENT CRITERIA					
1	AUXILIARY VIEW + PLACING	3			
2	ISOMETRIC + NON-ISOMETRIC	12 1/2			
3	HEXAGON	2 1/2			
4	CIRCLES + CONSTRUCTION + CL	6			
5	SECTION	8			
6	HATCHING	2			
PENALTIES (-)					
TOTAL		34			
EXAMINATION NUMBER					
					4





QUESTION 3: ISOMETRIC DRAWING

Given:

- The front view, top view and left view of a machine switch with cutting plane A-A
- The position of point P on the drawing sheet

Instructions:

Using scale 1 : 1, convert the orthographic views of the machine switch into a sectional isometric drawing on cutting plane A-A.

- Make P the lowest point of the drawing.
- Show ALL necessary construction.
- NO hidden detail is required.

[39]

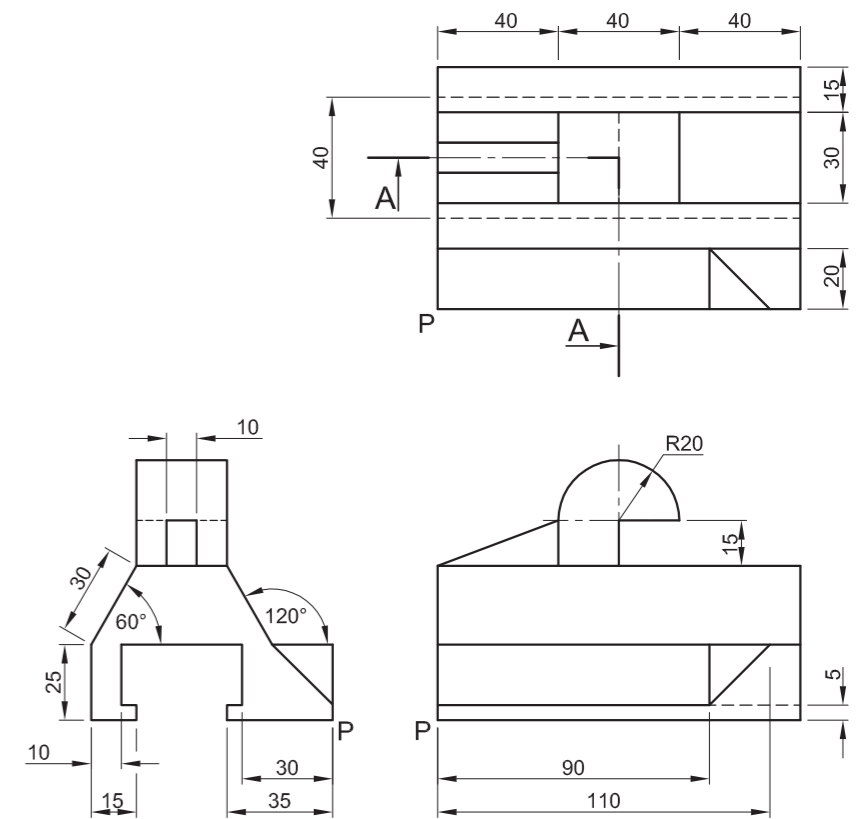

P ↙

ASSESSMENT CRITERIA				
1	AUX. VIEW + PLACING	3		
2	ISOMETRIC + NON-ISOMETRIC LINES	16½		
3	ISO' CIRCLES + CIRCLE CONSTRUCTION	5		
4	SECTIONED SURFACES	11		
5	HATCHING	3½		
PENALTIES (-)				
TOTAL		39		
EXAMINATION NUMBER				
EXAMINATION NUMBER				
EXAMINATION NUMBER				4





QUESTION 3: ISOMETRIC DRAWING

Given:

- The front view, top view and right view of a bracket
- The position of point P on the drawing sheet

Instructions:

Using scale 1 : 1, convert the orthographic views of the bracket into a sectional isometric drawing on cutting plane S-S.

- Make P the lowest point of the drawing.
- Show ALL necessary construction.
- NO hidden detail is required.

[37]

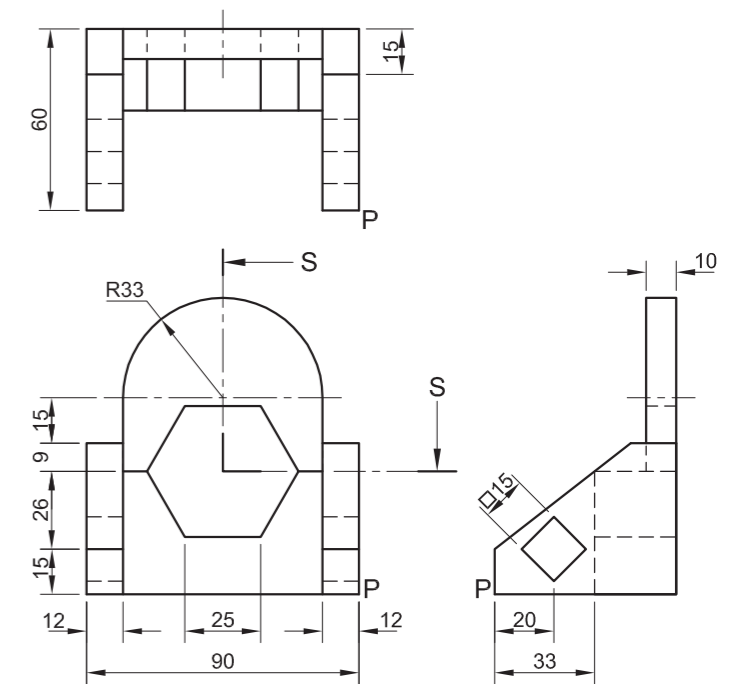

↓
P

ASSESSMENT CRITERIA			
1	AUX. VIEW + PLACING	3	
2	ISOMETRIC + NON-ISO'	13	
3	HEXAGON + SQUARES	9½	
4	CIRCLES + CONST.	4	
5	SECTION	5	
6	HATCHING	2½	
PENALTIES (-)			
TOTAL		37	
EXAMINATION NUMBER			
EXAMINATION NUMBER			4





QUESTION 3: ISOMETRIC DRAWING

Given:

- The front view, top view and left view of a support
- The position of point P on the drawing sheet

Instructions:

Using scale 1 : 1, convert the orthographic views of the support into a sectional isometric drawing on cutting plane A-A.

- Make P the lowest point of the drawing.
- Show ALL necessary construction.
- NO hidden detail is required.

[36]

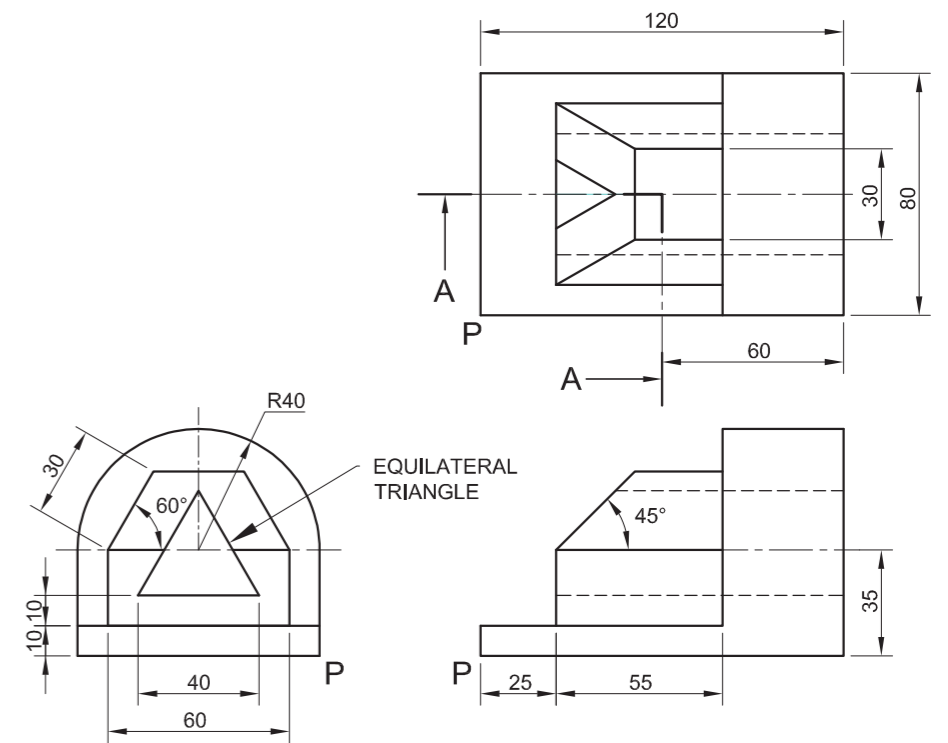

P ↙

ASSESSMENT CRITERIA			
1.	AUX. VIEW + PLACING	4	
2.	ISOMETRIC + NON-ISOMETRIC LINES	13	
3.	ISOMETRIC CIRCLES	4	
4.	CIRCLE CONSTRUCTION	2	
5.	SECTIONED SURFACES	9	
6.	HATCHING	4	
TOTAL		36	
EXAMINATION NUMBER			
EXAMINATION NUMBER			4



QUESTION 3: ISOMETRIC DRAWING

Given:

- The front view and top view of a jig
- The position of point S on the drawing sheet

Instructions:

Using scale 1 : 1, convert the orthographic views of the jig to an isometric drawing.

- Make S the lowest point of the drawing.
- Show ALL necessary construction.
- NO stencils may be used.
- NO hidden detail is required.

[41]

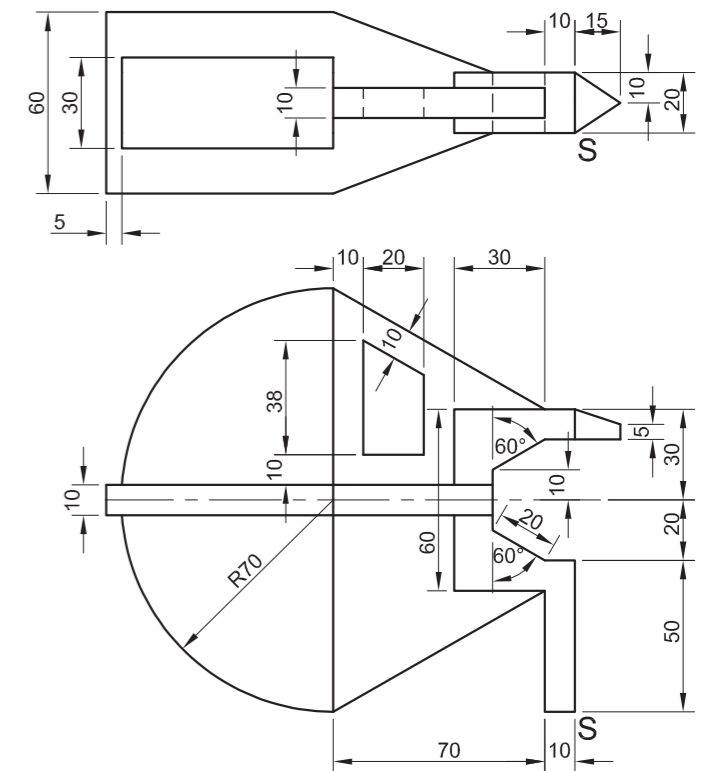

S

ASSESSMENT CRITERIA			
1	AUX. + PLACEMENT	2	
2	FRONT	19	
3	MIDDLE	14	
4	CONSTR. + CIRCLE	6	
TOTAL		41	
EXAMINATION NUMBER			
EXAMINATION NUMBER			
EXAMINATION NUMBER			4





QUESTION 3: ISOMETRIC DRAWING

Given:

- The front view, top view and left view of a bracket
- The position of point S on the drawing sheet

Instructions:

Using scale 1 : 1, convert the orthographic views of the bracket to a sectional isometric drawing on cutting plane A-A.

- Make S the lowest point of the drawing.
- Show ALL necessary construction.
- NO stencils may be used.
- NO hidden detail is required.

[41]

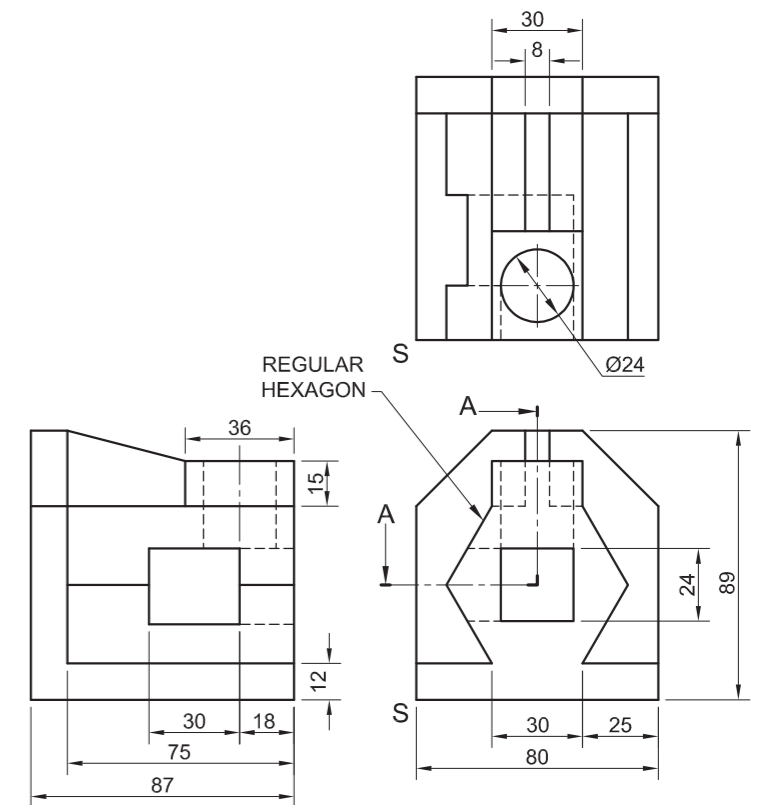

S ↙

ASSESSMENT CRITERIA			
1	AUX' VIEW + PLACEMENT	2	
2	BASE	8	
3	HEXAGONAL PRISM	10	
4	CIRCLES	5	
5	SECTION	12	
6	HATCHING	4	
TOTAL		41	
EXAMINATION NUMBER			
EXAMINATION NUMBER			
			4





QUESTION 3: ISOMETRIC DRAWING

Given:

- The front view, top view and right view of a bracket with a regular pentagonal hole
- The position of point A on the drawing sheet

Instructions:

Using scale 1 : 1, convert the orthographic views of the bracket into an isometric drawing.

- Make A the lowest point of the drawing.
- Show ALL necessary construction.
- NO stencils may be used.
- NO hidden detail is required.

[37]

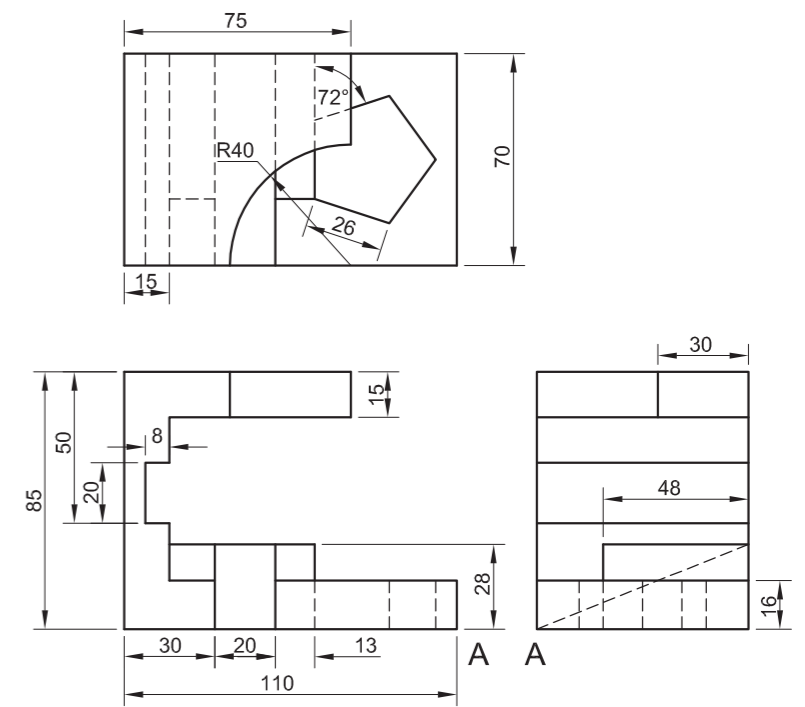

↓
A

ASSESSMENT CRITERIA			
1	AUX' VIEW + CIRCLE PENTAGON + PLACING	12	
2	LOWER PORTION	15½	
3	UPPER PORTION	9½	
TOTAL		37	
EXAMINATION NUMBER			
EXAMINATION NUMBER			
EXAMINATION NUMBER			4





QUESTION 3: ISOMETRIC DRAWING

Given:

- The front view, top view and left view of a bracket with a regular octagonal hole
- The position of point A on the drawing sheet

Instructions:

Using scale 1 : 1, convert the orthographic views of the bracket into an isometric drawing.

- Make A the lowest point of the drawing.
- Show ALL necessary construction.
- NO stencils may be used.
- NO hidden detail is required.

[36]

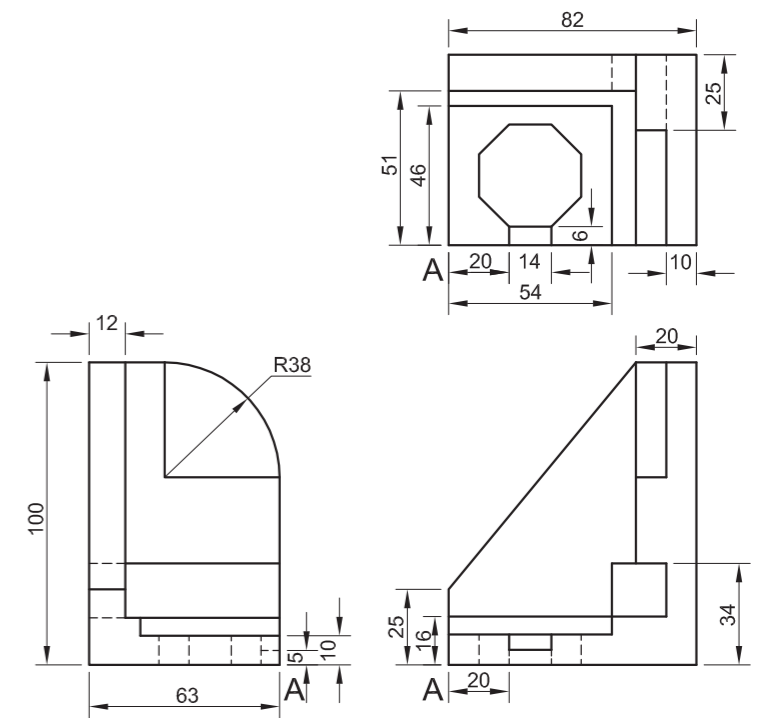

↓
A

ASSESSMENT CRITERIA			
1	AUX' VIEWS + CIRCLE + CONSTR' + PLACE	5	
2	OCTAGONAL HOLE	10	
3	ISO' + NON-ISO' LINES	21	
TOTAL		36	
EXAMINATION NUMBER			
EXAMINATION NUMBER			
EXAMINATION NUMBER			4





QUESTION 3: ISOMETRIC DRAWING

Given:

- The front view, top view and left view of a jig with a regular hexagonal hole
- The position of point A on the drawing sheet

Instructions:

Using scale 1 : 1, convert the orthographic views of the jig into an isometric drawing.

- Make A the lowest point of the drawing.
- Show ALL necessary construction.
- NO stencils may be used.
- NO hidden detail is required.

[39]

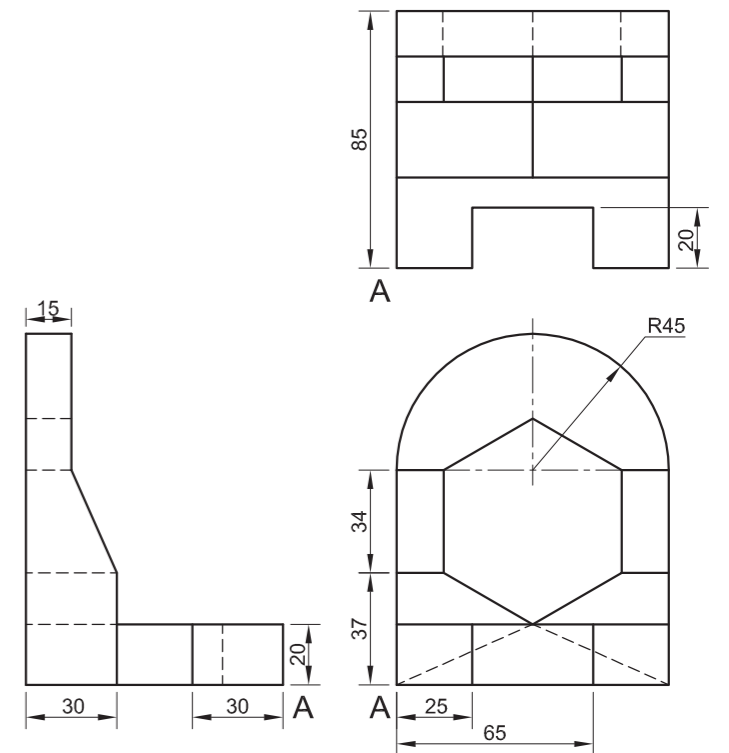

↓
A

ASSESSMENT CRITERIA			
1. AUXILIARY VIEW + PLACEMENT + CIRCLE CONSTRUCTION	5		
2. ISO' CIRCLES + CENTRE LINES	5		
3. ISO + NON-ISO' LINES	18		
4. HEXAGON	11		
TOTAL	39		
EXAMINATION NUMBER			
EXAMINATION NUMBER			
EXAMINATION NUMBER			4



QUESTION 3: ISOMETRIC DRAWING

Given:

- The front view, top view and right view of a safety clip with TWO regular pentagonal slot holes
- The position of point A on the drawing sheet

Instructions:

Using scale 1 : 1, convert the orthographic views of the safety clip into an isometric drawing.

- Make A the lowest point of the drawing.
- Show ALL necessary construction.
- NO stencils may be used.
- NO hidden detail is required.

[40]

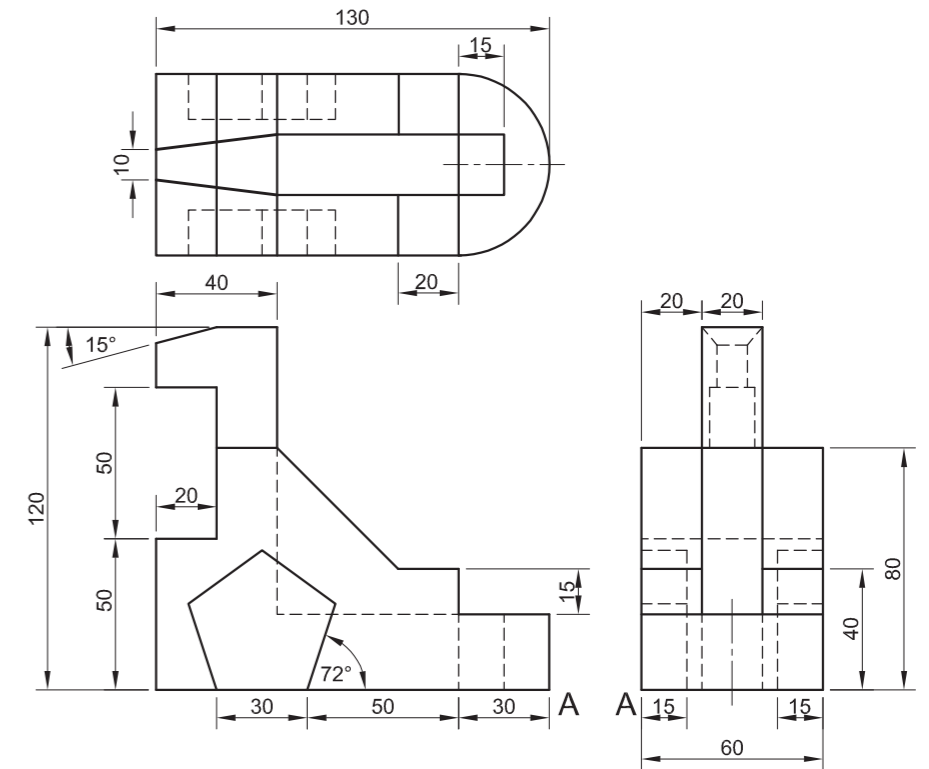

↓
A

ASSESSMENT CRITERIA			
AUXILIARY VIEWS + CIRCLE CONSTRUCTION + PLACE	6		
ISO' ARCS + PENTAGONAL HOLE	11		
ISO' + NON-ISO' LINES	23		
TOTAL	40		
EXAMINATION NUMBER			
EXAMINATION NUMBER			
EXAMINATION NUMBER			4





QUESTION 3: ISOMETRIC DRAWING

Given:

- The front view, top view and left view of a movable coupling
- The position of point A on the drawing sheet

Instructions:

Convert the orthographic views of the movable coupling into a scale 1 : 1 isometric drawing.

- Make corner A the lowest point of the drawing.
- Show ALL necessary circle and other construction.
- NO hidden detail is required. [39]

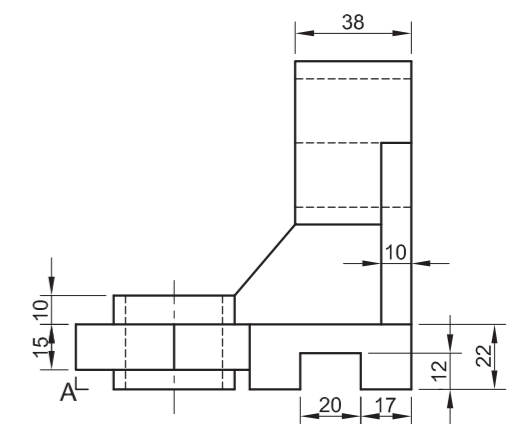
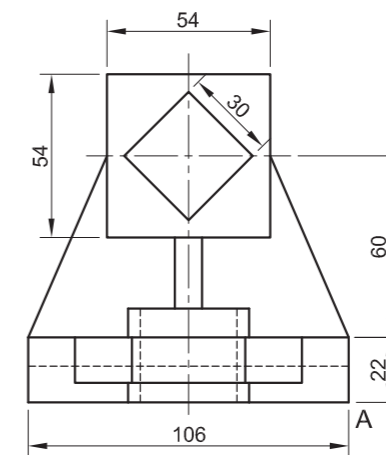
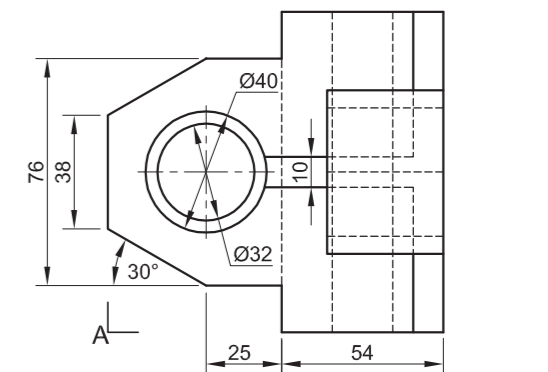

ASSESSMENT CRITERIA			
1. AUX. VIEW + PLACING	4		
2. ISOMETRIC LINES	20		
3. NON-ISOMETRIC LINES	6½		
4. ISOMETRIC CIRCLES	5½		
5. CIRCLE CONSTRUCTION	2		
6. CENTRE LINES	1		
TOTAL	39		
EXAMINATION NUMBER			
EXAMINATION NUMBER			
			4





QUESTION 3: ISOMETRIC DRAWING

Given:

- The front view, top view and left view of a channel drilling jig with cutting plane A-A
- The position of point B on the drawing sheet

Instructions:

Convert the orthographic views of the channel drilling jig into a scale 1 : 1 sectional isometric drawing on cutting plane A-A.

- Make corner B the lowest point of the drawing.
- Show ALL necessary circle and other construction.
- NO hidden detail is required. **[40]**

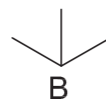
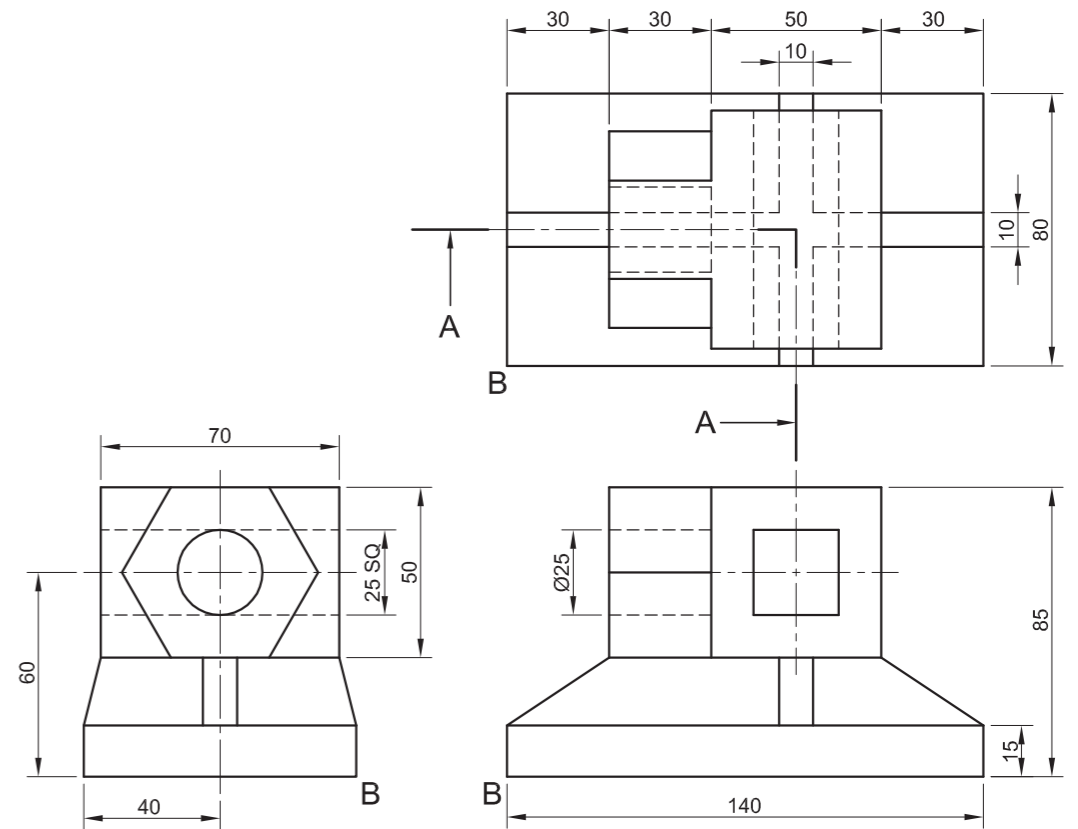

ASSESSMENT CRITERIA			
1. AUX. VIEW + PLACING	3		
2. ISOMETRIC LINES	11		
3. NON-ISOMETRIC LINES	3		
4. ISOMETRIC CIRCLES	3		
5. CIRCLE CONSTRUCTION	1½		
6. CENTRE LINES	1½		
7. SECTIONED SURFACES	13		
8. HATCHING	4		
TOTAL	40		
EXAMINATION NUMBER			
EXAMINATION NUMBER			
EXAMINATION NUMBER			4





QUESTION 3: ISOMETRIC DRAWING

Given:

- The front view, top view and right view of a cross slide with a cutting plane A-A
- The position of point B on the drawing sheet

Instructions:

Convert the orthographic views of the cross slide into a sectional isometric drawing on cutting plane A-A.

- Make corner B the lowest point of the drawing.
- Show ALL necessary circle construction.
- NO hidden detail is required.

[43]

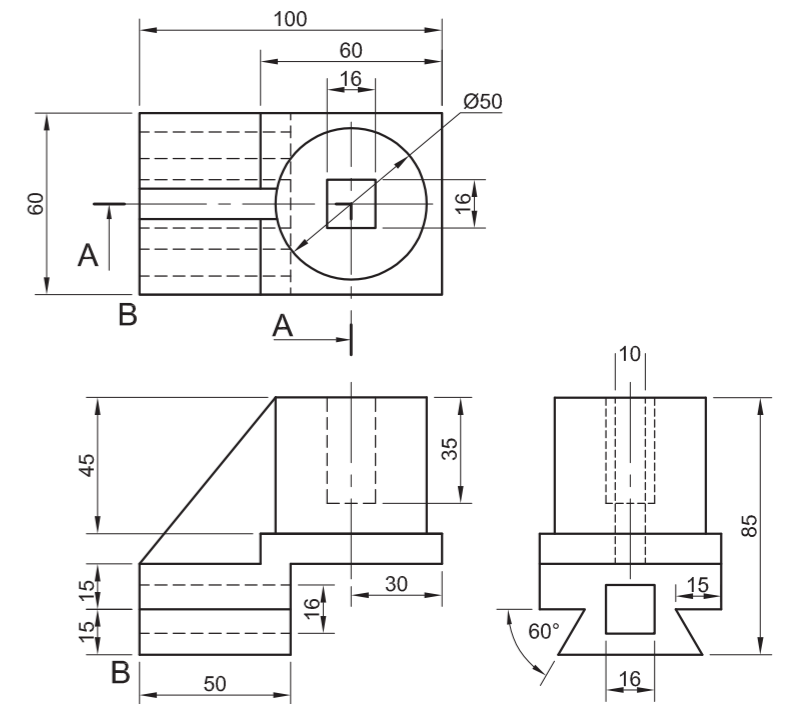

↓
B

ASSESSMENT CRITERIA			
AUXILIARY VIEW + PLACING	3		
ISO' CIRCLES + CONSTR' + CENTRE LINES	9		
ISO' + NON-ISO' LINES	15½		
SECTIONED SURFACES	11½		
HATCHING/NO HATCHING	4		
TOTAL	43		
EXAMINATION NUMBER			
EXAMINATION NUMBER			
EXAMINATION NUMBER			4



QUESTION 3: ISOMETRIC DRAWING

Given:

The front view, top view and right view of a jig bracket with a cutting plane A-A.

The position of point B on the drawing sheet.

Instructions:

Convert the orthographic views of the jig bracket into a sectional isometric drawing on cutting plane A-A.

- Make corner B the lowest point of the drawing.
- Show ALL necessary construction.
- NO hidden detail is required.

[44]

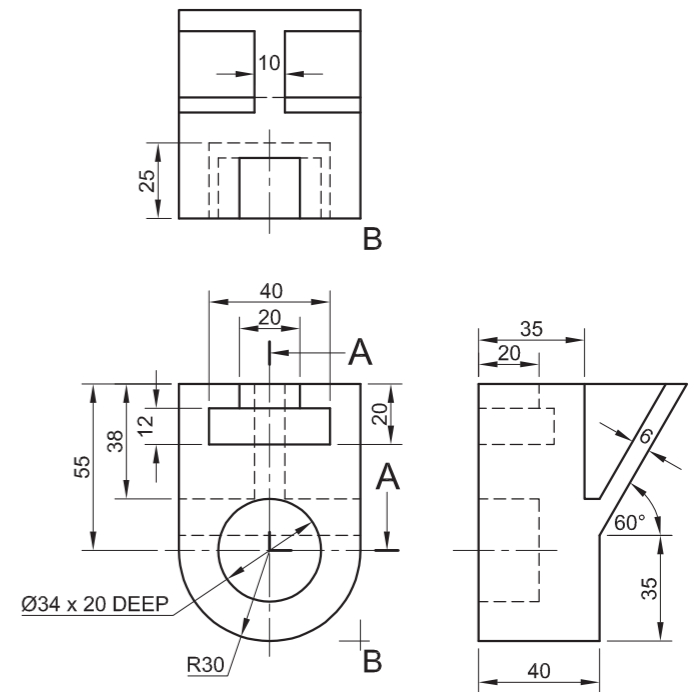

↓
B

ASSESSMENT CRITERIA			
CONSTR' + AUX + B	8		
ISO' CIRCLES + CNTR LINES	8½		
ISO' + NON-ISO' LINES	12		
SECTIONED SURFACES	10½		
HATCHING	5		
TOTAL	44		
EXAMINATION NUMBER			
EXAMINATION NUMBER			
EXAMINATION NUMBER			4



QUESTION 3: ISOMETRIC DRAWING

Given:

The front view and left view of a pipe support.
The position of point A on the drawing sheet.

Instructions:

3. Convert the orthographic views of the pipe support into an isometric drawing.

- Make corner A the lowest point of the drawing.
- Show ALL necessary construction.
- NO hidden detail is required.

[43]

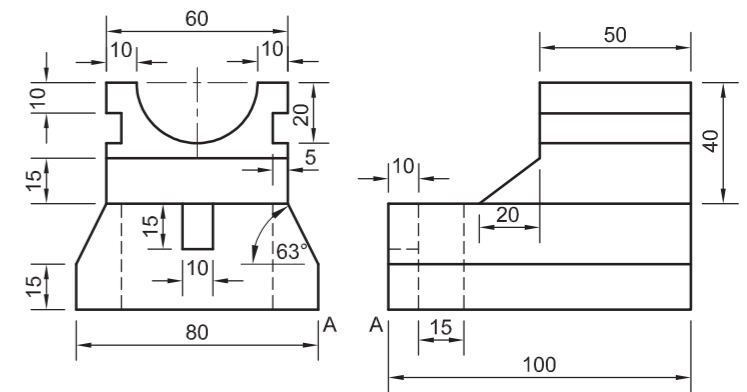

↓
A

ASSESSMENT CRITERIA

AUXILIARY VIEW	=	2
ISOMETRIC LINES	=	26
NON-ISOMETRIC LINES	=	5
ISOMETRIC CIRCLES	=	3
CIRCLE CONSTRUCTION	=	3
CENTRE LINES	=	3
PLACING ON A	=	1
TOTAL	=	43

EXAMINATION NUMBER	
EXAMINATION NUMBER	4



QUESTION 3: ISOMETRIC DRAWING

Given:

The front view and top view of a hexagonal slide plate that is cut by cutting plane B-B.

Instructions:

- Convert the orthographic views of the hexagonal slide plate into a sectional isometric drawing on B-B.
- Make corner A the lowest point of the drawing so that the sectioned surfaces are visible.
- Show ALL necessary construction.
- NO hidden detail is required.

[40]

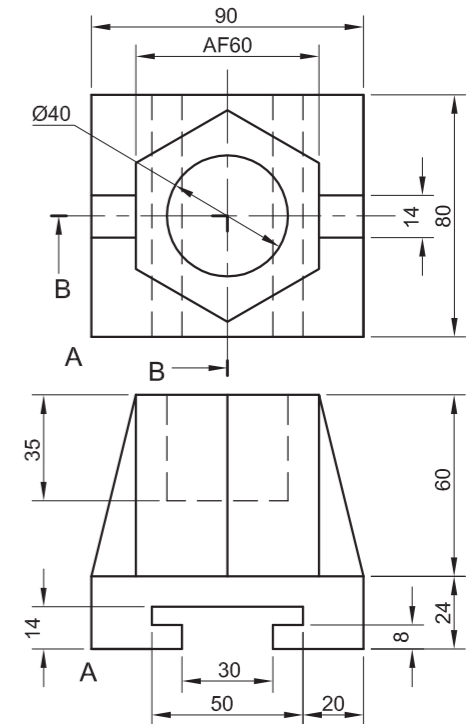

ASSESSMENT CRITERIA

AUXILIARY VIEW	= 2
ISOMETRIC SURFACES	= 6
NON-ISOMETRIC LINES	= 2
SECTIONED SURFACE	= 9½
ISOMETRIC CIRCLES	= 4
CIRCLE CONSTRUCTION	= 3
HATCHING	= 4
CENTRE LINES	= 2½
HEXAGON	= 5
PLACING ON A	= 2
TOTAL	= 40

EXAMINATION NUMBER	
EXAMINATION NUMBER	4



QUESTION 3: ISOMETRIC DRAWING

Given:

The front view and top view of a rod guide that is cut by cutting plane A-A.

Instructions:

- Convert the orthographic views of the rod guide into a sectional isometric drawing.
- Position the answer so that the sectioned surfaces are visible.
- Show the circle construction.
- NO hidden detail is required.

[40]

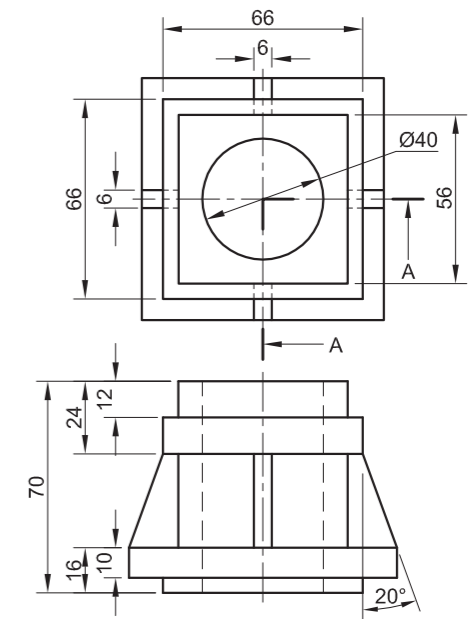

ASSESSMENT CRITERIA	
AUXILIARY VIEW	= 2
ISOMETRIC SURFACES	= 8
NON-ISOMETRIC LINES	= 2
CUT	= 12
ISOMETRIC CIRCLES	= 4
CIRCLE CONSTRUCTION	= 4
HATCHING	= 6
CENTRE LINES	= 2
TOTAL	= 40

EXAMINATION NUMBER	
EXAMINATION NUMBER	4