

FLOOR FINISHES

1. OPEN AREA:	TILE
2. BATHROOM:	TILE
3. BEDROOM:	CARPET
4. OFFICE:	LAMINATE

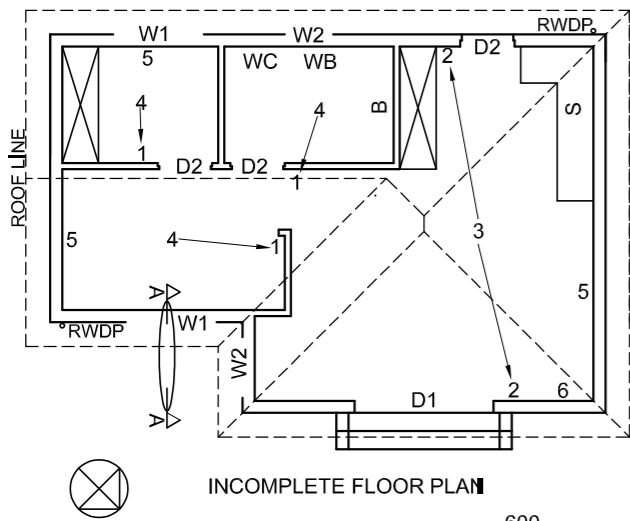

- FEATURES**
- D1 SLIDING DOOR
 - D2 DOOR
 - W1 WINDOW
 - W2 WINDOW
- FIXTURES**
- B BATH
 - S SINK
 - WC TOILET
 - WB WASH BASIN
- ELECTRICAL FITTINGS**
1. ONE-WAY SWITCH - SINGLE-POLE
 2. TWO-WAY SWITCH
 3. FLUORESCENT LIGHT 4 x 40 W
 4. CEILING LIGHT
 5. SWITCHED SOCKET OUTLET
 6. DISTRIBUTION BOARD

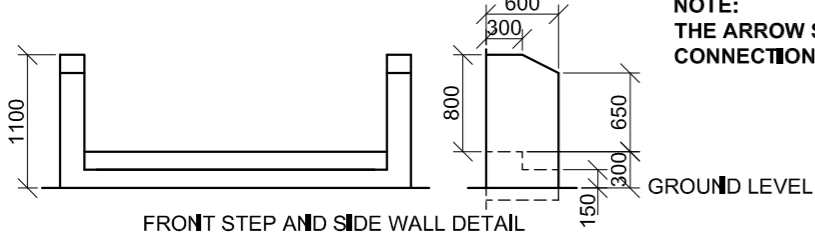

NOTE:
 THE ARROW SHOWS THE LIGHT CONNECTION TO THE SWITCH

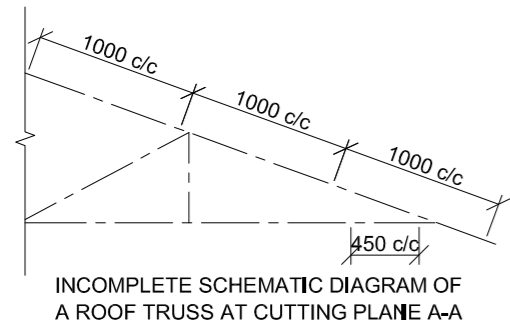

- ROOF NOTES:**
- 20° ROOF PITCH
 - 114 x 40 mm ROOF TRUSSES ON
 - 114 x 40 mm WALL PLATES
 - 400 mm ROOF OVERHANG TO END OF ROOF TRUSS
 - 40 mm CORRUGATED ROOF SHEET ON
 - 75 x 50 mm PURLINS @ 1000 mm c/c
 - 300 x 75 mm BARGE BOARD ON GABLE ENDS AND
 - 200 x 20 mm FASCIA BOARD WITH
 - 150 x 100 mm GUTTERS ON ALL SIDES
 - 10 mm CEILING BOARD ON 40 x 40 mm
 - BRANDING STRIPS @ 450 mm c/c

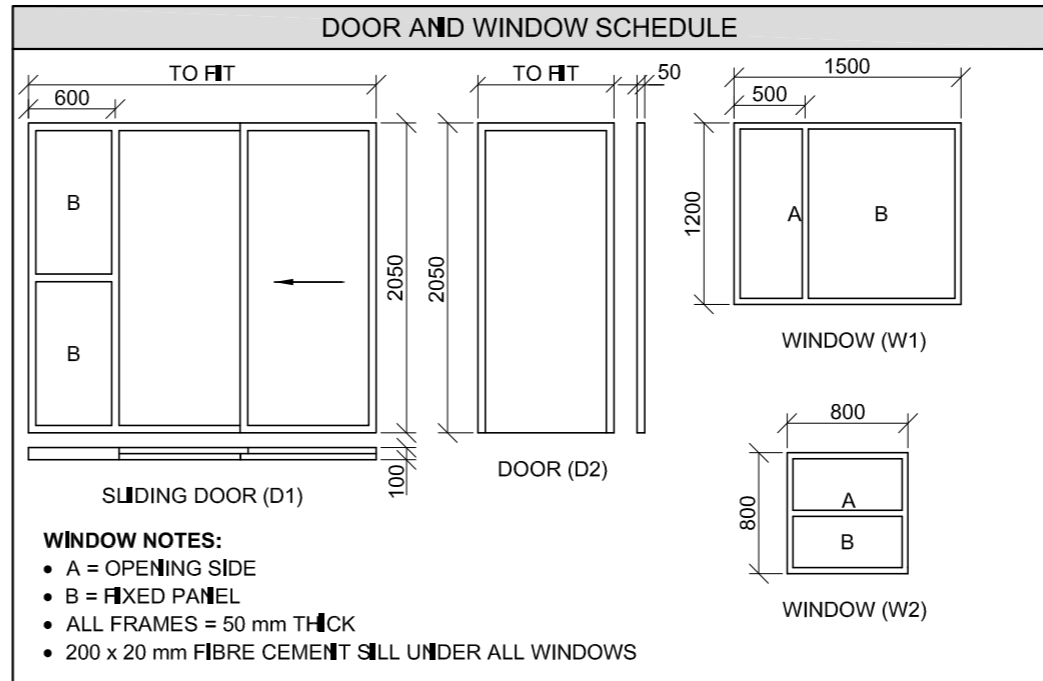
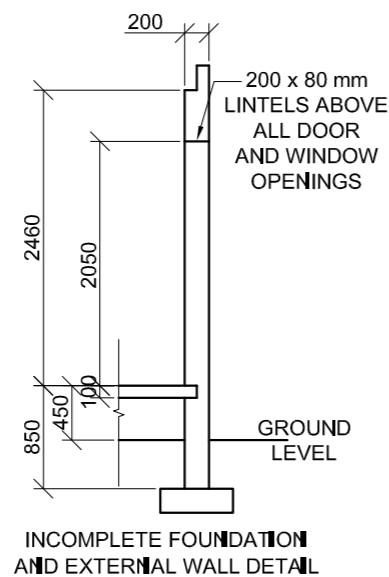

ROOF COMPONENTS		ELECTRICAL SYMBOLS	
	200 x 20 mm FASCIA BOARD		
	150 x 100 mm GUTTER		
	75 x 50 mm PURLINS		
	300 x 75 mm BARGE BOARD		
	ROOF CAP AND RIDGE CAP		

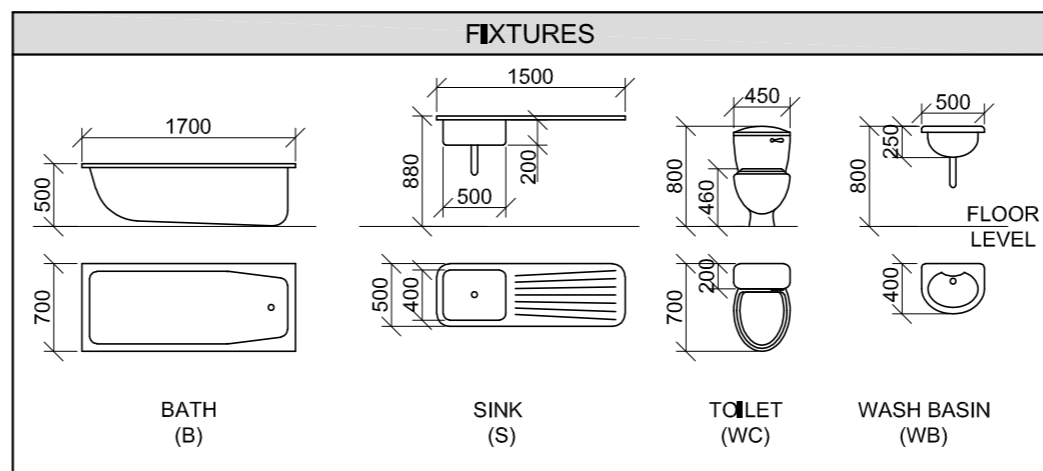

QUESTION 4: CIVIL DRAWING

Given:

- The incomplete north-east elevation of a new house, showing the walls, the window and sliding door openings, the front steps, roof and labels
- The incomplete floor plan showing the walls, front steps, positions of the doors, windows, fixtures and electrical layout
- The front step and side wall detail
- An incomplete schematic diagram of a roof truss at cutting plane A-A and roof notes
- The incomplete foundation and external wall detail
- Room designations and floor finishes
- A door and window schedule
- A table of roof components
- A table of electrical symbols
- A table of fixtures
- The incomplete floor plan and ground level of the new house, drawn to scale 1 : 50, and the incomplete foundation and break lines for the detailed section, drawn to scale 1 : 20, on page 6

Instructions:

Answer this question on page 6.

- 4.1 Using the given incomplete floor plan and ground level, draw, to scale 1 : 50, the following views of the new house:

4.1.1 THE COMPLETE FLOOR PLAN

Add the following features to the drawing:

- ALL doors and windows
- ALL fixtures as indicated by abbreviations
- ALL electrical fittings as indicated by the numbers
- ALL hatching detail

4.1.2 THE COMPLETE NORTH-EAST ELEVATION

Show the following features on the drawing:

- The outside walls, window, sliding door and step detail
- The roof detail including the fascia boards, barge board, gutters and rainwater down-pipe
- The finished floor level

- 4.2 Using the incomplete foundation and break lines on page 6, draw, to scale 1 : 20, a DETAILED SECTION on cutting plane A-A of the area in the ellipse shown on the incomplete floor plan.

Show the following features on the drawing:

- The complete foundation, external wall, slab and window detail
- The roof detail including ALL rainwater items
- The W2 window, roof and rainwater item detail, to the right (north-west) of cutting plane A-A
- ALL hatching detail. ONLY the substructure hatching may be drawn in neat freehand.

Label the following:

- The floor finishes
- Ground level, finished floor level and damp-proof course (use the correct abbreviations and show them on ALL relevant views)

NOTE:

ALL drawings must comply with the guidelines and graphical symbols as contained in the SANS 10143.

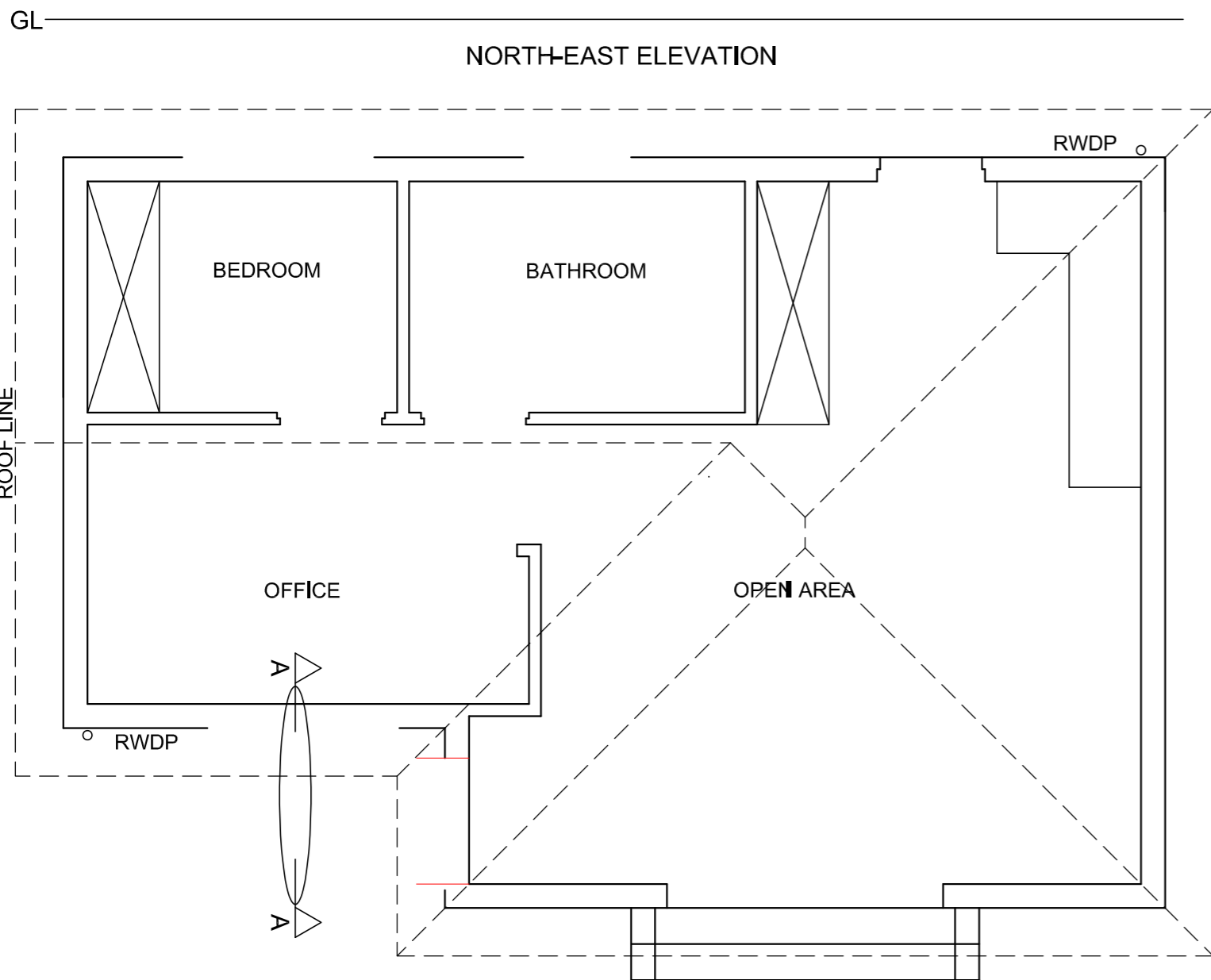

SECTION A-A
SCALE 1 : 20

MARK ALLOCATION FOR SECTION OF ROOF		FOR OFFICIAL USE ONLY	
A		INCORRECT SCALE(S) USED	
B		NON-ALIGNMENT OF VIEWS	
C		VIEW(S) ROTATED	
D		SECTION VIEWED INCORRECTLY	
E		INCORRECT LETTERING	
F			
G			
H			
J			
TOTAL		TOTAL	

ASSESSMENT CRITERIA				
FLOOR PLAN				
		POSSIBLE	OBTAINED	SIGN MODERATED
1	DOORS + WINDOWS	13 1/2		
2	FIXTURES	8		
3	ELECTRICAL	9 1/2		
4	HATCHING	3		
5	LABELS	2		
SUBTOTAL		36		
NORTH-EAST ELEVATION				
1	ROOF + RWDP	8 1/2		
2	WALLS + STEPS	7		
3	DOOR + WINDOW	8		
4	LABELS	1/2		
SUBTOTAL		24		
DETAILED SECTION				
1	ROOF DETAIL	13 1/2		
2	SLAB + WALL	4 1/2		
3	HATCHING	5 1/2		
4	WINDOWS	7		
5	LABELS	1 1/2		
SUBTOTAL		32		
TOTAL		92		
PENALTIES (-)				
GRAND TOTAL				
EXAMINATION NUMBER				
EXAMINATION NUMBER				

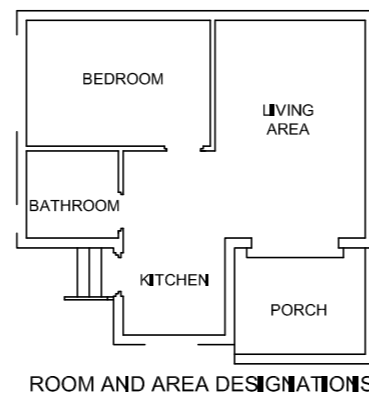
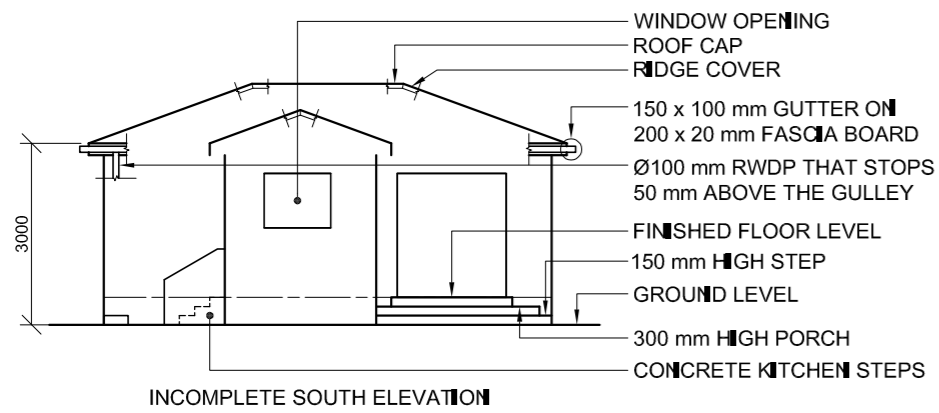

FLOOR FINISHES

BEDROOM:	CARPET
BATHROOM:	TILES
LIVING AREA:	WOOD
KITCHEN:	TILES
PORCH:	WOOD

ROOF COMPONENTS

	150 x 100 mm GUTTER
	200 x 20 mm FASCIA BOARD AND BARGE BOARD
	ROOF CAP

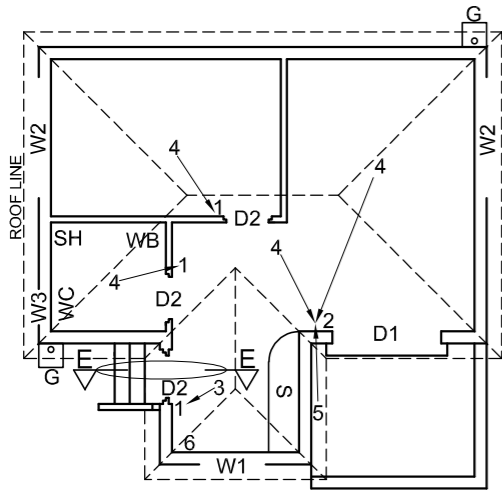

- FEATURES**
- D1 SLIDING DOOR
 - D2 DOOR
 - W1 WINDOW
 - W2 WINDOW
 - W3 WINDOW

- FIXTURES**
- WC TOILET
 - SH SHOWER
 - WB WASH BASIN
 - S SINK

- ELECTRICAL FITTINGS**
- 1 ONE-WAY SWITCH - SINGLE POLE
 - 2 THREE-WAY SWITCH - SINGLE POLE
 - 3 FLUORESCENT LIGHT 2 x 40 W
 - 4 CEILING LIGHT
 - 5 WALL-MOUNTED LIGHT
 - 6 SWITCHED SOCKET OUTLET

NOTE:
THE ARROW SHOWS THE LIGHT CONNECTION TO THE SWITCH.

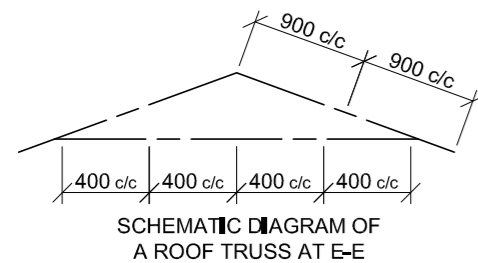

ROOF NOTES:

- 20° ROOF PITCH
- 114 x 40 mm ROOF TRUSSES ON
- 114 x 40 mm WALL PLATES
- 250 mm ROOF OVERHANG TO END OF ROOF TRUSSES
- 20 mm FIBRE CEMENT ROOF SHEETING ON
- 80 x 50 mm PURLINS @ 900 c/c
- 200 x 20 mm FASCIA BOARDS WITH 150 x 100 mm GUTTERS ON ALL SIDES
- 10 mm CEILING BOARDS ON 40 x 40 mm BRANDING STRIPS @ 400 mm c/c

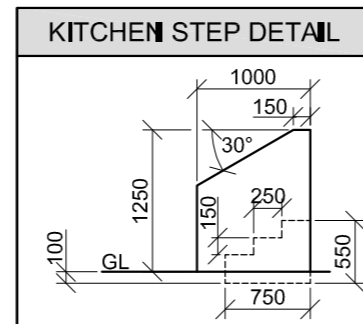
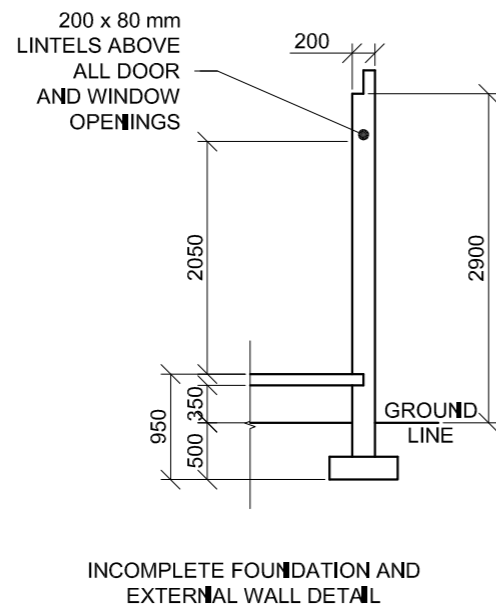

ELECTRICAL SYMBOLS

DOOR AND WINDOW SCHEDULE

SLIDING DOOR (D1)	DOOR FRAME AND DOOR (D2)	WINDOW (W1)
WINDOW (W2)	WINDOW (W3)	

WINDOW NOTES:

- A = OPENING SIDE
- B = FIXED PANEL
- ALL FRAMES = 50 mm
- 150 x 20 mm SILL TILES UNDER ALL WINDOWS

FIXTURES

SINK (S)	SHOWER (SH)	WASH BASIN (WB)	TOILET (WC)

QUESTION 4: CIVIL DRAWING

Given:

- The incomplete south elevation of a new house, showing the walls, the sliding door and window openings, steps, porch, the roof and labels
- The incomplete floor plan showing the roof lines, walls, steps, positions of doors, windows and fixtures, as well as electrical layout
- Schematic diagram of a roof truss at E-E and roof notes
- The incomplete foundation and external wall detail
- Room designations and floor finishes
- A table of roof components
- Kitchen step detail
- A table of electrical symbols
- A door and window schedule
- A table of fixtures
- The incomplete floor plan of the new house, drawn to scale 1 : 50, and the incomplete foundation and a breakline for the detailed section, drawn to scale 1 : 20, on page 6.

Instructions:

Answer this question on page 6.

4.1 Using the given incomplete floor plan, draw, in first-angle orthographic projection and to scale 1 : 50, the following views of the new house:

4.1.1 THE COMPLETE FLOOR PLAN

Add the following features to the drawing:

- ALL doors and windows
- ALL fixtures as indicated by the abbreviations
- ALL electrical fittings as indicated by the numbers
- ALL hatching detail

4.1.2 THE COMPLETE SOUTH ELEVATION

Show the following features on the drawing:

- The outside walls, steps, porch, sliding door and window detail
- The roof detail, including the fascia boards, gutters and rainwater down-pipe
- The finished floor level

4.2 Using the incomplete foundation and break line on page 6, draw, to scale 1 : 20, a DETAILED SECTION on cutting plane E-E of the area in the ellipse shown on the incomplete floor plan.

Show the following features on the drawing:

- The complete foundation, kitchen step, external wall and door detail
- The roof detail, including the fascia board and gutter
- The kitchen step wall, window frame and fascia board below (south of) cutting plane E-E
- ALL hatching detail. ONLY the substructure hatching may be drawn in neat freehand.

Label the following:

- The floor finishes
- Ground level and damp-proof course (use the correct abbreviations and show them on ALL the relevant views)

NOTE:

- ALL drawings must comply with the guidelines and graphical symbols as contained in the SANS 10143.
- NO hidden detail is required.

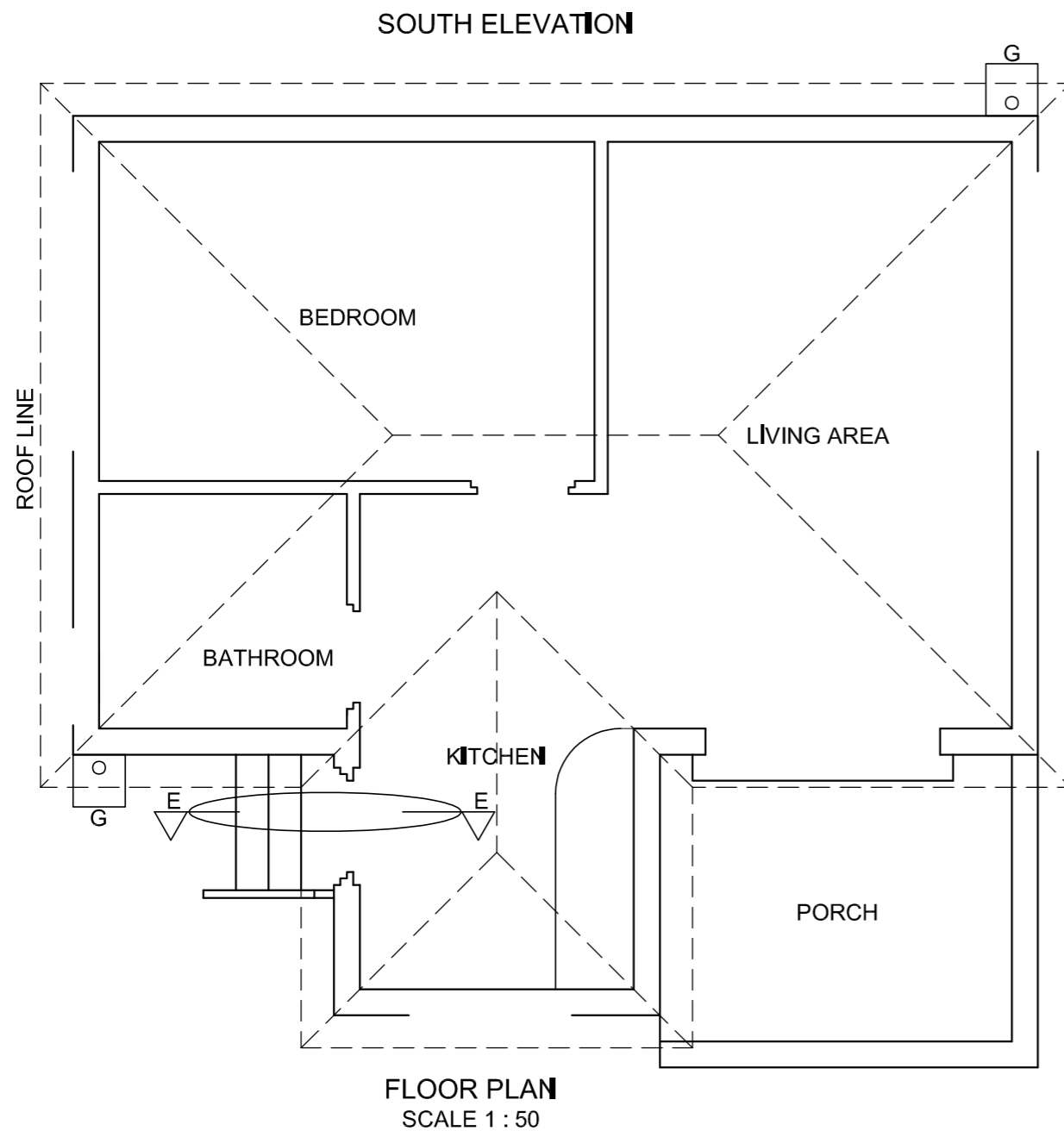

SECTION ON E-E
SCALE 1 : 20

MARK ALLOCATION FOR SECTION OF ROOF		FOR OFFICIAL USE ONLY	
A		INCORRECT SCALE(S) USED	
B		NON-ALIGNMENT OF VIEWS	
C		VIEW(S) ROTATED	
D		SECTION VIEWED INCORRECTLY	
E		INCORRECT LETTERING	
F			
G			
H			
J			
TOTAL		TOTAL	

ASSESSMENT CRITERIA				
FLOOR PLAN				
		POSSIBLE	OBTAINED	SIGN MODERATED
1	DOORS + WINDOWS	13		
2	FIXTURES	8		
3	ELECTRICAL	9		
4	HATCHING	3		
5	LABELS	2 1/2		
SUBTOTAL		35 1/2		
SOUTH ELEVATION				
1	ROOF + RWDP + GULLEY	12		
2	WALLS + FFL	7		
3	DOOR + WINDOW	7		
4	LABELS	1		
SUBTOTAL		27		
DETAILED SECTION				
1	ROOF DETAIL	11 1/2		
2	SLAB + WALL + STEP	9		
3	HATCHING	5 1/2		
4	WINDOW + DOOR	2 1/2		
5	LABELS	1		
SUBTOTAL		29 1/2		
TOTAL		92		
PENALTIES (-)				
GRAND TOTAL				
EXAMINATION NUMBER				
EXAMINATION NUMBER				

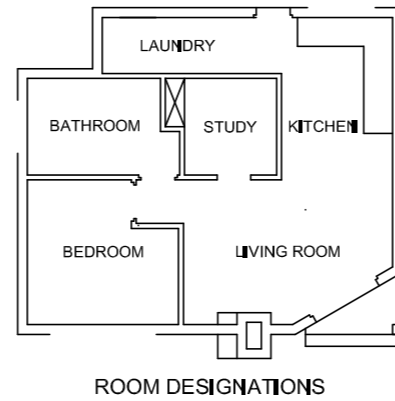
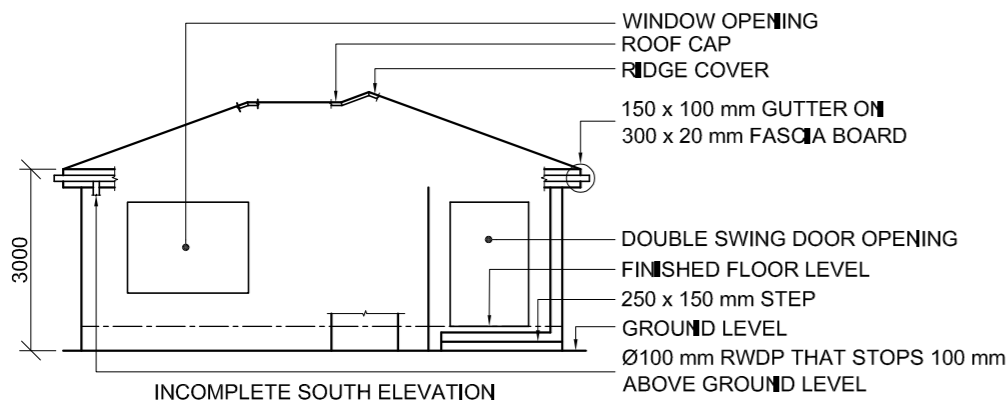

FLOOR FINISHES
 LAUNDRY: TILES
 BATHROOM: TILES
 STUDY: CARPET
 KITCHEN: TILES
 BEDROOM: CARPET
 LIVING ROOM: WOOD

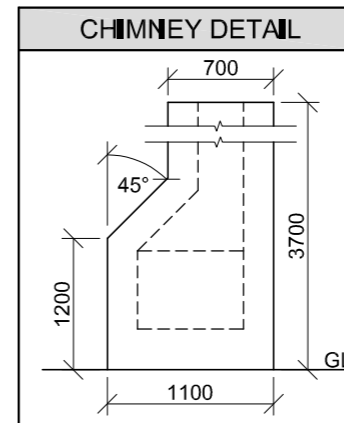

QUESTION 4: CIVIL DRAWING

Given:

- The incomplete south elevation of a new house, showing the walls, window and double swing door openings, step, position of the chimney, roof and labels
- The incomplete floor plan showing the walls, step, positions of the doors, windows, chimney and fixtures, as well as electrical layout
- An incomplete schematic diagram of a roof truss and roof notes
- The incomplete foundation and external wall detail
- Room designations and floor finishes
- A table with chimney detail
- A door and window schedule
- A table of electrical symbols
- A table of fixtures
- The incomplete floor plan and position of the ground level of the new house, drawn to scale 1 : 50, and the incomplete foundation and a break line for the detailed section, drawn to scale 1 : 20, on page 6.

Instructions: Answer this question on page 6.

4.1 Using the given incomplete floor plan and ground level, draw, to scale 1 : 50, the following views of the new house:

4.1.1 THE COMPLETE FLOOR PLAN

Add the following features to the drawing:

- ALL doors and windows
- ALL fixtures as indicated by the abbreviations
- ALL electrical fittings as indicated by the numbers
- ALL the roof lines
- ALL hatching detail

4.1.2 THE COMPLETE SOUTH ELEVATION

Show the following features on the drawing:

- The outside walls, step, chimney, window and double swing door detail
- The roof detail, including the fascia boards, gutters and rainwater down-pipe
- The finished floor level

4.2 Using the given incomplete foundation and break line on page 6, draw, to scale 1 : 20, a DETAILED SECTION on cutting plane A-A of the area in the ellipse shown on the incomplete floor plan.

Show the following features on the drawing:

- The complete foundation and external wall detail
- The roof detail, including the fascia board and gutter
- The chimney and the double swing door and frame to the right (east) of cutting plane A-A
- ALL hatching detail. ONLY the substructure hatching may be drawn in neat freehand.

Label the following:

- The south elevation
- The floor finishes
- Ground level, finished floor level and damp-proof course (use the correct abbreviation and show it on ALL relevant views).

NOTE:

All drawings must comply with the guidelines and graphical symbols as contained in the SANS 10143. [92]

FEATURES

- D1 DOOR
- D2 DOUBLE SWING DOOR
- W1 WINDOW
- W2 WINDOW
- W3 WINDOW

FIXTURES

- WC TOILET
- WB WASH BASIN
- WT WASH TUB
- S SINK
- B BATH

ELECTRICAL FITTINGS

- 1. ONE-WAY SWITCH - SINGLE-POLE
- 2. ONE-WAY SWITCH - DOUBLE-POLE
- 3. FLUORESCENT LIGHT 2 x 40 W
- 4. CEILING LIGHT
- 5. WALL-MOUNTED LIGHT
- 6. SWITCHED SOCKET OUTLET

NOTE:

THE ARROW SHOWS THE LIGHT CONNECTION TO THE SWITCH.

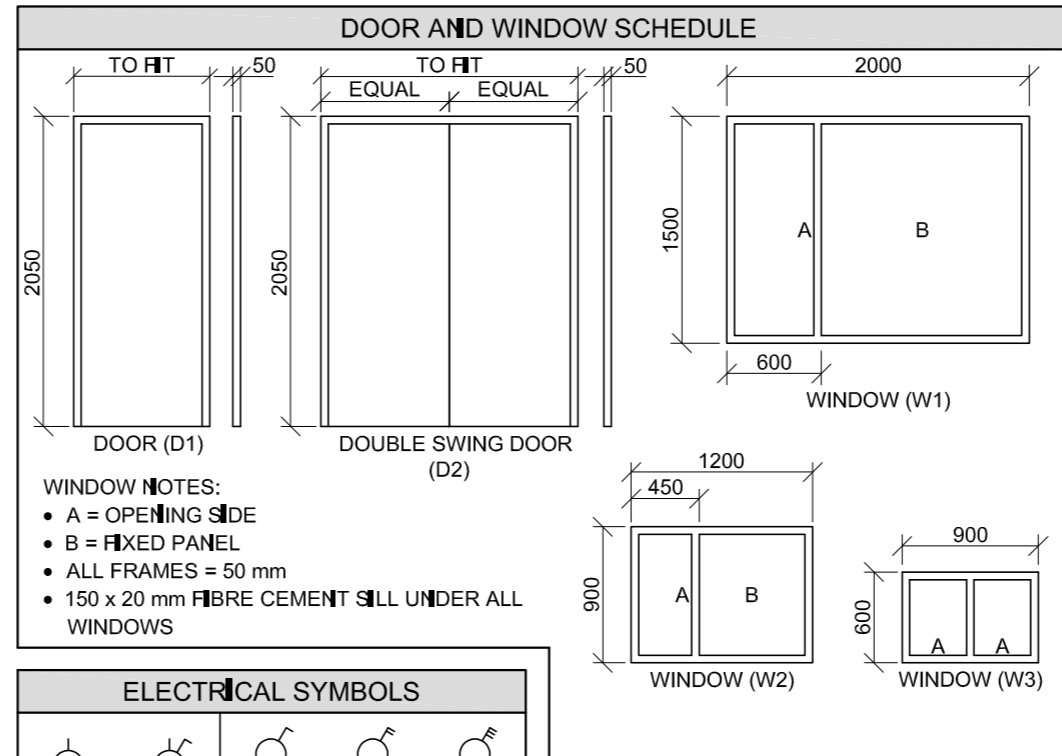

ELECTRICAL SYMBOLS	

ROOF COMPONENTS	
	300 x 20 mm FASCIA BOARD
	150 x 100 mm GUTTER
	ROOF CAP AND RIDGE COVER

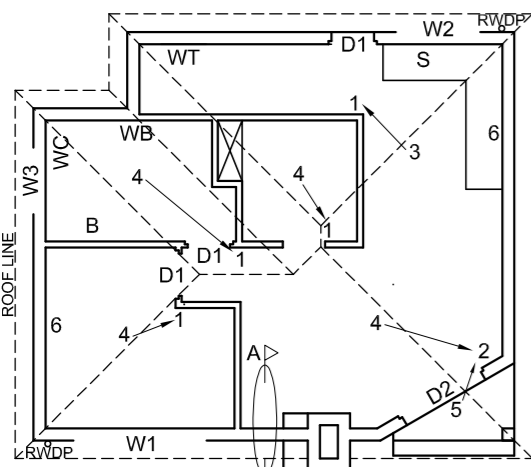
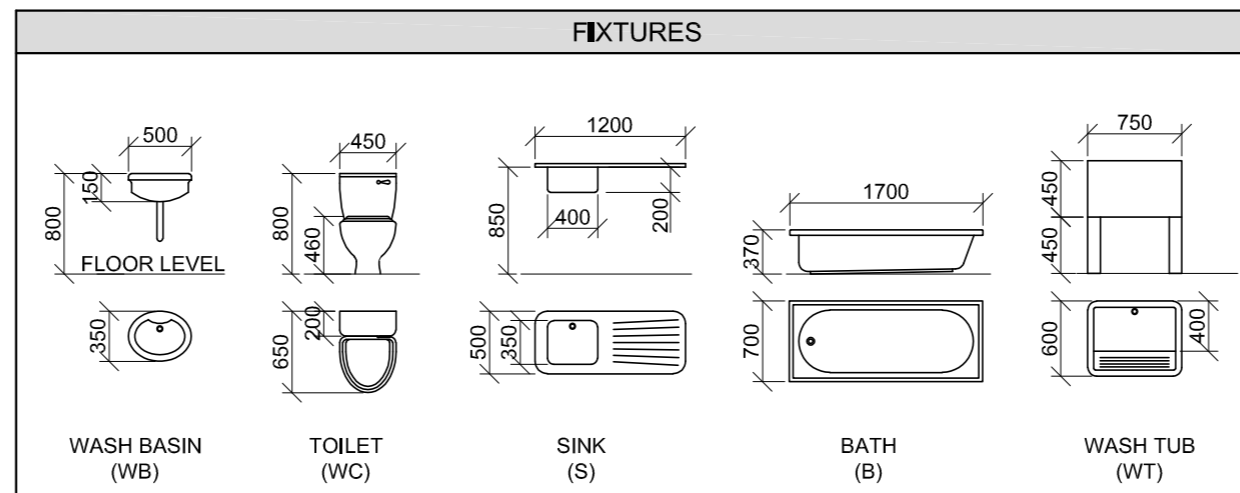

INCOMPLETE FLOOR PLAN

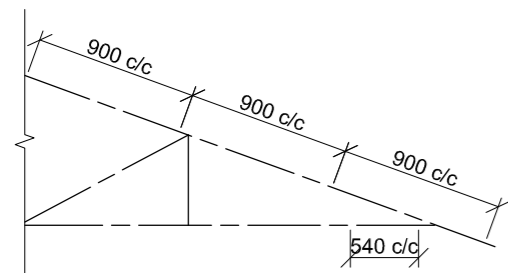

INCOMPLETE SCHEMATIC DIAGRAM OF A ROOF TRUSS

ROOF NOTES:

- 20° ROOF PITCH
- 114 x 40 mm ROOF TRUSSES ON
- 114 x 40 mm WALL PLATES
- 300 mm ROOF OVERHANG TO END OF ROOF TRUSS
- 20 mm CORRUGATED ROOF SHEETING ON
- 75 x 50 mm PURLINS @ 900 mm c/c
- 300 x 20 mm FASCIA BOARDS WITH
- 150 x 100 mm GUTTERS ON ALL SIDES
- 10 mm CEILING BOARD ON
- 40 x 40 mm BRANDING STRIPS @ 540 mm c/c

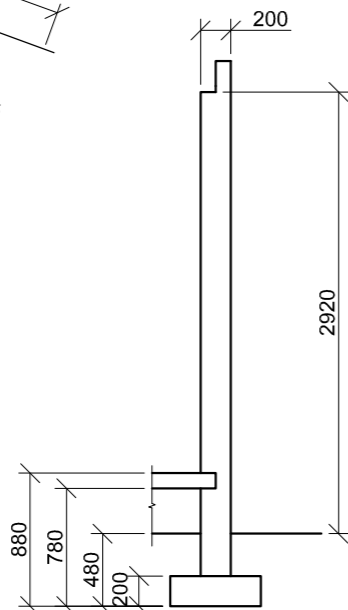

INCOMPLETE FOUNDATION AND EXTERNAL WALL DETAIL



GL

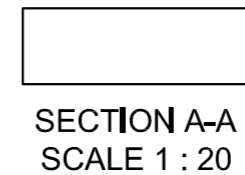
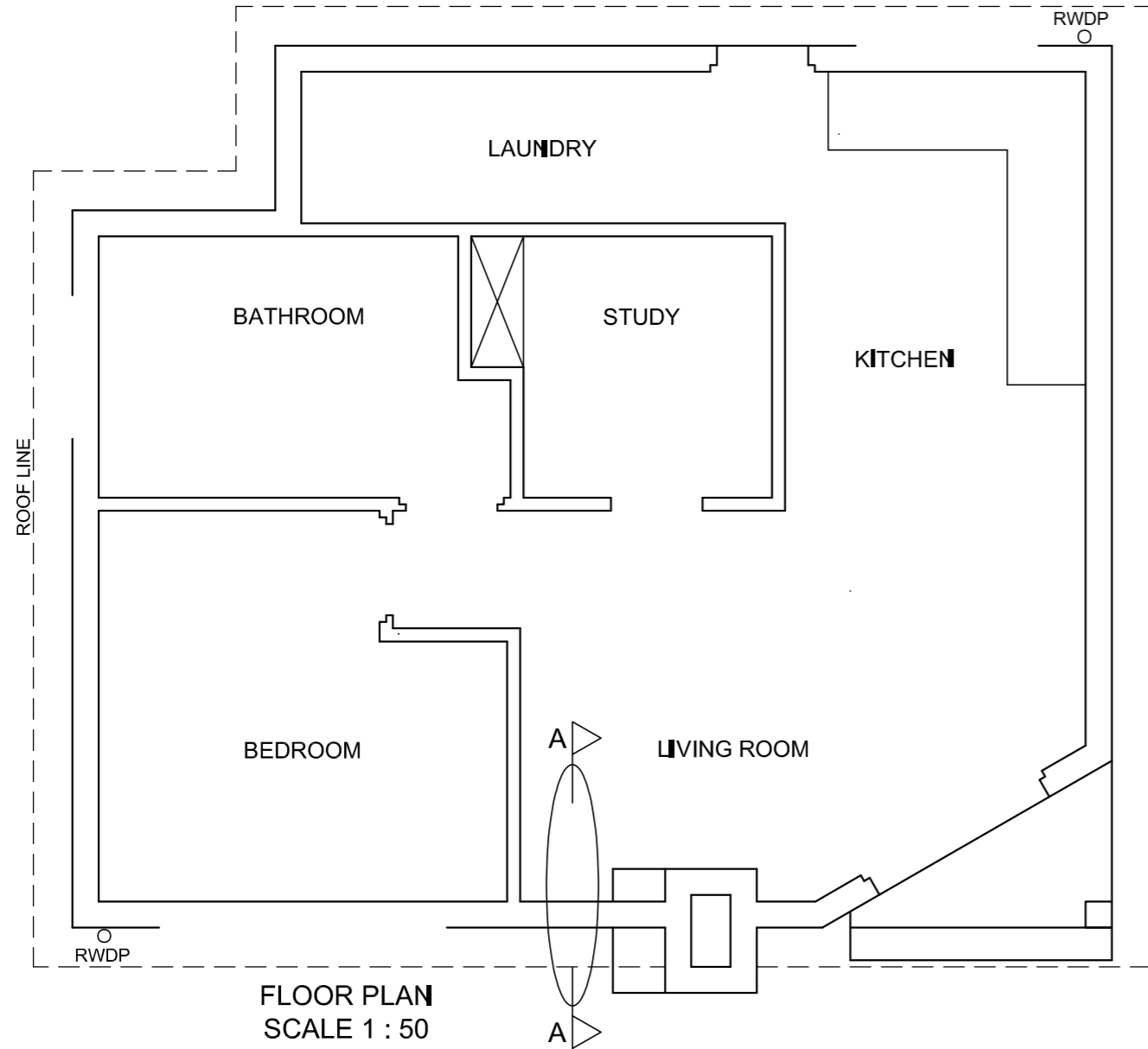

MARK ALLOCATION FOR SECTION OF ROOF		FOR OFFICIAL USE ONLY	
A		INCORRECT SCALE(S) USED	
B		NON-ALIGNMENT OF VIEWS	
C		VIEW(S) ROTATED	
D		SECTION VIEWED INCORRECTLY	
E		INCORRECT LETTERING	
F			
G			
H			
TOTAL		TOTAL	

ASSESSMENT CRITERIA					
FLOOR PLAN					
		POSSIBLE	OBTAINED	SIGN	MODERATED
1	DOORS + WINDOWS	11			
2	FIXTURES + ROOF LINES	15			
3	ELECTRICAL	10			
4	HATCHING	3			
5	LABELS	3			
SUBTOTAL		42			
SOUTH ELEVATION					
1	ROOF + RWDP	8 1/2			
2	WALLS + STEP + CHIMNEY + FFL	7			
3	DOOR + WINDOW	7			
4	LABELS	1			
SUBTOTAL		23 1/2			
DETAILED SECTION					
1	ROOF DETAIL	11 1/2			
2	SLAB + WALL + CHIMNEY	8			
3	HATCHING	3 1/2			
4	DOOR	2 1/2			
5	LABELS	1			
SUBTOTAL		26 1/2			
TOTAL		92			
PENALTIES (-)					
GRAND TOTAL					
EXAMINATION NUMBER					
EXAMINATION NUMBER					

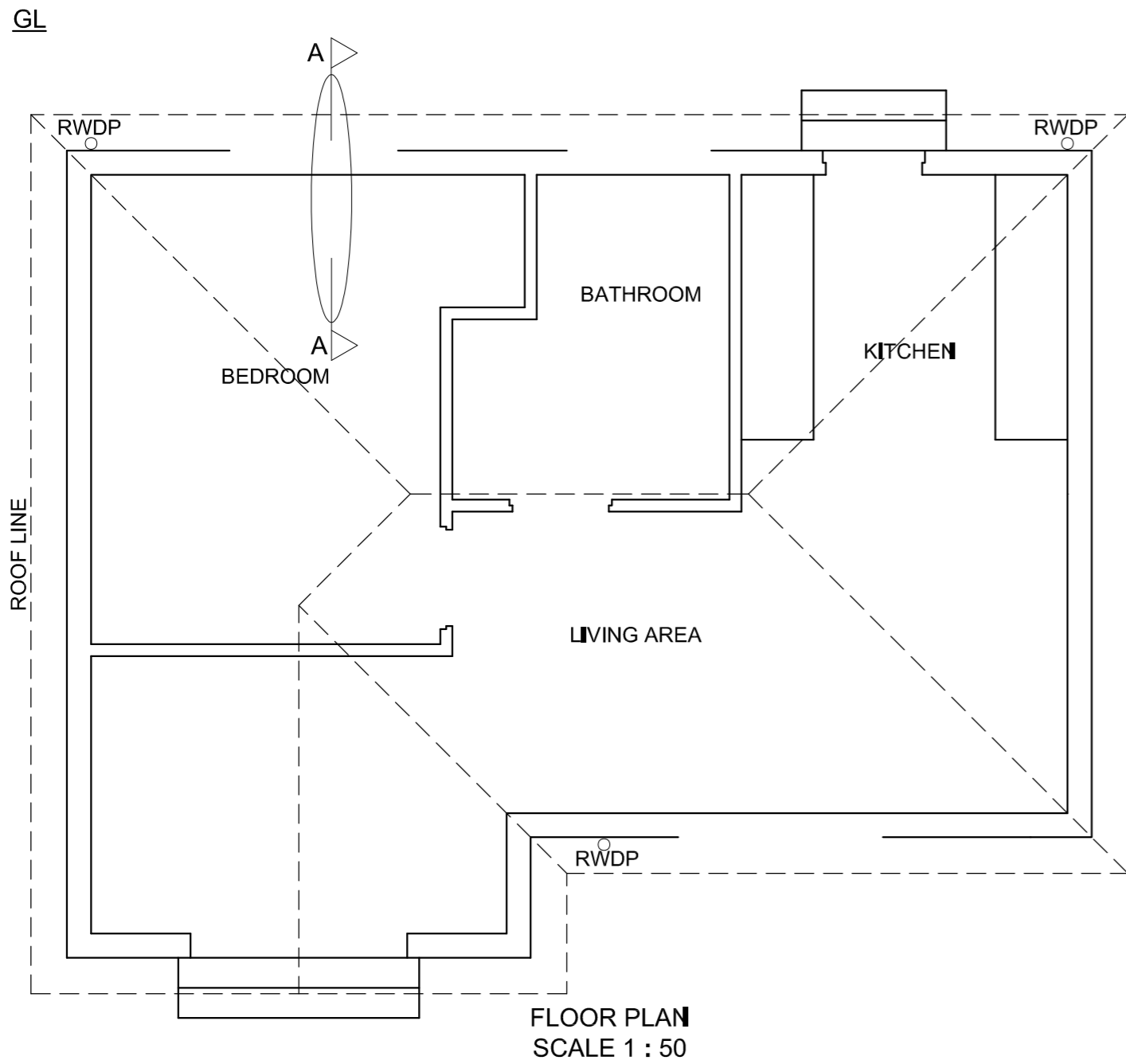

MARK ALLOCATION FOR SECTION OF ROOF		FOR OFFICIAL USE ONLY	
A		INCORRECT SCALE(S) USED	
B		NON-ALIGNMENT OF VIEWS	
C		VIEW(S) ROTATED	
D		SECTION VIEWED INCORRECTLY	
E		INCORRECT LETTERING	
F			
G			
H			
J			
TOTAL		TOTAL	

ASSESSMENT CRITERIA				
FLOOR PLAN				
		POSSIBLE	OBTAINED	SIGN MODERATED
1	DOORS + WINDOWS	11		
2	FIXTURES	9		
3	ELECTRICAL	9 1/2		
4	HATCHING	3		
5	LABELS	2		
SUBTOTAL		34 1/2		
SOUTH-WEST ELEVATION				
1	ROOF + RWDP	9 1/2		
2	WALLS + STEP + FFL	4 1/2		
3	DOOR + WINDOW	8 1/2		
4	LABELS	1		
SUBTOTAL		23 1/2		
DETAILED SECTION				
1	ROOF DETAIL	13		
2	SLAB + WALL + WINDOW + STEP	11 1/2		
3	HATCHING	5 1/2		
4	BIC	2 1/2		
5	LABELS	1 1/2		
SUBTOTAL		34		
TOTAL		92		
PENALTIES (-)				
GRAND TOTAL				
EXAMINATION NUMBER				
EXAMINATION NUMBER				

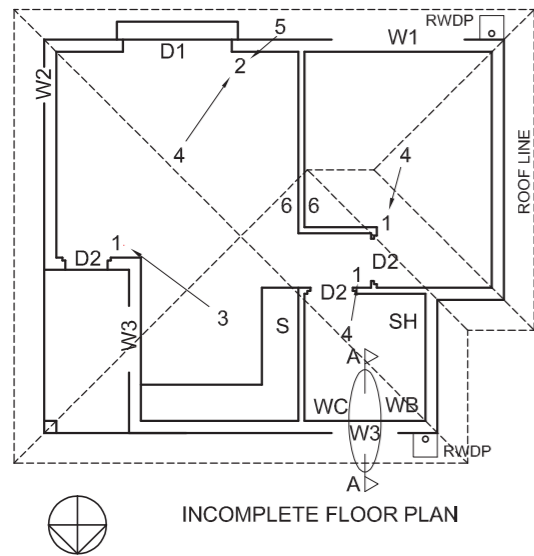
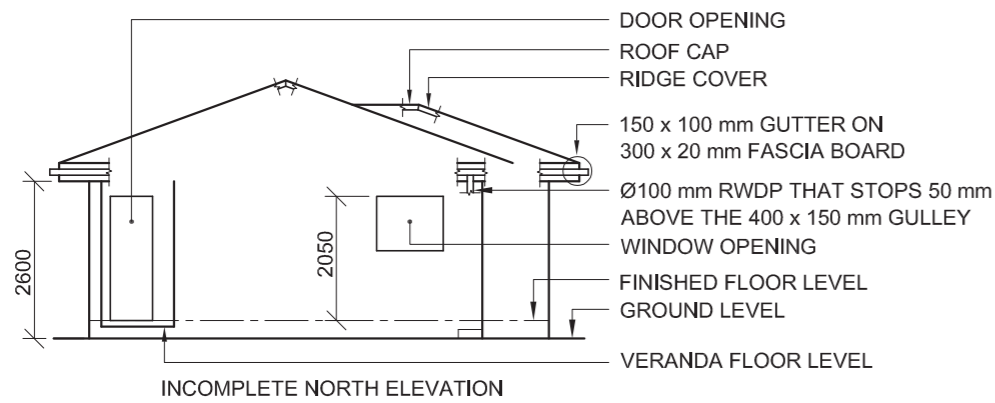

- FEATURES**
D1 SLIDING DOOR
D2 DOOR
W1 WINDOW
W2 WINDOW
W3 WINDOW
- FIXTURES**
WC TOILET
WB WASH BASIN
SH SHOWER
S SINK
- ELECTRICAL FITTINGS**
1. ONE-WAY SWITCH - SINGLE-POLE
2. ONE-WAY SWITCH - DOUBLE-POLE
3. FLUORESCENT LIGHT 3 x 45 W
4. CEILING LIGHT
5. WALL-MOUNTED LIGHT
6. SWITCHED SOCKET OUTLET
- NOTE:**
THE ARROW SHOWS THE LIGHT CONNECTION TO THE SWITCH.

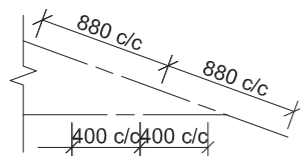

SCHEMATIC DIAGRAM OF A ROOF TRUSS AT A-A

- ROOF NOTES:**
 20° ROOF PITCH
- 114 x 40 mm ROOF TRUSSES ON
 114 x 40 mm WALL PLATES
- 500 mm ROOF OVERHANG TO END OF
 ROOF TRUSS
- 20 mm FIBRE CEMENT ROOF SHEET
 ON 75 x 50 mm PURLINS @ 880 mm c/c
- 300 x 20 mm FASCIA BOARD WITH
 150 x 100 mm GUTTER ON ALL SIDES
- 10 mm CEILING BOARD ON 40 x 40 mm
 BRANDING STRIPS @ 400 mm c/c

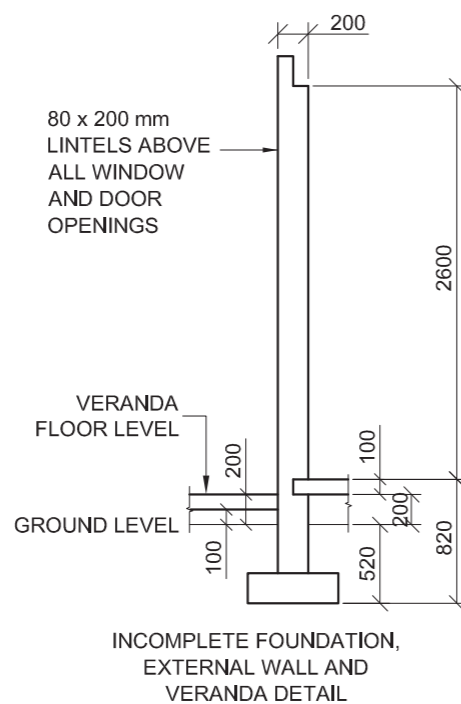

- FLOOR FINISHES**
 BEDROOM: CARPET
 BATHROOM: TILES
 LIVING ROOM: WOOD
 KITCHEN: TILES
 VERANDA: TILES

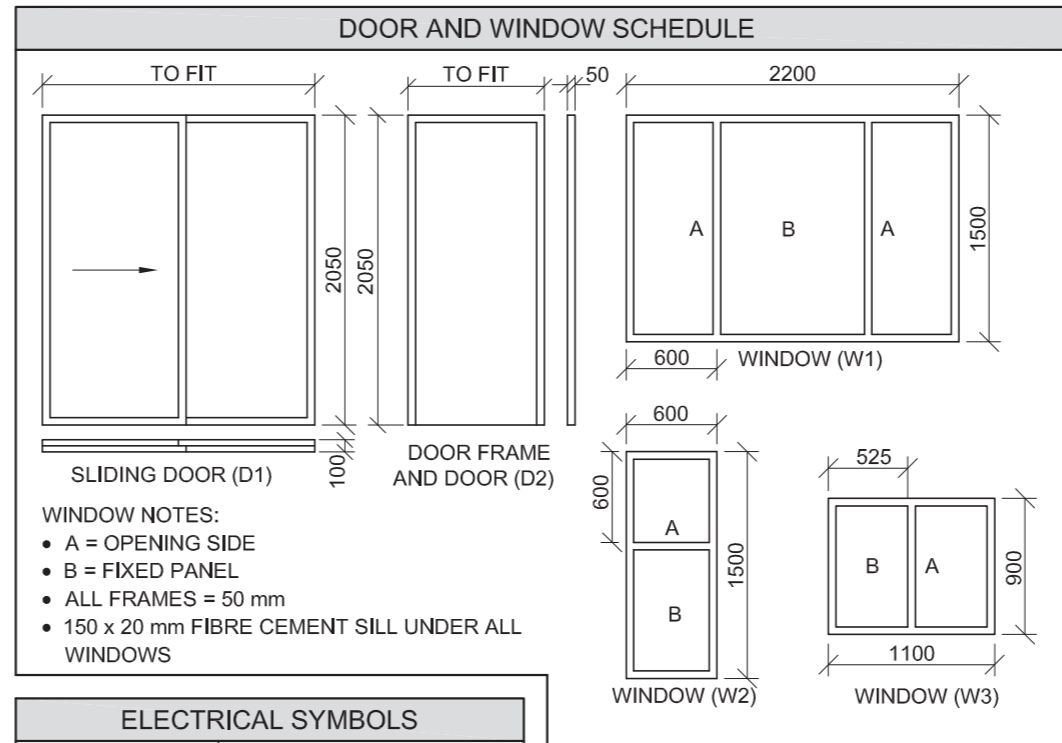
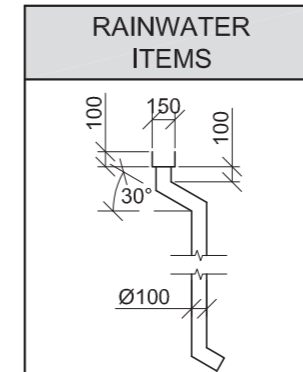

ELECTRICAL SYMBOLS	

ROOF COMPONENTS	
	300 x 20 mm FASCIA BOARD
	150 x 100 mm GUTTER
	ROOF CAP AND RIDGE COVER

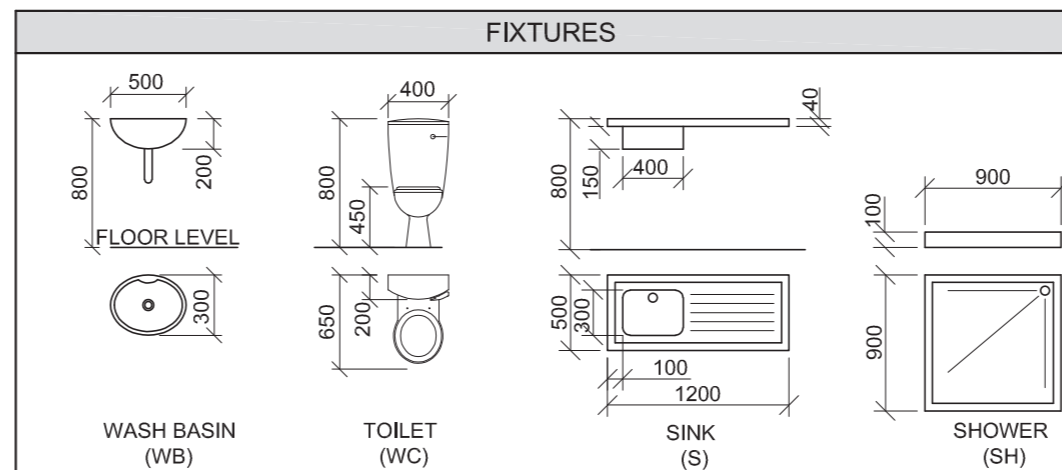

QUESTION 4: CIVIL DRAWING

Given:

- The incomplete north elevation of a **new house**, showing the walls, the window and door openings, the veranda, the roof and labels
- The incomplete floor plan showing the walls, positions of the doors, windows, fixtures and electrical layout
- A schematic diagram of a roof truss at A-A and roof notes
- The incomplete foundation, external wall and veranda detail
- Room and area designations as well as floor finishes
- A table of rainwater items
- A door and window schedule
- A table of electrical symbols
- A table of roof components
- A table of fixtures
- The incomplete floor plan and the ground line of the **new house**, drawn to scale 1 : 50, and the incomplete foundation and a break line for the detailed section, drawn to scale 1 : 20, on page 6.

Instructions:

Answer this question on page 6.

4.1 Using the given incomplete floor plan, draw, to scale 1 : 50, the following views of the **new house**:

4.1.1 THE COMPLETE FLOOR PLAN

Add the following features to the drawing:

- ALL doors and windows
- ALL fixtures as indicated by the abbreviations
- ALL electrical fittings as indicated by the numbers
- The complete roof lines
- ALL hatching detail

4.1.2 THE COMPLETE NORTH ELEVATION

Show the following features on the drawing:

- The outside walls, veranda, window and door detail
- The roof detail, including the fascia boards, gutters, rainwater down-pipe and gulley
- The finished floor level

4.2 Using the given foundation and break line on page 6, draw, to scale 1 : 20, a **DETAILED SECTION** on cutting plane A-A of the area in the ellipse shown on the incomplete floor plan.

Show the following features on the drawing:

- The complete foundation, external wall and window detail
- The roof detail, including the fascia board, gutter, rainwater down-pipe and gulley
- The wash basin to the west of cutting plane A-A
- ALL hatching detail. ONLY the substructure hatching may be drawn in neat freehand.

Label the following:

- The north elevation
- The floor finishes
- Ground level, finished floor level and damp-proof course (use the correct abbreviations and show it on ALL the relevant views)

NOTE:

ALL drawings must comply with the **guidelines** and **graphical symbols** as contained in the **SANS 10143**. [92]





GL

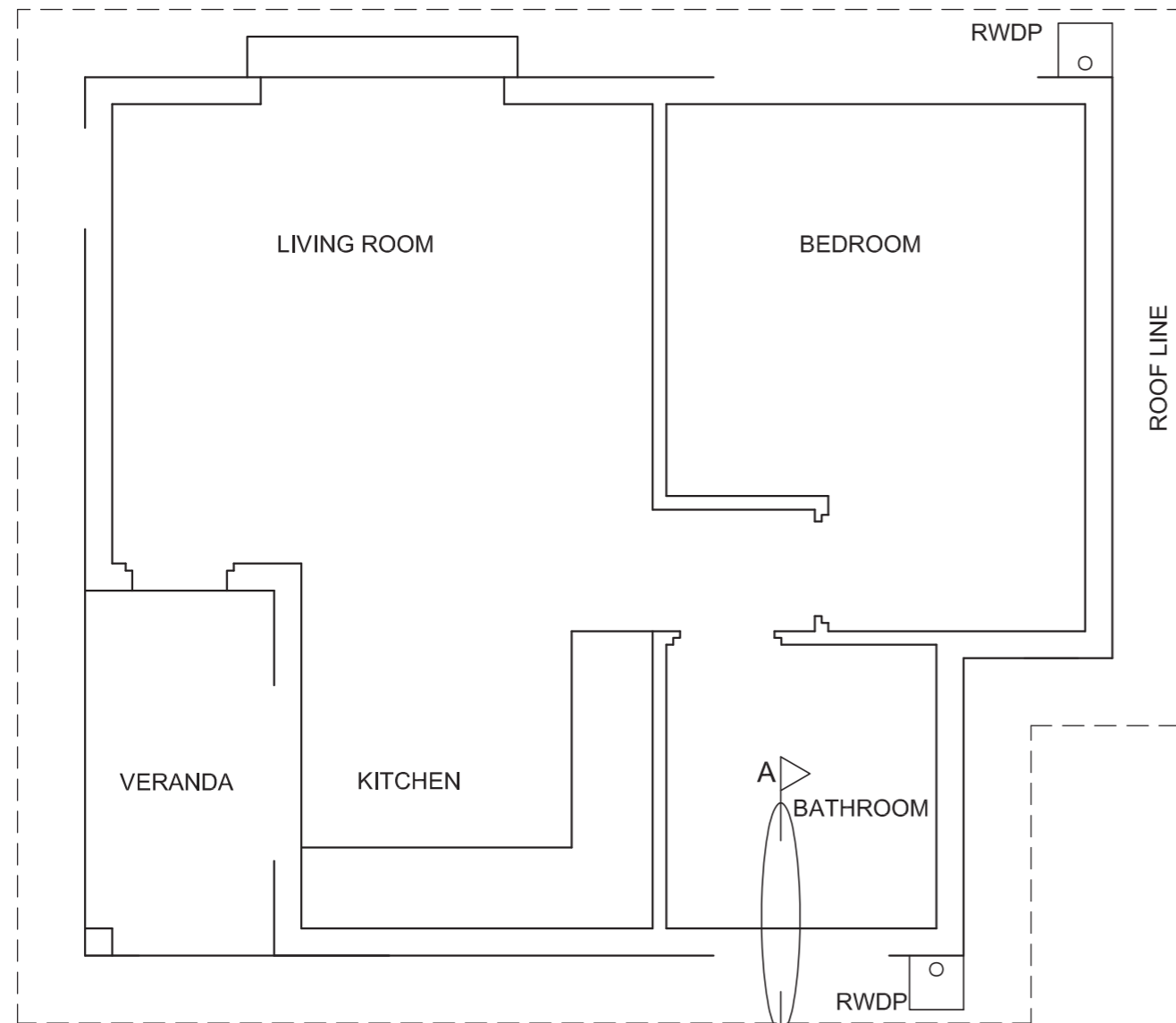

FLOOR PLAN
SCALE 1 : 50

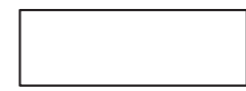

SECTION A-A
SCALE 1 : 20

MARK ALLOCATION FOR SECTION OF ROOF		FOR OFFICIAL USE ONLY	
A		INCORRECT SCALE(S) USED	
B		NON-ALIGNMENT OF VIEWS	
C		VIEW(S) ROTATED	
D		SECTION VIEWED INCORRECTLY	
E		INCORRECT LETTERING	
F			
G			
H			
TOTAL		TOTAL	

ASSESSMENT CRITERIA				
FLOOR PLAN				
		POSSIBLE	OBTAINED	SIGN MODERATED
1	DOORS + WINDOWS	13		
2	FIXTURES + ROOF LINES	11		
3	ELECTRICAL	8 1/2		
4	HATCHING	3		
5	LABELS	2 1/2		
SUBTOTAL		38		
NORTH ELEVATION				
1	ROOF + RWDP + GULLEY	10 1/2		
2	WALLS + STEP + FFL	4		
3	DOOR + WINDOW	6		
4	LABELS	1		
SUBTOTAL		21 1/2		
DETAILED SECTION				
1	ROOF DETAIL	13 1/2		
2	SLAB, WALL, WINDOW + BASIN	12		
3	HATCHING	5 1/2		
4	LABELS	1 1/2		
SUBTOTAL		32 1/2		
TOTAL		92		
PENALTIES (-)				
GRAND TOTAL				
EXAMINATION NUMBER				
EXAMINATION NUMBER				6



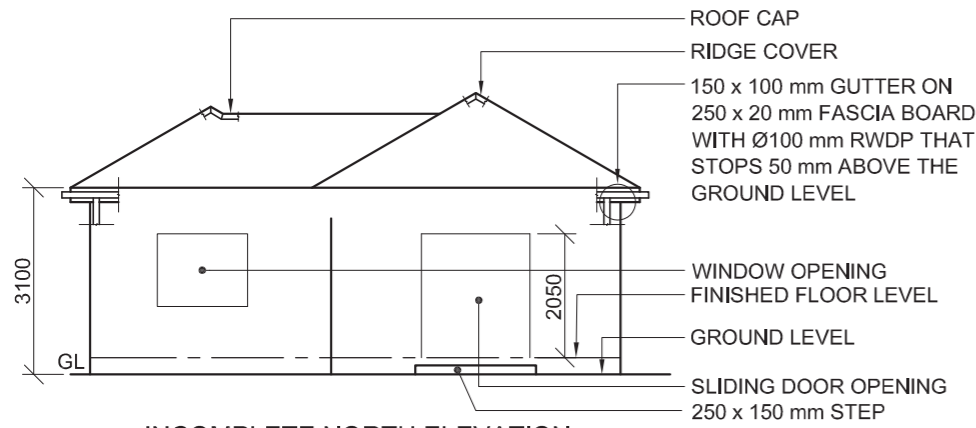

INCOMPLETE NORTH ELEVATION

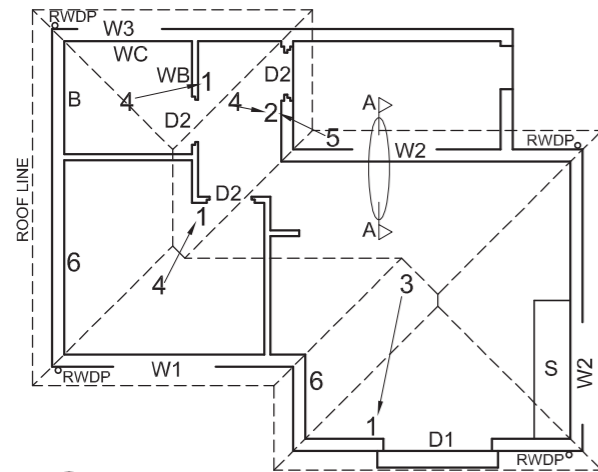

INCOMPLETE FLOOR PLAN

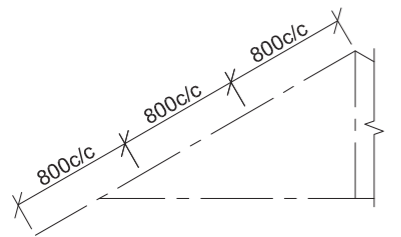

INCOMPLETE SCHEMATIC DIAGRAM OF A ROOF TRUSS AT CUTTING PLANE A-A

ROOF NOTES:
30° ROOF PITCH

115 x 40 mm ROOF TRUSSES ON
115 x 40 mm WALL PLATES

300 mm ROOF OVERHANG TO END OF
ROOF TRUSS

20 mm FIBRE CEMENT ROOF SHEET ON
75 x 50 mm PURLINS @ 800 mm c/c

250 x 20 mm FASCIA BOARDS WITH
150 x 100 mm GUTTERS ON ALL SIDES

10 mm CEILING BOARD ON 40 x 40 mm
BRANDERING STRIPS @ 400 mm c/c

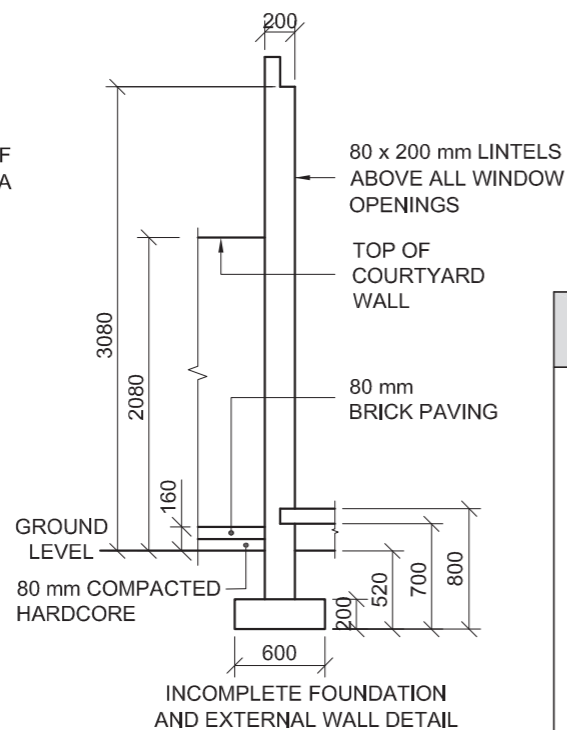

INCOMPLETE FOUNDATION AND EXTERNAL WALL DETAIL

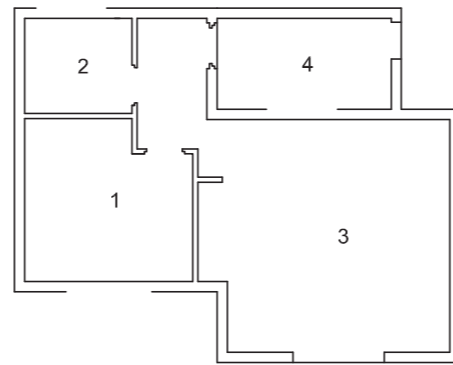

ROOM AND AREA DESIGNATIONS

FLOOR FINISHES

- 1 BEDROOM: VINYL
- 2 BATHROOM: TILE
- 3 LIVING AREA: TILE
- 4 COURTYARD: PAVING

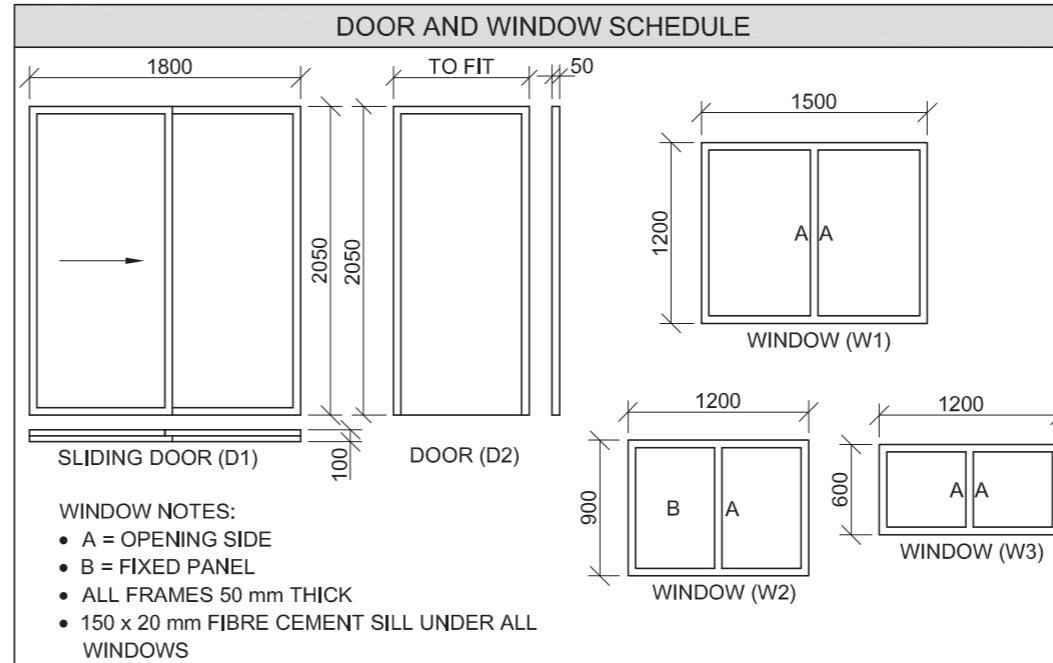

ROOF COMPONENTS		ELECTRICAL SYMBOLS	
	250 x 20 mm FASCIA BOARD		
	150 x 100 mm GUTTER		
	75 x 50 mm PURLINS		
	ROOF CAP AND RIDGE COVER		

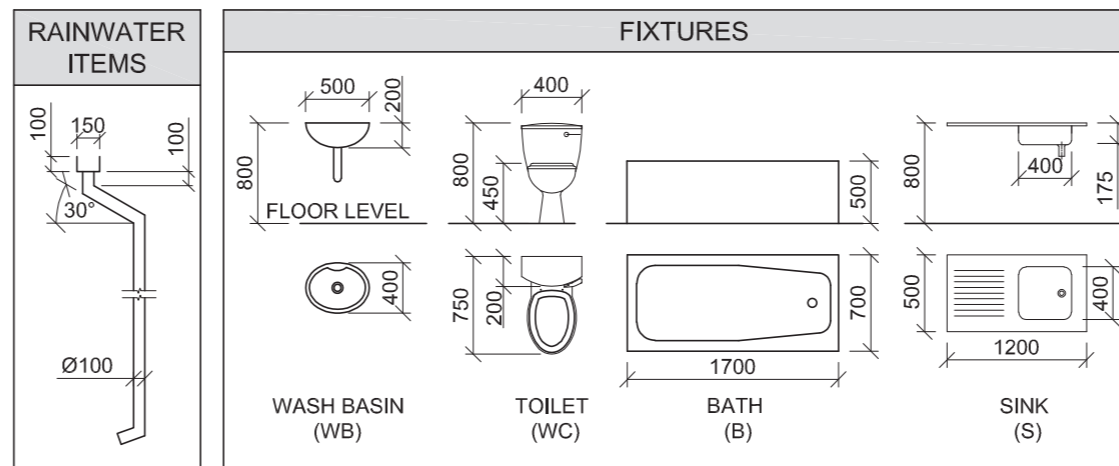

QUESTION 4: CIVIL DRAWING

Given:

- The incomplete north elevation of a **new house**, showing the walls, the window opening, the sliding door opening, the roof and labels
- The incomplete floor plan showing the walls, positions of the doors, windows, fixtures and electrical layout
- An incomplete schematic diagram of a roof truss at cutting plane A-A and roof notes
- The incomplete foundation and external wall detail
- Room and area designations and floor finishes
- A door and window schedule
- A table of roof components
- A table of electrical symbols
- A table of rainwater items
- A table of fixtures
- The incomplete floor plan and ground level of the **new house**, drawn to scale 1 : 50, and the incomplete foundation and break lines of a detailed section, drawn to scale 1 : 20, on page 6

Instructions:

Answer this question on page 6.

4.1 Using the given incomplete floor plan and ground level, draw, to scale 1 : 50, the following views of the **new house**:

4.1.1 THE COMPLETE FLOOR PLAN

Add the following features to the drawing:

- ALL doors and windows
- ALL fixtures as indicated by abbreviations
- ALL electrical fittings as indicated by numbers
- ALL hatching detail

4.1.2 THE COMPLETE NORTH ELEVATION

Show the following features on the drawing:

- The outside walls, step, window and sliding door detail
- The roof detail, including the fascia boards, gutters and rainwater down-pipes
- The finished floor level

4.2 Using the incomplete foundation, draw, to scale 1 : 20 and between the break lines, the **DETAILED SECTION** on cutting plane A-A of the area in the ellipse shown on the incomplete floor plan.

Show the following features on the drawing:

- The paving, complete foundation, external wall and window detail
- The courtyard wall to the east of cutting plane A-A
- The roof detail, including all roof and rainwater items to the east of cutting plane A-A
- ALL hatching detail. ONLY the substructure hatching may be drawn in neat freehand.

Label the following:

- The north elevation
- The room designations and floor finishes
- Ground level, finished floor level and damp-proof course (use the correct abbreviation and show it on ALL relevant views)

NOTE:

ALL drawings must comply with the **guidelines** and **graphical symbols** as contained in the **SANS 10143**. [95]





GL

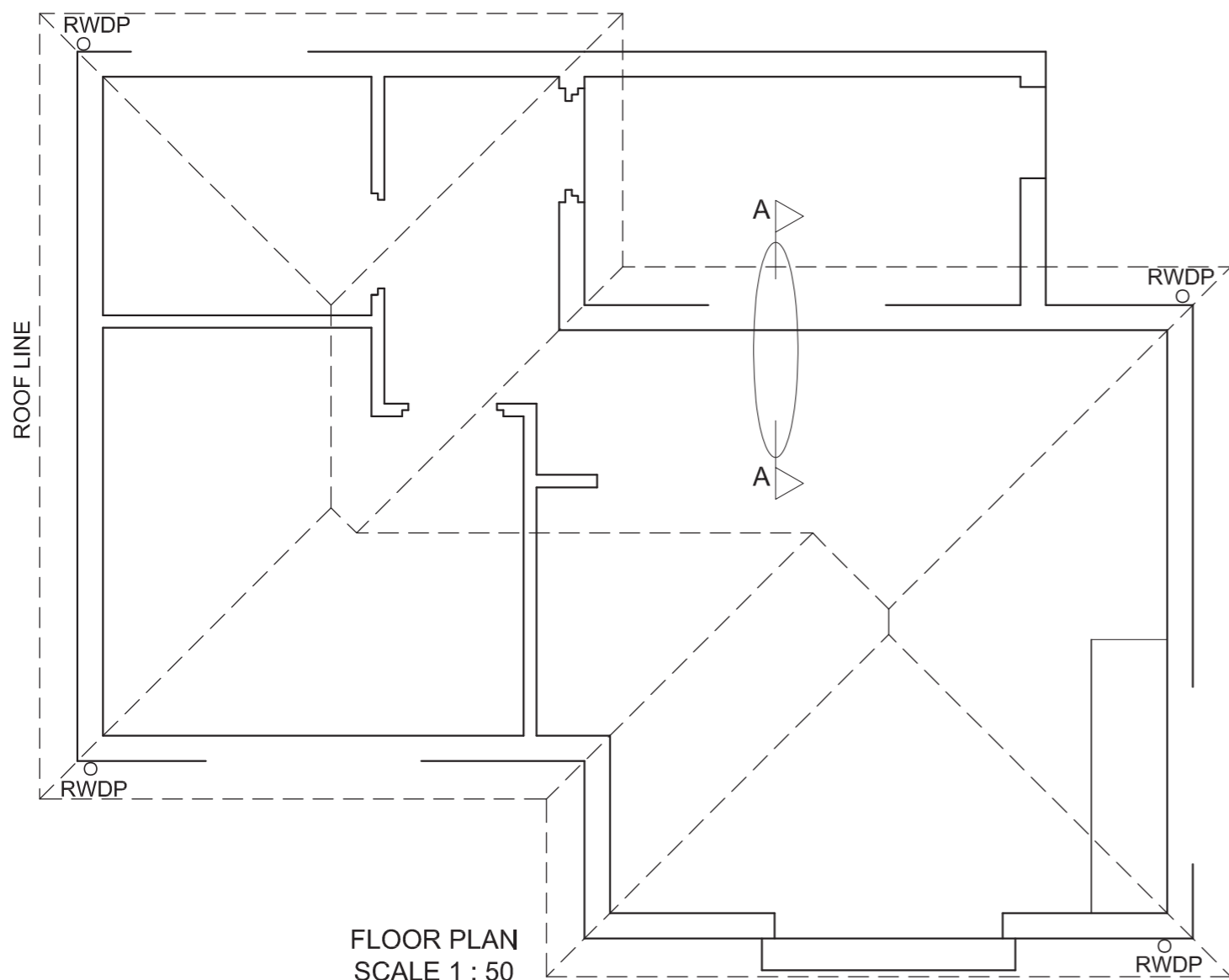

FLOOR PLAN
SCALE 1 : 50



SECTION A-A
SCALE 1 : 20

MARK ALLOCATION FOR SECTION OF ROOF		FOR OFFICIAL USE ONLY	
A		INCORRECT SCALE(S) USED	
B		NON-ALIGNMENT OF VIEWS	
C		VIEW(S) ROTATED	
D		SECTION VIEWED INCORRECTLY	
E		INCORRECT LETTERING	
F			
G			
H			
TOTAL		TOTAL	

ASSESSMENT CRITERIA					
FLOOR PLAN					
		POSSIBLE	OBTAINED	SIGN	MODERATED
1	DOORS + WINDOWS	13			
2	FIXTURES	8			
3	ELECTRICAL	8 1/2			
4	HATCHING	3			
5	LABELS	4			
SUBTOTAL		36 1/2			
NORTH ELEVATION					
1	ROOF + RWDP	11 1/2			
2	WALLS + STEP + FFL	4			
3	DOOR + WINDOW	8			
4	LABELS	1			
SUBTOTAL		24 1/2			
DETAILED SECTION					
1	ROOF DETAIL	14 1/2			
2	SLAB + WALL + WINDOW	11 1/2			
3	HATCHING	6 1/2			
4	LABELS	1 1/2			
SUBTOTAL		34			
TOTAL		95			
PENALTIES (-)					
GRAND TOTAL					
EXAMINATION NUMBER					
EXAMINATION NUMBER					
6					



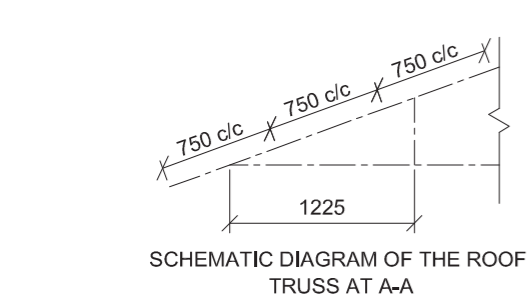
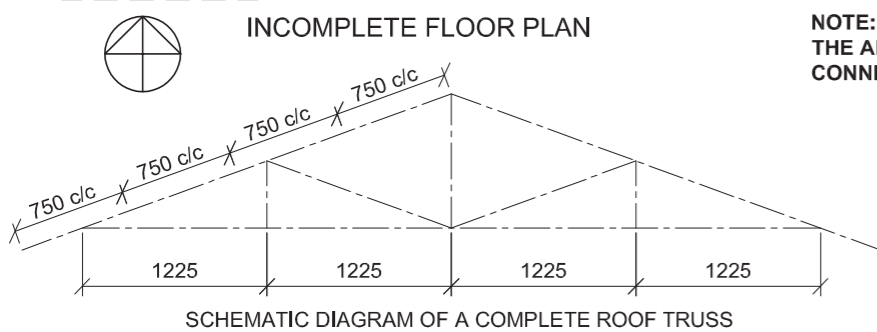
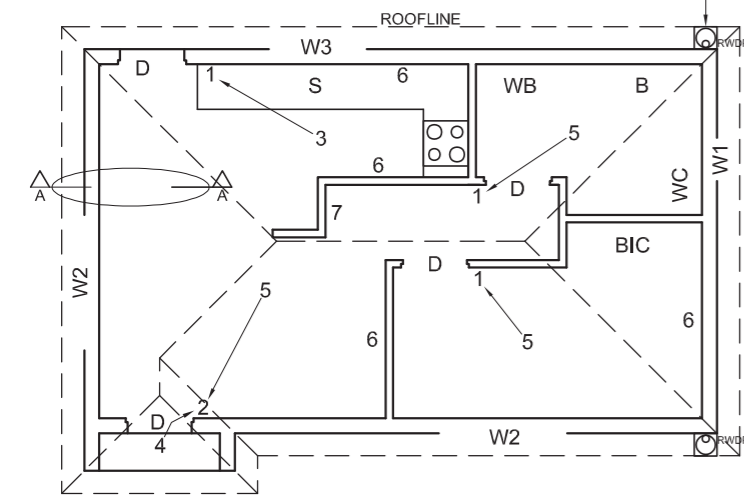
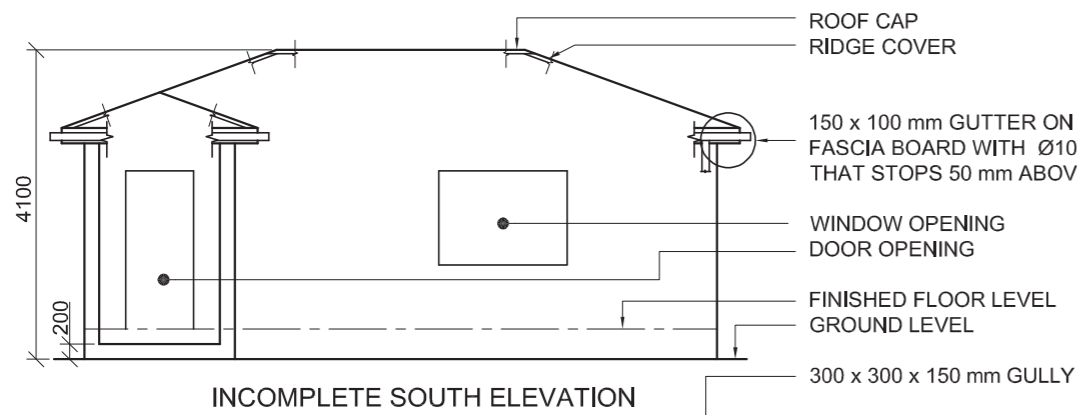

ROOF NOTES:
 20° ROOF PITCH
 114 x 40 mm ROOF TRUSS ON 114 x 40 mm WALL PLATES
 300 mm ROOF OVERHANG TO END OF ROOF TRUSS
 20 mm FIBRE CEMENT ROOF SHEETING ON 75 x 50 mm PURLINS @ 750 mm c/c
 200 x 20 mm FASCIA BOARDS WITH 150 x 100 mm GUTTERS ON ALL SIDES
 10 mm CEILING BOARD ON 40 x 40 mm BRANDING STRIPS @ 600 mm c/c

ROOF CAP
 RIDGE COVER
 150 x 100 mm GUTTER ON 200 x 20 mm FASCIA BOARD WITH Ø100 mm RWDP THAT STOPS 50 mm ABOVE THE GULLY
 WINDOW OPENING
 DOOR OPENING
 FINISHED FLOOR LEVEL
 GROUND LEVEL
 300 x 300 x 150 mm GULLY

FEATURES

D DOOR
 W1 TO W3 WINDOWS

FIXTURES

WC TOILET
 WB WASHBASIN
 B BATH
 S SINK
 BIC BUILT-IN CUPBOARD

ELECTRICAL FITTINGS

1. ONE-WAY SWITCH - SINGLE-POLE
 2. ONE-WAY SWITCH - DOUBLE-POLE
 3. FLUORESCENT LIGHT 2 x 40 W
 4. WALL-MOUNTED LIGHT
 5. CEILING LIGHT
 6. SWITCHED SOCKET OUTLET
 7. DISTRIBUTION BOARD

NOTE:

THE ARROW SHOWS THE LIGHT CONNECTION TO THE SWITCH.

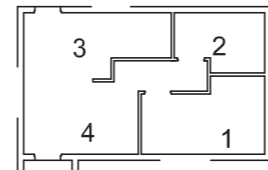

ROOM DESIGNATIONS

FLOOR FINISHES
 1 BEDROOM: CARPET
 2 BATHROOM: TILE
 3 KITCHEN: WOOD
 4 LOUNGE: WOOD

ELECTRICAL SYMBOLS

WINDOW NOTES:

- A = OPENING SIDE
- B = HINGED SIDE
- C = FIXED PANEL
- ALL FRAMES = 50 mm
- 150 x 20 mm FIBRE CEMENT SILL UNDER ALL WINDOWS

ROOF COMPONENTS	
	114 x 40 mm WALL PLATE
	300 ROOF CAP AND RIDGE COVER
	150 x 100 mm GUTTER
	200 x 20 mm FASCIA BOARD

DOOR AND WINDOW SCHEDULE

TO FIT
 50
 2100
 50 mm DOOR FRAME AND DOOR (D)

575
 600
 WINDOW (W1)

1700
 550 550
 1250
 B A C A B
 WINDOW (W2)

1300
 625
 1100
 B A C
 WINDOW (W3)

FIXTURES

TOILET (WC) WASHBASIN (WB) BATH (B) SINK (S)

TO FIT
 600
 BUILT-IN-CUPBOARD (BIC)

NOTE:
 KITCHEN CUPBOARD 850 mm HIGH

QUESTION 4: CIVIL DRAWING

Given:

- The incomplete south elevation of a **new house**, showing the walls, the door and window openings, the roof and labels
- The incomplete floor plan showing the walls, positions of the doors, windows, fixtures and the electrical layout
- Schematic diagrams of roof trusses and roof notes
- The incomplete foundation and external wall detail
- Room designations and floor finishes
- A table of electrical symbols
- A table of roof components
- A table of fixtures
- A door and window schedule
- The incomplete floor plan of the **new house**, drawn to scale 1 : 50, and corner 'B' of the foundation and the break line for the detailed section, drawn to scale 1 : 20, on page 6

Instructions:

Answer this question on page 6.

4.1 Using the given incomplete floor plan, draw, in first-angle orthographic projection and to scale 1 : 50, the following views of the **new house**:

4.1.1 THE COMPLETE FLOOR PLAN

Add the following features to the drawing:

- ALL doors and windows
- The fixtures as indicated by the abbreviations
- ALL electrical fittings as indicated by the numbers
- ALL hatching detail

4.1.2 THE COMPLETE SOUTH ELEVATION

Show the following features on the drawing:

- The outside walls, step, door and window detail
- The roof detail, including the fascia boards, gutters and rainwater down-pipe
- The finished floor level

4.2 Using corner 'B' of the foundation and the break line on page 6, draw, to scale 1 : 20, a **DETAILED SECTION** on cutting plane A-A of the area in the ellipse shown on the incomplete floor plan.

Show the following features on the drawing:

- The foundation and external wall detail
- The roof detail, including the fascia board and gutter
- The door frame and kitchen cupboard north of (above) the ellipse
- ALL hatching detail. ONLY the substructure hatching may be drawn in neat freehand.

Label the following:

- The south elevation
- The room designations and floor finishes
- Ground level, finished floor level, damp-proof course and built-in cupboard (use the correct abbreviations and show it on ALL the relevant views)

NOTE:

ALL drawings must comply with the **guidelines** and **graphical symbols** as contained in the **SANS 10143**. [94]



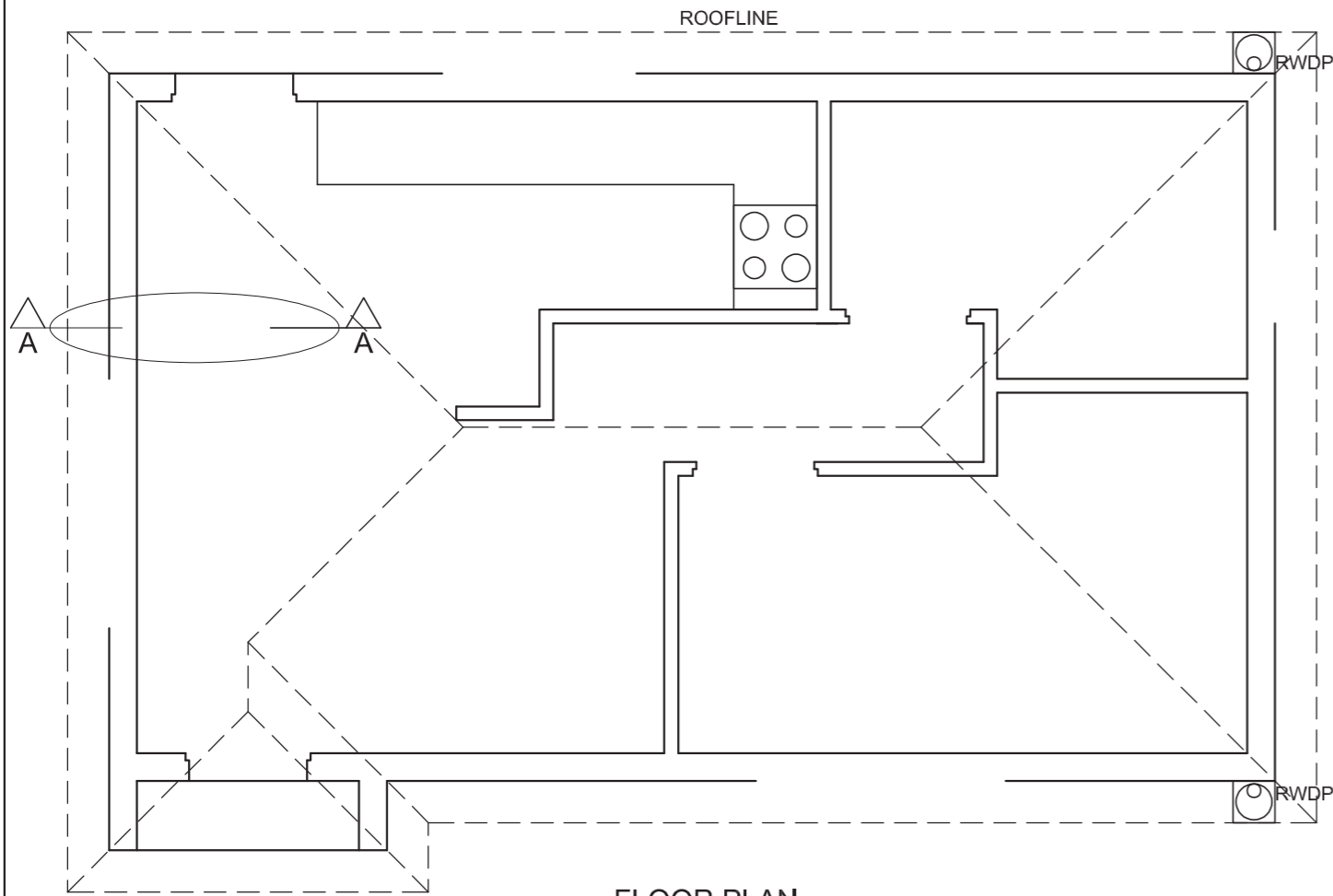

FLOOR PLAN
SCALE 1 : 50

L
B

DETAILED SECTION A-A
SCALE 1 : 20

MARK ALLOCATION FOR ROOF SECTION (4.2)	
A	
B	
C	
D	
E	
F	
G	
H	
I	
TOTAL	

FOR OFFICIAL USE ONLY	
INCORRECT SCALE	
NON-ALIGNMENT OF VIEWS	
VIEW(S) ROTATED	
SECTION VIEWED INCORRECTLY	
INCORRECT LETTERING	
TOTAL	

ASSESSMENT CRITERIA					
FLOOR PLAN					
		POSSIBLE	OBTAINED	SIGN	MODERATED
1	DOORS + WINDOWS	12			
2	ELECTRICAL	10			
3	FIXTURES	9½			
4	HATCHING	3			
5	LABELS	4½			
SUBTOTAL		39			
SOUTH ELEVATION					
1	ROOF + RWDP	10½			
2	WALLS + FFL	5½			
3	DOOR + WINDOW	7½			
4	LABELS	1½			
SUBTOTAL		25			
DETAILED SECTION					
1	ROOF DETAIL	13			
2	WALL	8			
3	DOOR + CUPBOARD	4			
4	HATCHING	4			
5	LABELS	1			
SUBTOTAL		30			
TOTAL		94			
PENALTIES (-)					
GRAND TOTAL					
EXAMINATION NUMBER					
EXAMINATION NUMBER					



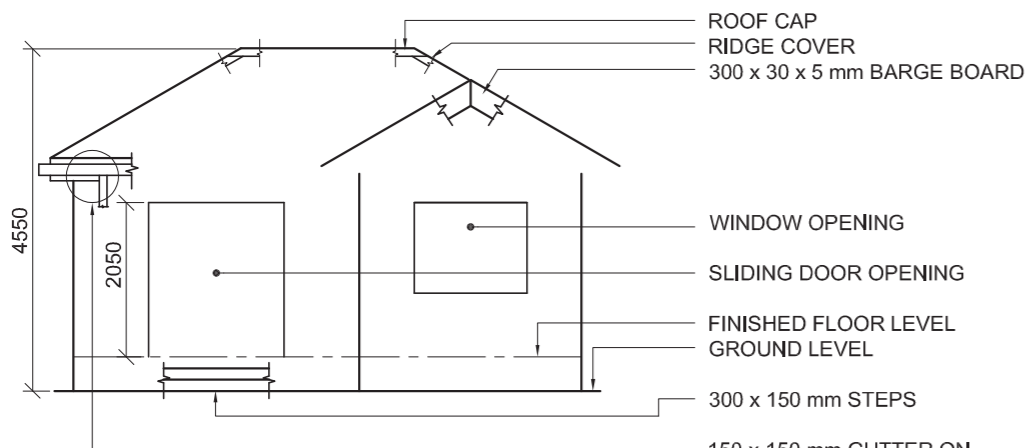

INCOMPLETE NORTH ELEVATION

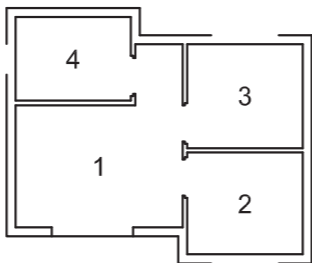

ROOM DESIGNATIONS

FLOOR FINISHES

- 1. LOUNGE: CARPET
- 2. KITCHEN: TILES
- 3. BEDROOM: CARPET
- 4. BATHROOM: TILES

FEATURES

- D1 + D2 DOORS
- W1 + W2 WINDOWS

FIXTURES

- WC TOILET
- WB WASH BASIN
- B BATH
- S SINK

ELECTRICAL FITTINGS

- 1. ONE-WAY SWITCH - SINGLE-POLE
- 2. ONE-WAY SWITCH - DOUBLE-POLE
- 3. FLUORESCENT LIGHT 3 x 40 W
- 4. WALL-MOUNTED LIGHT
- 5. CEILING LIGHT
- 6. SWITCHED SOCKET OUTLET
- 7. SOCKET OUTLET
- 8. DISTRIBUTION BOARD

NOTE:
THE ARROW SHOWS THE LIGHT CONNECTION TO THE SWITCH.

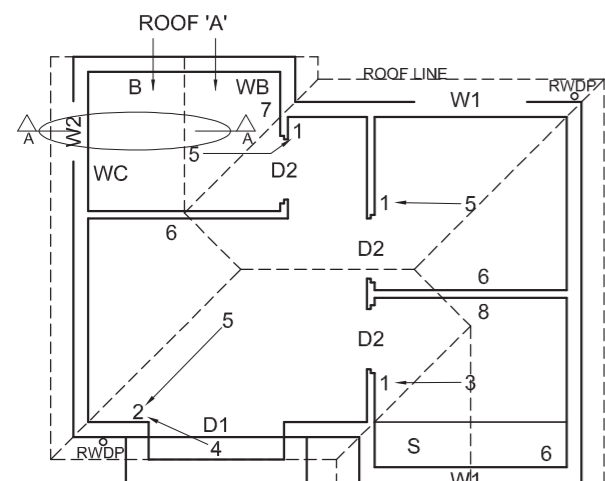

INCOMPLETE FLOOR PLAN

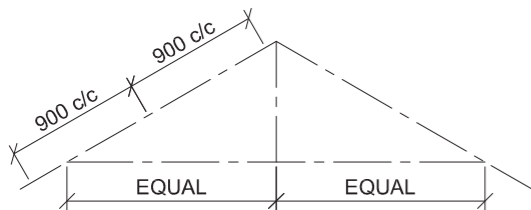

SCHEMATIC DIAGRAM OF A ROOF TRUSS FOR ROOF 'A'

ROOF NOTES:

- 30° ROOF PITCH
- 115 x 40 mm ROOF TRUSSES ON 115 x 40 mm WALL PLATES
- 300 mm ROOF OVERHANG TO END OF ROOF TRUSS
- 20 mm FIBRE CEMENT ROOF SHEETING ON 75 x 50 mm PURLINS @ 900 mm c/c
- 300 x 20 mm FASCIA BOARD WITH 150 x 150 mm GUTTERS ON ALL SIDES
- 300 x 30 x 5 mm BARGE BOARDS ON GABLE ENDS, 40 mm PAST THE GUTTERS
- 8 mm CEILING BOARD ON 40 x 40 mm BRANDING STRIPS @ 600 mm c/c

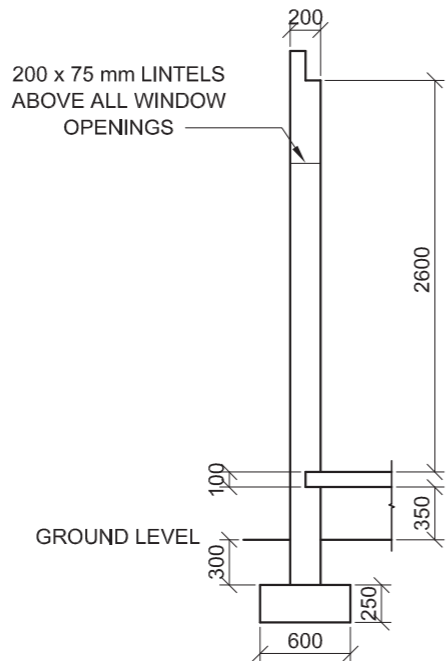

INCOMPLETE FOUNDATION AND EXTERNAL WALL DETAIL

WINDOW AND DOOR SCHEDULE

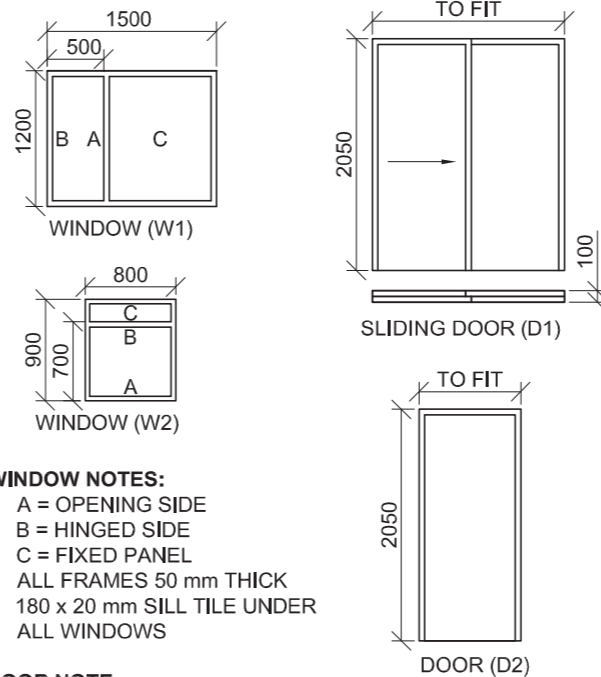

WINDOW NOTES:

- A = OPENING SIDE
- B = HINGED SIDE
- C = FIXED PANEL
- ALL FRAMES 50 mm THICK
- 180 x 20 mm SILL TILE UNDER ALL WINDOWS

DOOR NOTE:

- ALL FRAMES 50 mm THICK

FIXTURES

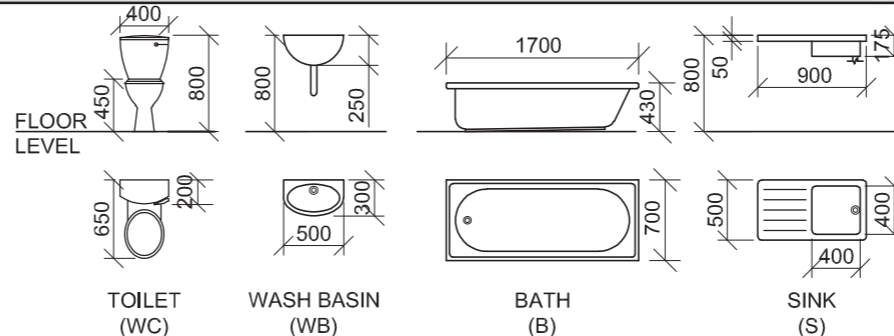

ELECTRICAL SYMBOLS

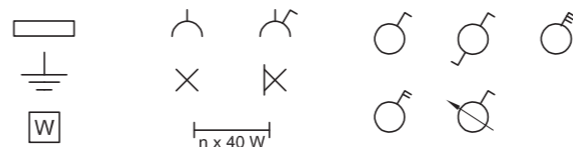

ROOF COMPONENTS

	ROOF CAP AND RIDGE COVER
	150 x 150 mm GUTTER
	300 x 20 mm FASCIA BOARD
	300 x 30 x 5 mm BARGE BOARD

QUESTION 4: CIVIL DRAWING

Given:

- The incomplete north elevation of a **new self-contained flatlet**, showing the walls, the sliding door and window openings, the roof and labels
- The incomplete floor plan showing the walls, steps, position of the doors, windows, fixtures and the electrical layout
- A schematic diagram of a roof truss for roof 'A' and roof notes
- Room designations and floor finishes
- The incomplete foundation and external wall detail
- A window and door schedule
- A table of fixtures
- A table of electrical symbols
- A table of roof components
- The incomplete floor plan of the **new self-contained flatlet**, drawn to scale 1 : 50, and the incomplete foundation and break line for the detailed section, drawn to scale 1 : 20, on page 6

Instructions:

Answer this question on page 6.

4.1 Using the given incomplete floor plan, draw, in first-angle orthographic projection and to scale 1 : 50, the following views of the **new self-contained flatlet**:

4.1.1 THE COMPLETE FLOOR PLAN

Add the following features to the drawing:

- ALL doors and windows
- The fixtures as indicated by the abbreviations
- ALL electrical fittings as indicated by the numbers
- ALL hatching detail

4.1.2 THE COMPLETE NORTH ELEVATION

Show the following features on the drawing:

- The outside walls, steps, window and sliding door detail
- The roof detail, including the barge boards, fascia boards, gutter and rainwater down-pipe
- The finished floor level

4.2 Using the incomplete foundation on page 6, draw, to scale 1 : 20, a **DETAILED SECTION** on cutting plane A-A of the area in the ellipse shown on the incomplete floor plan.

Show the following features on the drawing:

- The complete foundation and external wall detail
- The window detail
- The roof detail, including the fascia board, gutter and barge board
- The bath
- ALL hatching detail. ONLY the substructure hatching may be drawn in neat freehand.

Label the following:

- The north elevation
- The room designations and floor finishes
- Ground level, finished floor level and damp-proof course (use the correct abbreviations and show it on ALL the relevant views)

NOTE:

ALL drawings must comply with the **guidelines** and **graphical symbols** as contained in the **SANS 10143**.



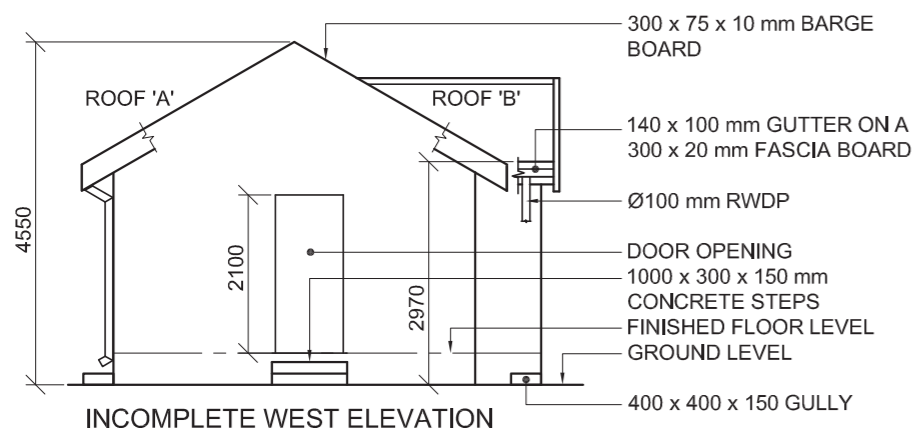

INCOMPLETE WEST ELEVATION

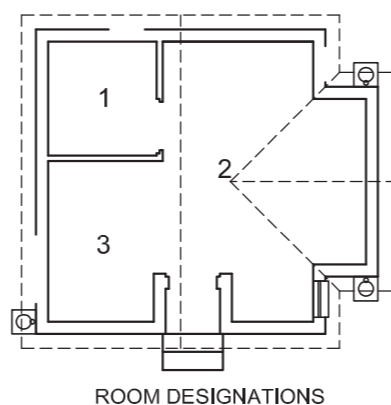

ROOM DESIGNATIONS

FLOOR FINISHES

- 1 BATHROOM: TILE
- 2 LIVING ROOM: CARPET
- 3 KITCHEN: TILE

FEATURES

- D DOOR
- W1 TO W3 WINDOWS

FIXTURES

- WC TOILET
- WB WASHBASIN
- SH SHOWER
- S SINK

ELECTRICAL FITTINGS

- 1. ONE-WAY SWITCH - SINGLE-POLE
- 2. ONE-WAY SWITCH - DOUBLE-POLE
- 3. FLUORESCENT LIGHT 2 x 40 W
- 4. CEILING LIGHT
- 5. SWITCHED SOCKET OUTLET
- 6. DISTRIBUTION BOARD

NOTE:

THE ARROW SHOWS THE LIGHT CONNECTION TO THE SWITCH.

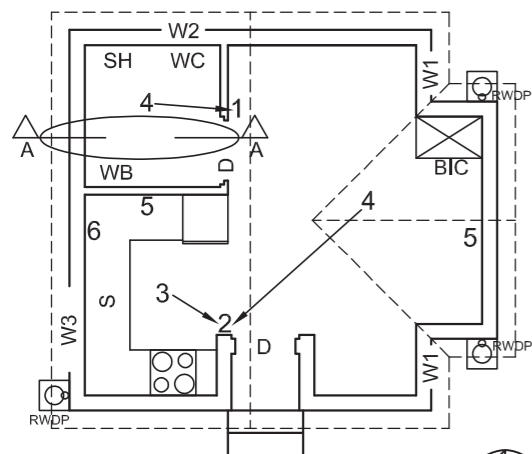

INCOMPLETE FLOOR PLAN

ROOF NOTES:

- 30° ROOF PITCH
- 114 x 38 mm ROOF TRUSS ON 114 x 38 mm WALL PLATES
- 240 mm ROOF OVERHANG TO END OF ROOF TRUSS
- 30 mm CORRUGATED ROOF SHEETING ON 75 x 50 mm PURLINS @ 1000 mm c/c
- 300 x 75 x 10 mm BARGE BOARD ON GABLE ENDS, 20 mm PAST THE GUTTER
- 300 x 20 mm FASCIA BOARD WITH 140 x 100 mm GUTTERS ON ALL SIDES
- 9 mm CEILING BOARD ON 38 x 38 mm BRANDING STRIPS @ 400 mm c/c

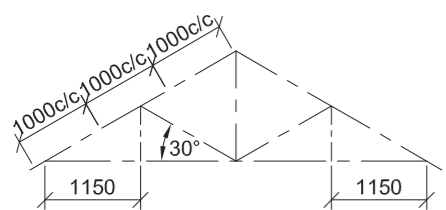

SCHEMATIC DIAGRAM OF A ROOF TRUSS FOR ROOF 'A'

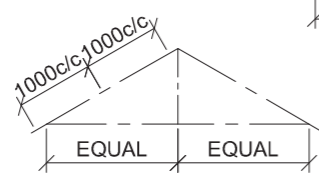

SCHEMATIC DIAGRAM OF A ROOF TRUSS FOR ROOF 'B'

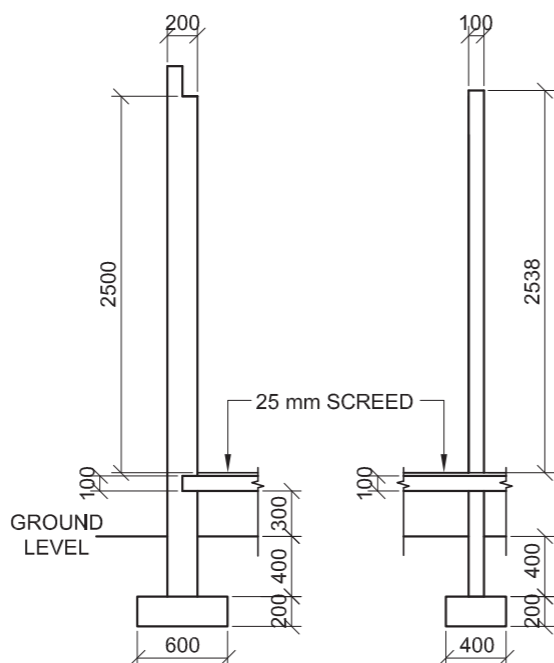

INCOMPLETE WALL AND FOUNDATION DETAIL OF AN EXTERNAL AND AN INTERNAL WALL

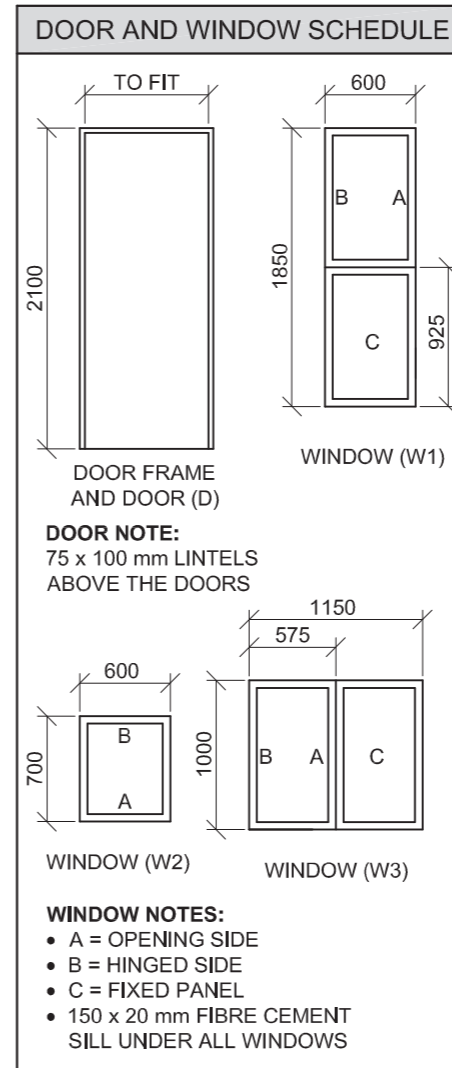
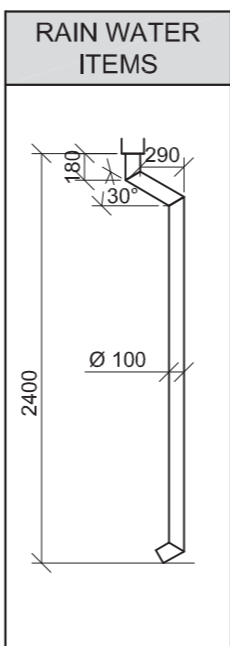
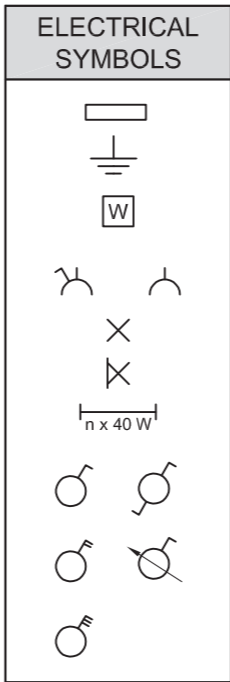

ROOF COMPONENTS	
	ROOF CAP
	114 x 38 mm WALL PLATE
	140 x 100 mm GUTTER

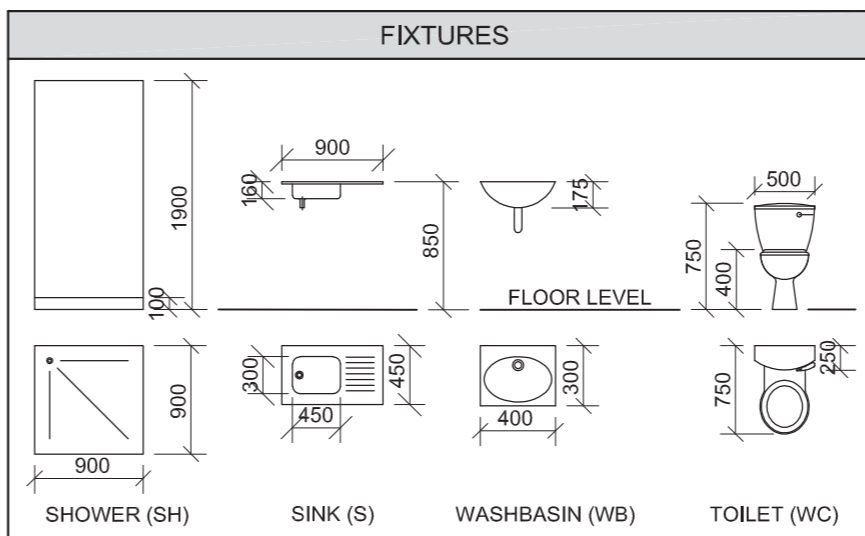

QUESTION 4: CIVIL DRAWING

Given:

- The incomplete west elevation of a **new house** showing the walls, the door and window openings, the roof and notes
- The incomplete floor plan showing the walls, positions of the doors, windows, fixtures and the electrical layout
- Roof notes and a schematic diagram of roof truss 'A' and roof truss 'B'
- Room designations and floor finishes
- The incomplete wall and foundation detail of an external and an internal wall
- A table of electrical symbols
- A table of rain water items
- A door and window schedule
- A table of roof components
- A table of fixtures
- The incomplete floor plan of the **new house**, drawn to scale 1 : 50 and the incomplete foundation of a detailed section, drawn to scale 1 : 20, on page 6

Instructions:

Answer this question on page 6.

4.1 Using the given incomplete floor plan, draw, in first-angle orthographic projection and to scale 1 : 50, the following views of the **new house**:

4.1.1 THE COMPLETE FLOOR PLAN

Add the following features to the drawing:

- ALL doors and windows
- The fixtures as indicated by the abbreviations
- ALL electrical fittings as indicated by the numbers
- ALL hatching detail

4.1.2 THE COMPLETE WEST ELEVATION

Show the following features on the drawing:

- The outside walls, gullies, steps and door detail
- The roof detail, including the barge boards, fascia board, gutter and rainwater down-pipes
- The finished floor level

4.2 Using the incomplete foundation on page 6, draw, to scale 1 : 20, a **DETAILED SECTION** on cutting plane A-A of the area in the ellipse shown on the incomplete floor plan.

Show the following features on the drawing:

- The wall and foundation detail of both walls
- The door detail
- The roof detail, including the fascia board, barge board and gutter
- The shower, toilet and the window above the ellipse
- ALL hatching detail. ONLY the substructure hatching may be drawn in neat freehand.

Label the following:

- The west elevation
- The room designations and floor finishes
- Ground level, finished floor level and damp-proof course (use the correct abbreviations and show it on ALL the relevant views)

NOTE:

ALL drawings must comply with the **guidelines** and **graphical symbols** as contained in the SANS 10143. **[95]**



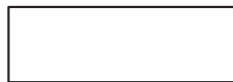
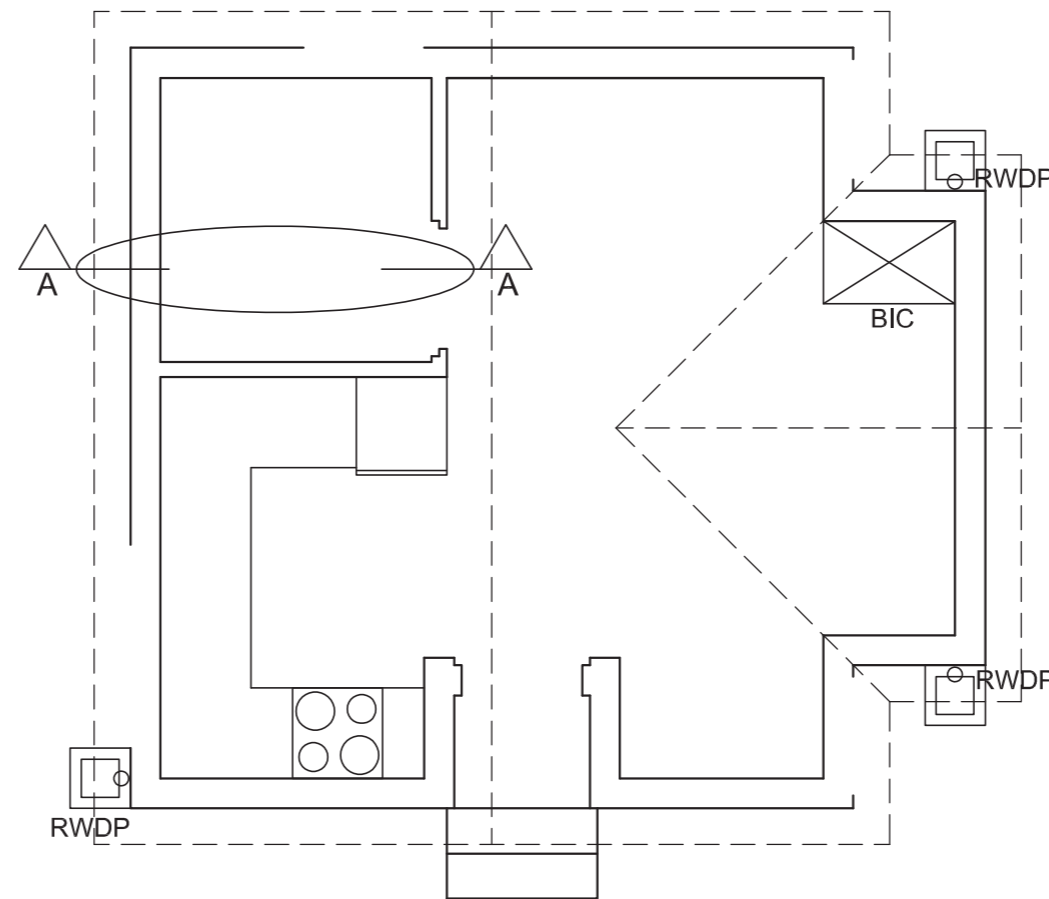

DETAILED SECTION A-A
SCALE 1 : 20

FLOOR PLAN
SCALE 1 : 50



1. MARK ALLOCATION FOR ROOF SECTION		FOR OFFICIAL USE ONLY	
A (1)		INCORRECT SCALE(S) USED	
B (1)		NON-ALIGNMENT OF VIEWS	
C (2)		VIEW(S) ROTATED	
D (5)		SECTION VIEWED INCORRECTLY	
E (2)		INCORRECT LETTERING	
F (1)			
G (1)			
H (1)			
I (1)			
TOTAL		TOTAL	

ASSESSMENT CRITERIA					
FLOOR PLAN					
		POSSIBLE	OBTAINED	SIGN	MODERATED
1	DOORS + WINDOWS	10			
2	ELECTRICAL	6			
3	FIXTURES	8			
4	HATCHING	3			
5	LABELS	3			
SUBTOTAL		30			
WEST ELEVATION					
1	ROOF + RWDP	10			
2	WALLS + FFL	6 1/2			
3	DOOR	2			
4	LABELS	1 1/2			
SUBTOTAL		20			
DETAILED SECTION					
1	ROOF DETAIL	15			
2	FOUNDATION + WALL + DOOR	14 1/2			
3	WC + SHOWER + WINDOW	7			
4	HATCHING	7 1/2			
5	LABELS	1			
SUBTOTAL		45			
TOTAL		95			
PENALTIES (-)					
GRAND TOTAL					
EXAMINATION NUMBER					
					6

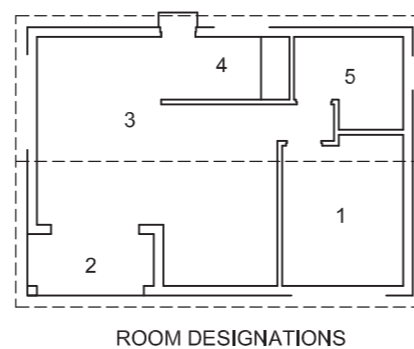
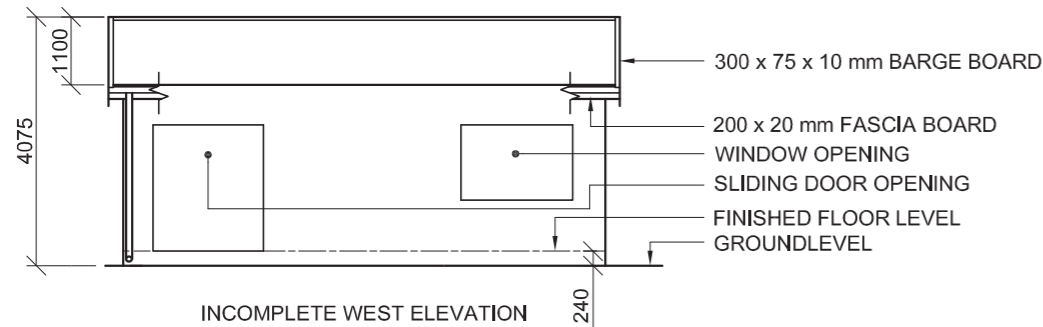

DOOR AND WINDOW SCHEDULE

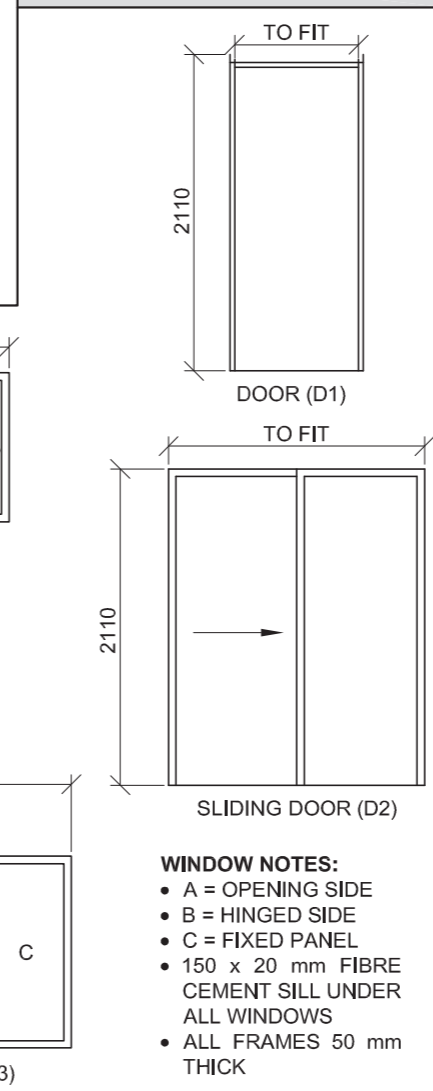

QUESTION 4: CIVIL DRAWING

Given:

- The incomplete west elevation of a **new house** showing the walls, the sliding door and window openings, the roof and notes
- The incomplete floor plan showing the walls, positions of the doors, windows, fixtures and the electrical layout
- A schematic diagram of a roof truss and roof notes
- The incomplete detail of the foundations and walls for the veranda
- Room designations and floor finishes
- A table of electrical symbols
- A door and window schedule
- A table of roof components
- A table of fixtures
- The incomplete floor plan of the **new house**, drawn to scale 1 : 50, and the incomplete foundation and break line of the detailed section, drawn to scale 1 : 20, on page 6

Instructions:

Answer this question on page 6.

4.1 Using the given incomplete floor plan, draw, in first-angle orthographic projection and to scale 1 : 50, the following views of the **new house**:

4.1.1 THE COMPLETE FLOOR PLAN

Add the following features to the drawing:

- ALL doors and windows
- The fixtures as indicated by the abbreviations
- ALL electrical fittings as indicated by the numbers
- ALL hatching detail

4.1.2 THE COMPLETE WEST ELEVATION

Show the following features on the drawing:

- The outside walls, sliding door and window detail
- The veranda detail
- The roof detail, including the roof cap, barge boards, fascia board, gutter and rainwater down-pipe
- The finished floor level

4.2 Using the incomplete foundation and break line on page 6, draw, to scale 1 : 20, a **DETAILED SECTION** on cutting plane C-C of the area in the ellipse shown on the incomplete floor plan.

Show the following features on the drawing:

- The complete detail of the foundations and walls for the veranda
- The door detail
- The roof detail, including the fascia board, gutter and barge board
- ALL hatching detail. ONLY the substructure hatching may be drawn in neat freehand.

Label the following:

- The west elevation
- The room designations and floor finishes
- Ground level, finished floor level and damp-proof course (use the correct abbreviations and show them on ALL the relevant views)

NOTE:

ALL drawings must comply with the **guidelines** and **graphical symbols** as contained in the **SANS 10143**. [93]

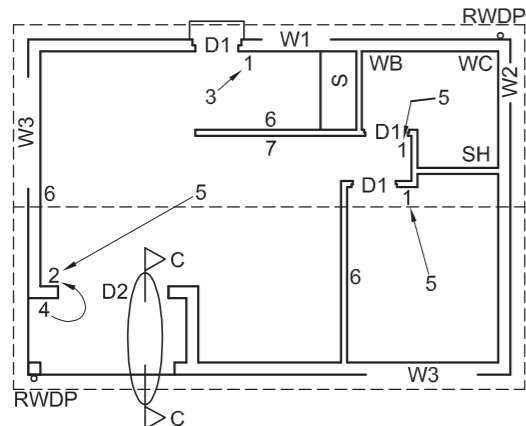

FEATURES

- D1** DOOR
- D2** SLIDING DOOR
- W1 TO W3** WINDOWS

FIXTURES

- WC** TOILET
- WB** WASHBASIN
- SH** SHOWER
- S** SINK

ELECTRICAL FITTINGS

- ONE-WAY SWITCH - SINGLE-POLE
- ONE-WAY SWITCH - DOUBLE-POLE
- FLUORESCENT LIGHT 2 x 40 W
- WALL-MOUNTED LIGHT
- CEILING LIGHT
- SWITCHED SOCKET OUTLET
- DISTRIBUTION BOARD

NOTE:
THE ARROW SHOWS THE LIGHT CONNECTION TO THE SWITCH.

FLOOR FINISHES

- 1. BEDROOM: CARPET
- 2. VERANDA: GRANO
- 3. LIVING AREA: WOOD
- 4. KITCHEN: TILE
- 5. BATHROOM: TILE

ELECTRICAL SYMBOLS

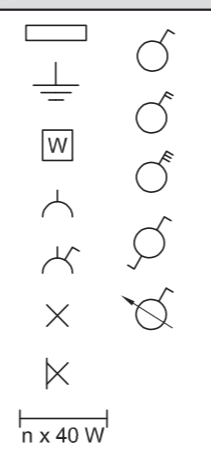

ROOF COMPONENTS

	114 x 38 mm WALL PLATE		300 x 75 x 10 mm FIBRE CEMENT BARGE BOARD
	200 x 20 mm FASCIA BOARD		ROOF CAP

FIXTURES

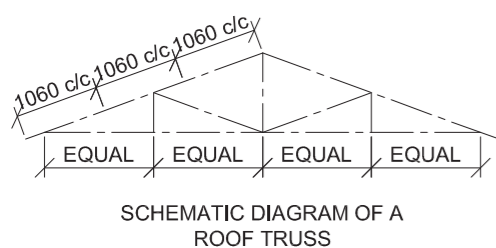
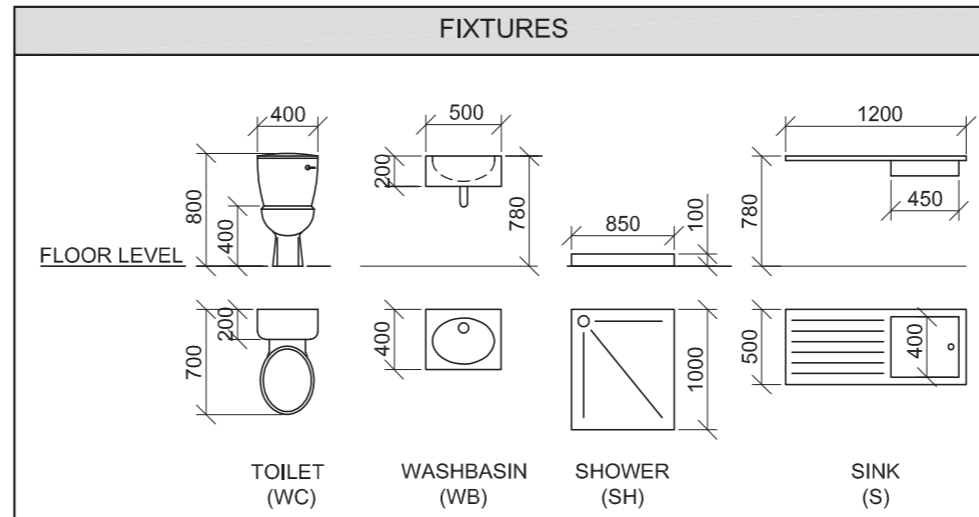

ROOF NOTES:

- 20° ROOF PITCH
- 114 x 38 mm ROOF TRUSSES ON 114 x 38 mm WALL PLATES
- 240 mm ROOF OVERHANG TO END OF ROOF TRUSSES
- 30 mm CORRUGATED ROOF SHEETING ON 75 x 50 mm PURLINS @ 1060 mm c/c
- 300 x 75 x 10 mm BARGE BOARD ON GABLE ENDS, 20 mm PAST THE GUTTER
- 200 x 20 mm FASCIA BOARD ON BOTH SIDES
- 150 x 100 mm GUTTER ON BOTH SIDES WITH Ø100 RAINWATER DOWN-PIPES
- 10 mm CEILING BOARD ON 38 x 38 mm BRANDING STRIPS @ 460 mm c/c

200 x 80 mm LINTELS ABOVE ALL DOORS, WINDOWS AND OPENINGS, ALL AT THE SAME HEIGHT

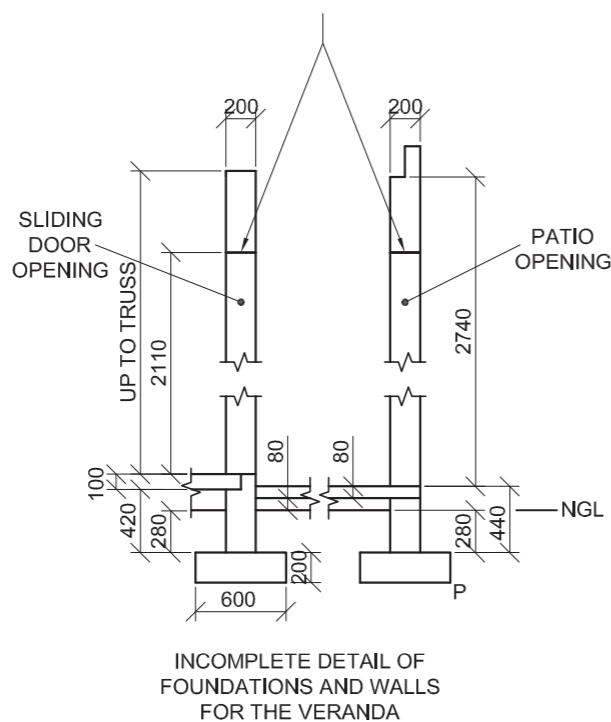

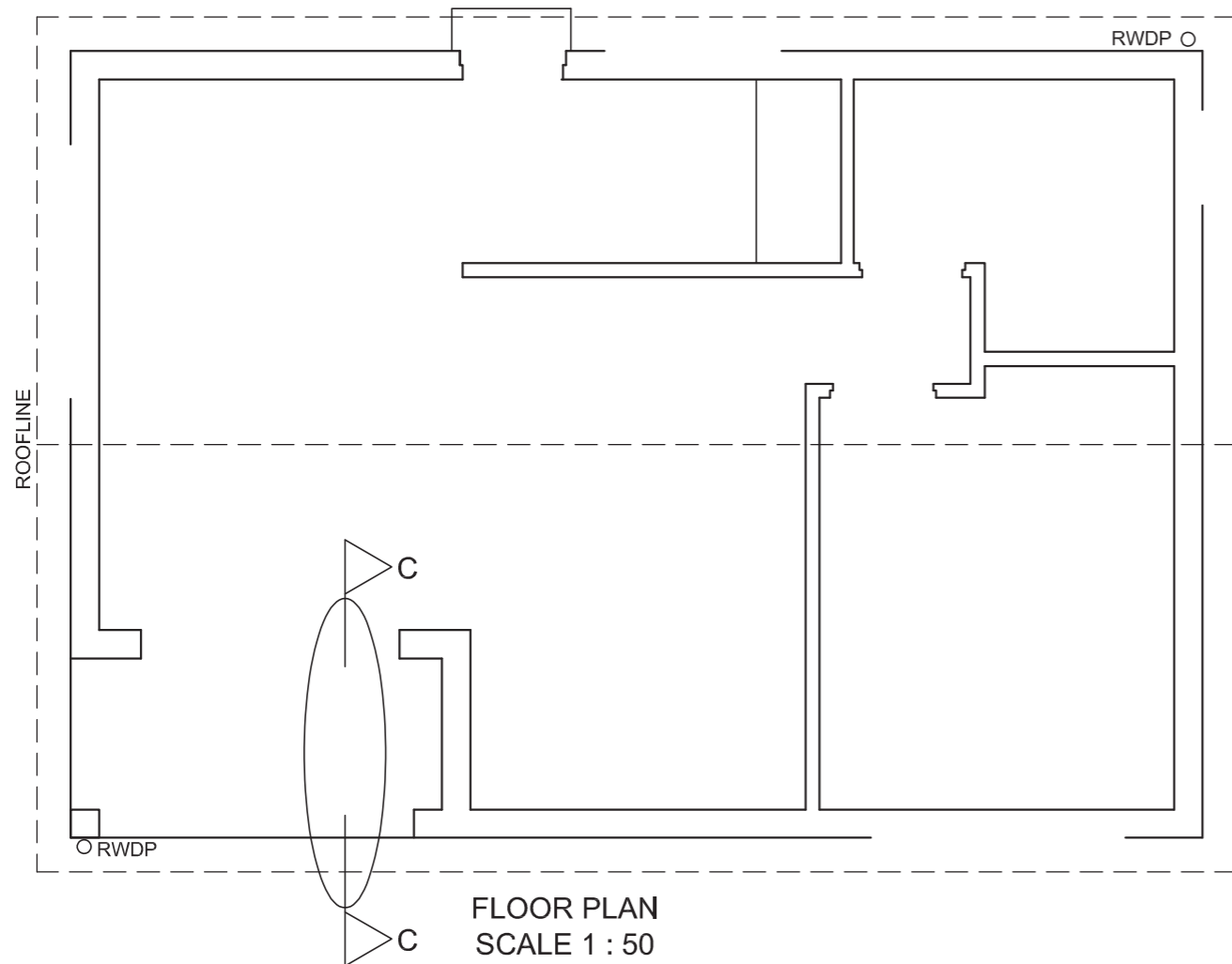

FLOOR PLAN
SCALE 1 : 50

DETAILED SECTION C-C P
SCALE 1 : 20

MARK ALLOCATION FOR ROOF SECTION (4.2)		FOR OFFICIAL USE ONLY	
A (1)		INCORRECT SCALE	
B (1)		NON-ALIGNMENT OF VIEWS	
C (2)		VIEW(S) ROTATED	
D (3)		SECTION VIEWED INCORRECTLY	
E (2)		INCORRECT LETTERING	
F (1)			
G (1)			
H (2)			
I (1)			
J (1)			
TOTAL		TOTAL	

ASSESSMENT CRITERIA					
FLOOR PLAN					
		POSSIBLE	OBTAINED	SIGN	MODERATED
1	DOORS + WINDOWS	13 1/2			
2	FIXTURES	7			
3	ELECTRICAL	9 1/2			
4	HATCHING	4			
5	LABELS	5			
SUBTOTAL		39			
WEST ELEVATION					
1	ROOF + RWDP	5 1/2			
2	WALLS + FFL + STEP	4			
3	DOOR + WINDOW	7 1/2			
4	LABELS	1 1/2			
SUBTOTAL		18 1/2			
DETAILED SECTION					
1	ROOF	12			
2	FOUNDATION + WALL + SLAB + DOOR + LINTEL	13 1/2			
3	HATCHING	9			
4	LABELS	1			
SUBTOTAL		35 1/2			
TOTAL		93			
TOTAL PENALTIES (-)					
GRAND TOTAL					
EXAMINATION NUMBER					
EXAMINATION NUMBER					



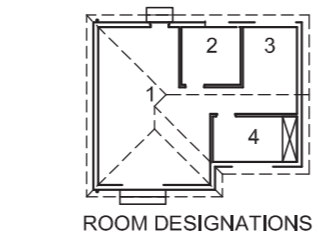
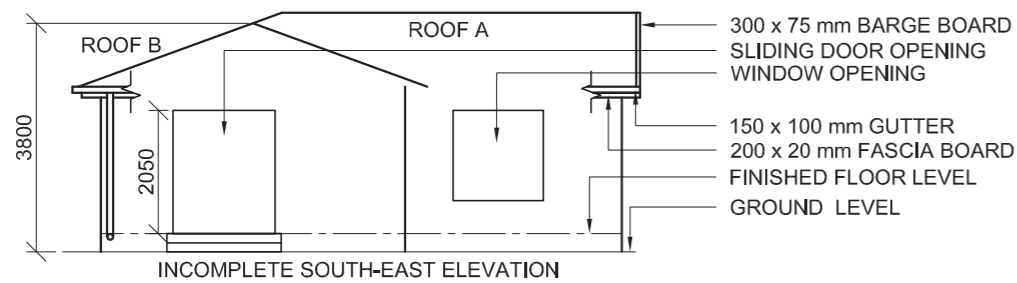

ROOF COMPONENTS	
	300 x 75 mm BARGE BOARD
	200 x 20 mm FASCIA BOARD
	ROOF CAP

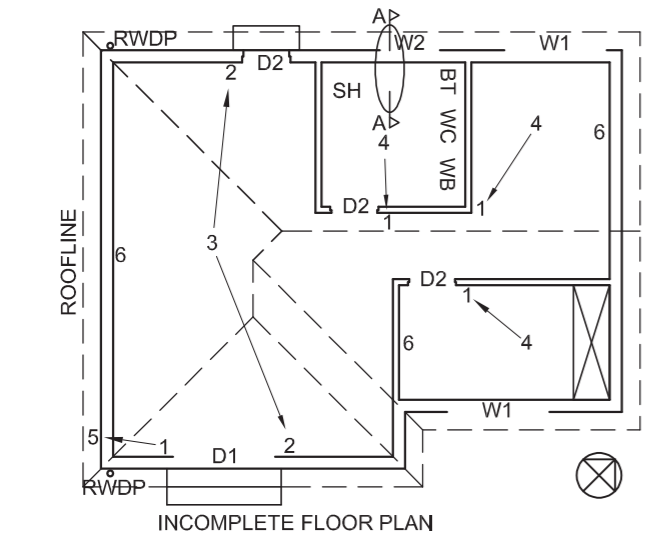

- FEATURES**
D1 SLIDING DOOR
D2 DOOR
W1 AND W2 WINDOWS
- FIXTURES**
WC TOILET
WB WASH BASIN
BT BIDET
SH SHOWER

- FLOOR FINISHES**
 1 LIVING AREA CARPET
 2 BATHROOM TILE
 3 HOBBY ROOM TILE
 4 BEDROOM CARPET

- ELECTRICAL FITTINGS**
 1. ONE-WAY SWITCH - SINGLE POLE
 2. TWO-WAY SWITCH - SINGLE POLE
 3. FLUORESCENT LIGHT 2 x 40 W
 4. CEILING LIGHT
 5. WALL-MOUNTED LIGHT
 6. SWITCHED SOCKET OUTLET

NOTE:
 THE ARROW SHOWS THE LIGHT CONNECTION TO THE SWITCH.

ELECTRICAL SYMBOLS		

QUESTION 4: CIVIL DRAWING

- Given:**
- The incomplete south east elevation of a **new house**, showing the walls, the sliding door and window openings, the roof and notes
 - The incomplete floor plan showing the walls, positions of steps, doors, windows, fixtures and the electrical layout
 - Schematic diagrams of the roof trusses and roof notes
 - The incomplete foundation and external wall detail
 - Room designations and floor finishes
 - A table of roof components
 - A table of electrical symbols
 - A door and window schedule
 - A table of fixtures
 - The incomplete floor plan of the **new house**, drawn to scale 1 : 50, and the incomplete foundation and the breakline of the detailed section, drawn to scale 1 : 20, on page 6

Instructions:
 Answer this question on page 6.

4.1 Using the given incomplete floor plan, draw, in first-angle orthographic projection and to scale 1 : 50 the following views of the **new house**:

4.1.1 THE COMPLETE FLOOR PLAN
 Add the following features to the drawing:

- ALL doors and windows
- ALL fixtures as indicated by the abbreviations
- ALL electrical fittings as indicated by the numbers
- ALL hatching detail

4.1.2 THE COMPLETE SOUTH-EAST ELEVATION
 Show the following features on the drawing:

- The outside walls, sliding door, steps and window detail
- The roof detail, including the fascia boards, gutters, barge board, roof cap and rainwater downpipe
- The finished floor level

4.2 Using the incomplete foundation and breakline on page 6, draw, to scale 1 : 20, a **DETAILED SECTION** on cutting plane A-A of the area in the ellipse shown on the incomplete floor plan.

Show the following features on the drawing:

- The complete foundation and external wall detail
- The window detail
- The roof detail, including the fascia board, gutter and barge board
- The bidet
- ALL hatching detail. ONLY the substructure hatching may be drawn in neat freehand.

Label the following:

- The south-east elevation
- The room designations and floor finishes
- Ground level, finished floor level, damp-proof course and built-in cupboard (use the correct abbreviations and show them on all the relevant views)

NOTE:
 ALL drawings must comply with the **guidelines** and **graphical symbols** as contained in the *SANS 10143*. [95]

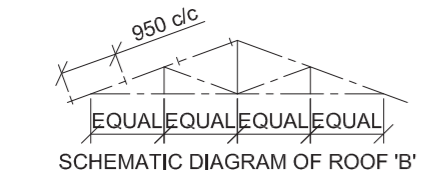
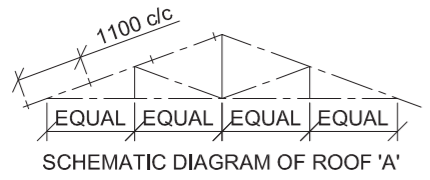

- ROOF NOTES:**
 20° ROOF PITCH
 114 x 38 mm ROOF TRUSSES ON
 114 x 38 mm WALL PLATES
- 300 mm ROOF OVERHANG TO END OF ROOF TRUSSES
- 10 mm FIBRE CEMENT ROOF SHEETING ON 75 x 50 mm PURLINS SPACED ACCORDING TO SCHEMATIC DIAGRAMS
- 200 x 20 mm FASCIA BOARD ON ALL SIDES AND 300 x 75 mm BARGE BOARDS ON THE GABLED END, 20 mm PAST THE GUTTER
- 150 x 100 mm GUTTERS WITH Ø75 RWDP ON ALL SIDES
- 10 mm CEILING BOARDS ON 38 x 38 mm BRANDING STRIPS @ 450 c/c

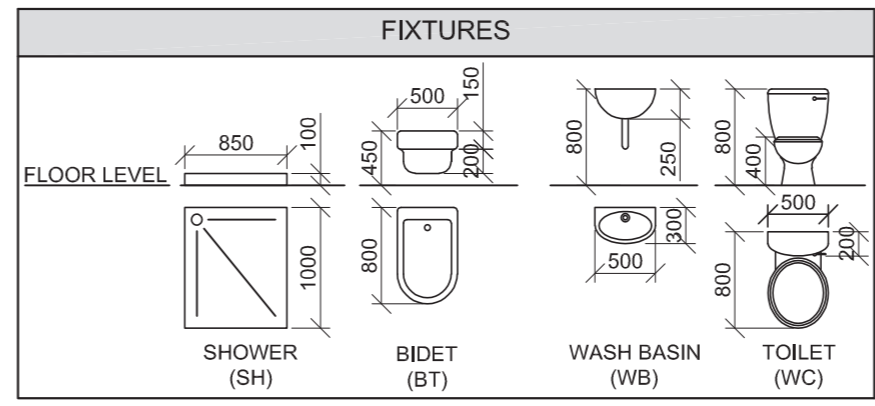
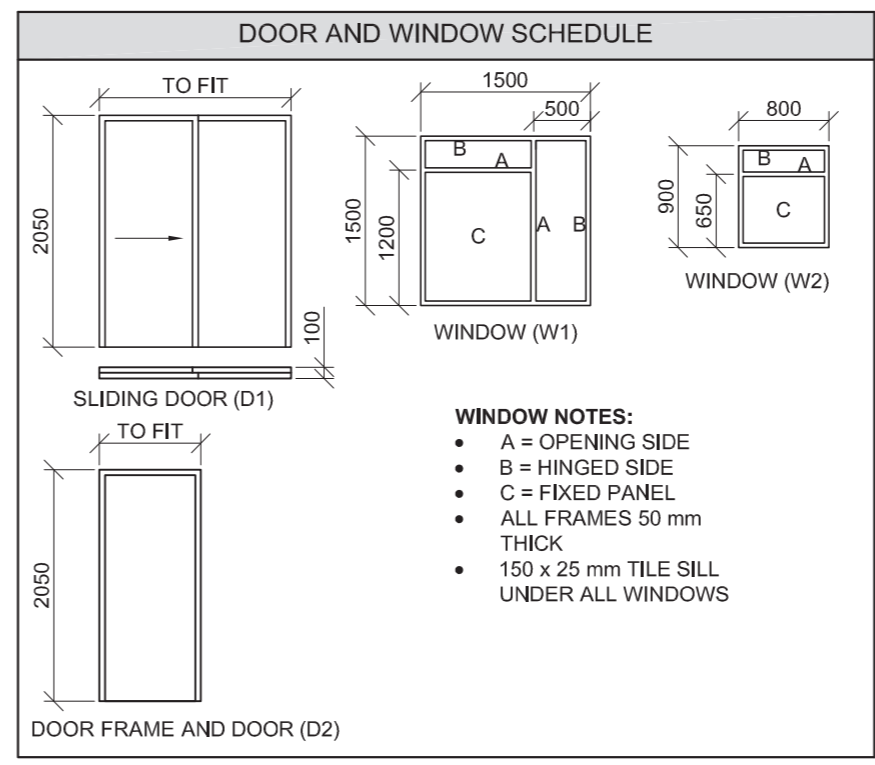
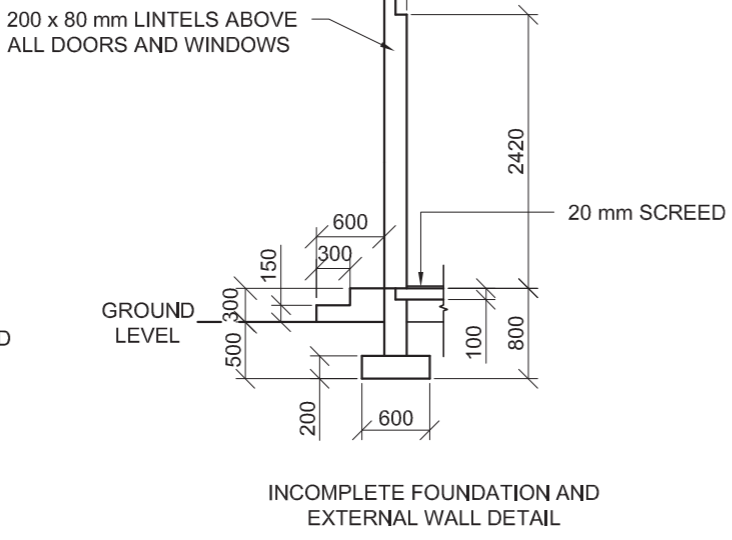

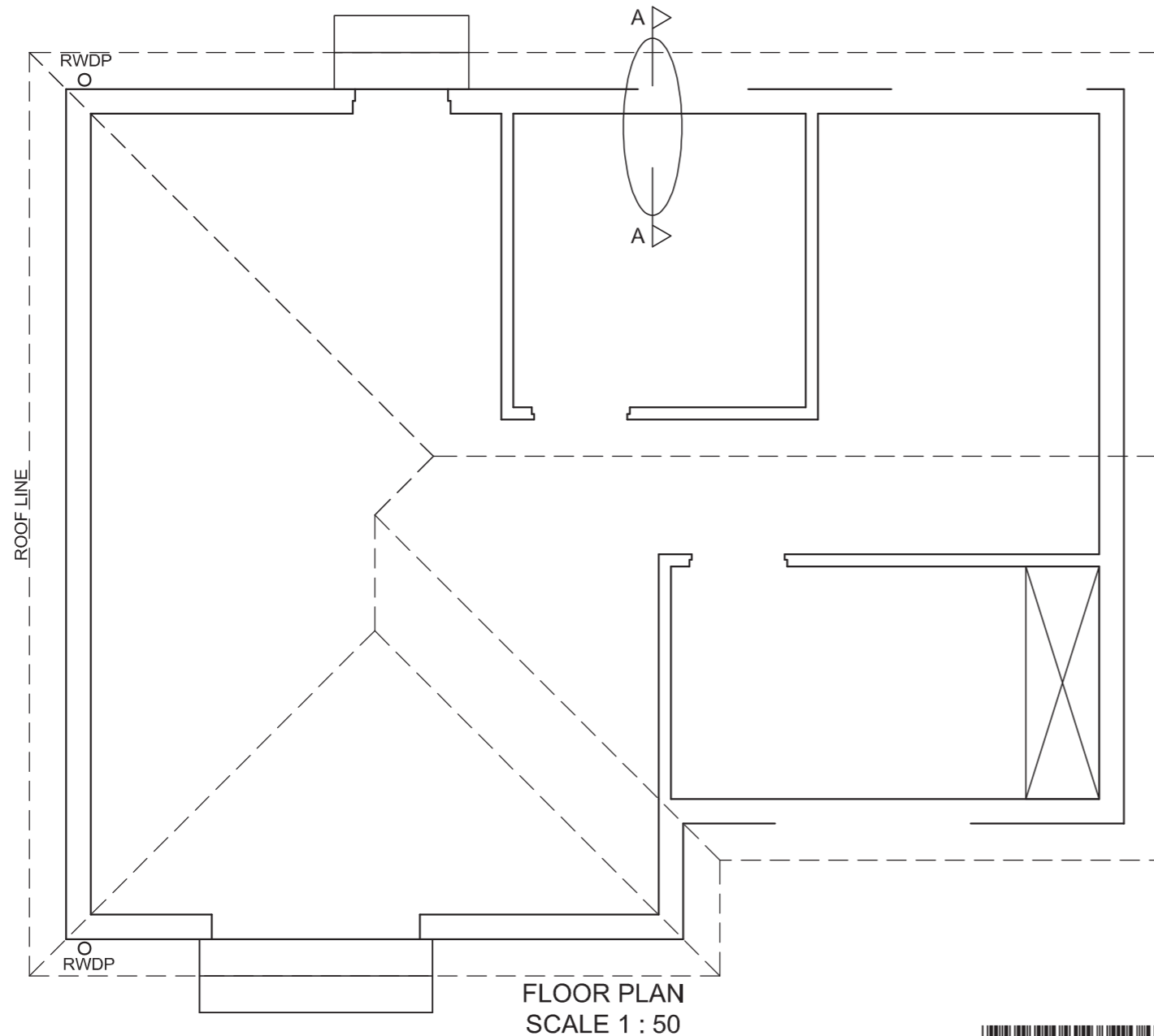

SECTION A - A
SCALE 1 : 20

1. MARK ALLOCATION FOR ROOF SECTION		FOR OFFICIAL USE ONLY	
A (1)		INCORRECT SCALE(S) USED	
B (1)		NON-ALIGNMENT OF VIEWS	
C (2)		VIEW(S) ROTATED	
D (3)		SECTION VIEWED INCORRECTLY	
E (2)		INCORRECT LETTERING	
F (1)			
G (1)			
H (1)			
I (1)			
TOTAL		TOTAL	

ASSESSMENT CRITERIA				
FLOOR PLAN				
		POSSIBLE	OBTAINED	SIGN
1	DOORS + WINDOWS	11		
2	FIXTURES	7		
3	ELECTRICAL	10 1/2		
4	HATCHING	4		
5	LABELS	4 1/2		
SUBTOTAL		37		
SOUTH EAST ELEVATION				
1	ROOF + RWDP	9 1/2		
2	WALLS + FFL + STEPS	4 1/2		
3	DOOR + WINDOW	8		
4	LABELS	1 1/2		
SUBTOTAL		23 1/2		
DETAILED SECTION				
1	ROOF DETAIL	13		
2	FOUNDATION + WALL + SLAB	7		
3	WINDOW + SILL	3 1/2		
4	FIXTURES	3 1/2		
5	HATCHING	6		
6	LABELS	1 1/2		
SUBTOTAL		34 1/2		
TOTAL		95		
PENALTIES (-)				
GRAND TOTAL				
EXAMINATION NUMBER				
EXAMINATION NUMBER				
				6



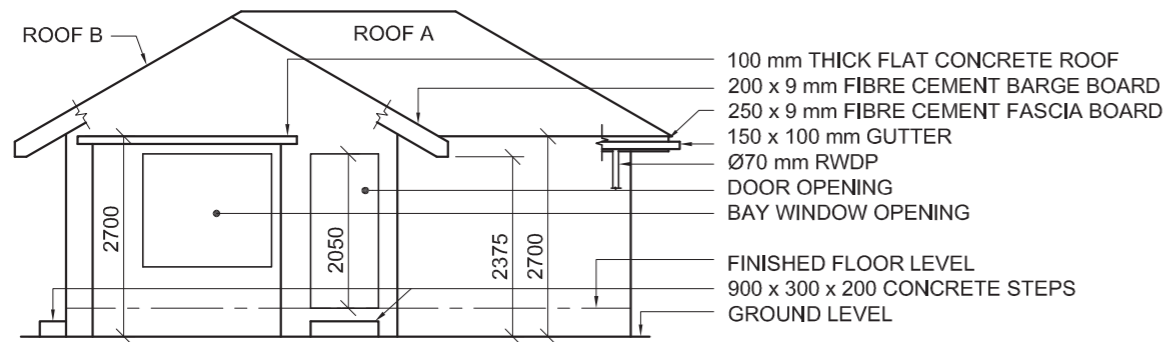

INCOMPLETE WEST ELEVATION

- 100 mm THICK FLAT CONCRETE ROOF
- 200 x 9 mm FIBRE CEMENT BARGE BOARD
- 250 x 9 mm FIBRE CEMENT FASCIA BOARD
- 150 x 100 mm GUTTER
- Ø70 mm RWDP
- DOOR OPENING
- BAY WINDOW OPENING
- FINISHED FLOOR LEVEL
- 900 x 300 x 200 CONCRETE STEPS
- GROUND LEVEL

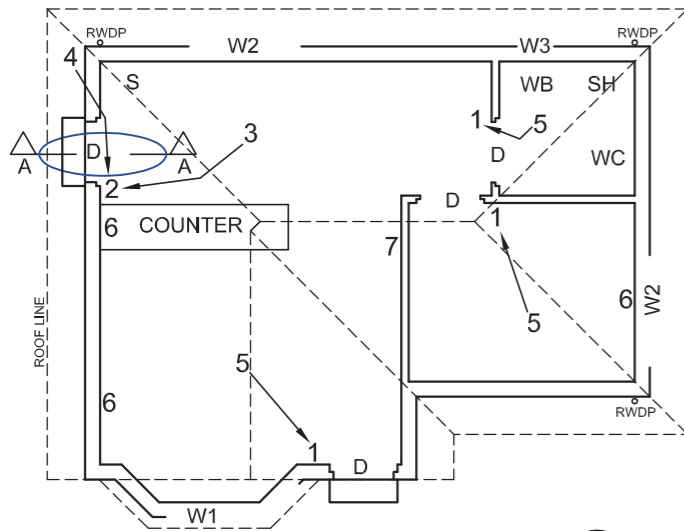

INCOMPLETE FLOOR PLAN

- FEATURES**
- D DOOR
 - W1 TO W3 WINDOWS

- FIXTURES**
- WC TOILET
 - WB WASHBASIN
 - SH SHOWER
 - S SINK

- ELECTRICAL FITTINGS**
1. ONE-WAY SWITCH - SINGLE-POLE
 2. ONE-WAY SWITCH - DOUBLE-POLE
 3. FLUORESCENT LIGHT 3 x 40 W
 4. WALL-MOUNTED LIGHT
 5. CEILING LIGHT
 6. SWITCHED SOCKET OUTLET
 7. DISTRIBUTION BOARD

NOTE:
THE ARROW SHOWS THE LIGHT CONNECTION TO THE SWITCH.

ROOF NOTES:

- 30° ROOF PITCH
- 114 x 38 mm ROOF TRUSS ON 114 x 38 mm WALL PLATES
- 500 mm ROOF OVERHANG TO END OF ROOF TRUSS
- 10 mm FIBRE CEMENT ROOF SHEETING ON 75 x 50 mm PURLINS @ 1000 mm c/c
- 200 x 9 mm BARGE BOARD ON GABLE ENDS
- 250 x 9 mm FASCIA BOARD WITH 150 x 100 mm GUTTERS ON ALL SIDES
- 9 mm CEILING BOARD ON 38 x 38 mm BRANDING STRIPS @ 400 mm c/c

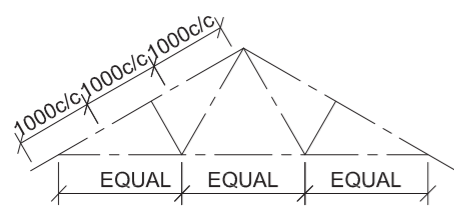

SCHEMATIC DIAGRAM OF A ROOF TRUSS FOR ROOF B

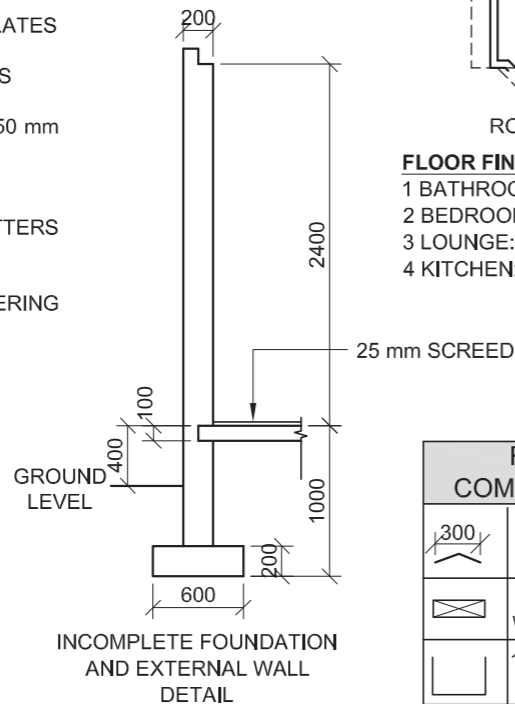

INCOMPLETE FOUNDATION AND EXTERNAL WALL DETAIL

- FLOOR FINISHES**
- 1 BATHROOM: TILE
 - 2 BEDROOM: CARPET
 - 3 LOUNGE: CARPET
 - 4 KITCHEN: TILE

ROOF COMPONENTS	
	ROOF CAP
	114 x 38 mm WALL PLATE
	150 x 100 mm GUTTER

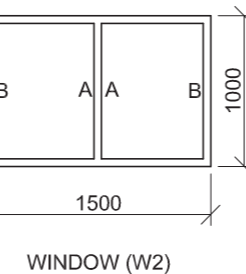
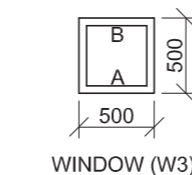
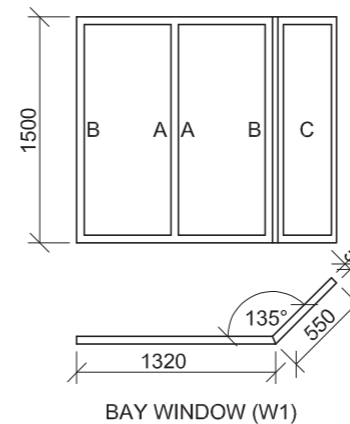
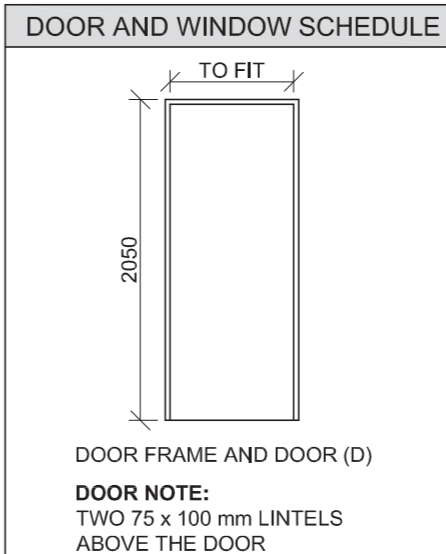
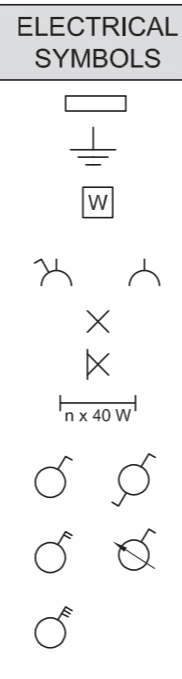

- WINDOW NOTES:**
- A = OPENING SIDE
 - B = HINGED SIDE
 - C = FIXED PANEL
 - 150 x 20 mm FIBRE CEMENT SILL UNDER ALL WINDOWS

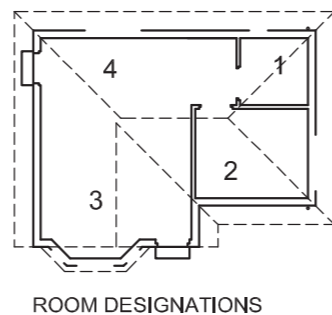

ROOM DESIGNATIONS

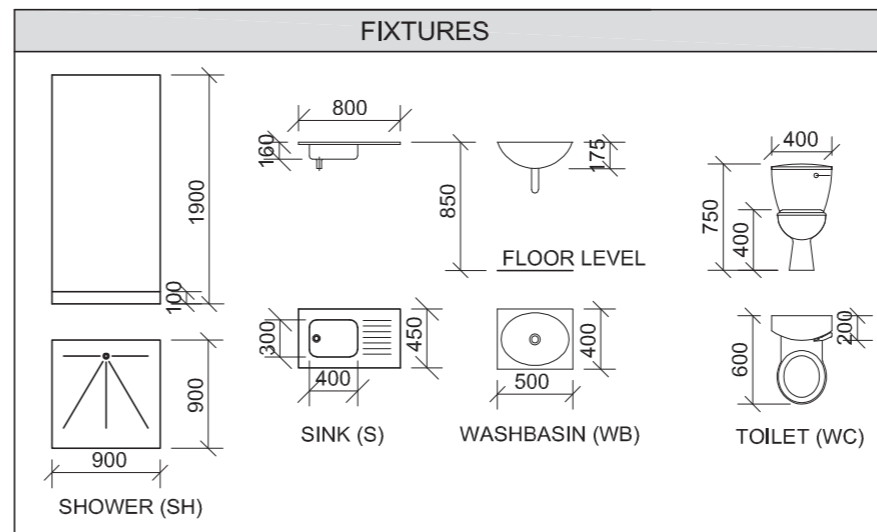

QUESTION 4: CIVIL DRAWING

Given:

- The incomplete west elevation of a **new house**, showing the walls, the door and window openings, the roof and notes
- The incomplete floor plan showing the walls, positions of the doors, windows, fixtures and the electrical layout
- A schematic diagram of a roof truss and roof notes
- Room designations and floor finishes
- The incomplete foundation and external wall detail
- A table of roof components
- A table of electrical symbols
- A door and window schedule
- A table of fixtures
- The incomplete floor plan of the **new house**, drawn to scale 1 : 50, and the incomplete foundation of the detailed section, drawn to scale 1 : 20, on page 6

Instructions:

Answer this question on page 6.

4.1 Using the given incomplete floor plan, draw, in first-angle orthographic projection and to scale 1 : 50, the following views of the **new house**:

4.1.1 THE COMPLETE FLOOR PLAN

Add the following features to the drawing:

- ALL doors and windows
- The fixtures as indicated by the abbreviations
- ALL electrical fittings as indicated by the numbers
- ALL hatching detail

4.1.2 THE COMPLETE WEST ELEVATION

Show the following features on the drawing:

- The outside walls, door and window detail
- The roof detail, including the barge boards, fascia boards, gutters and rainwater down-pipe
- The finished floor level

4.2 Using the incomplete foundation on page 6, draw, to scale 1 : 20, a **DETAILED SECTION** on cutting plane A-A of the area in the ellipse shown on the incomplete floor plan.

Show the following features on the drawing:

- The foundation and external wall detail
- The door detail
- The roof detail, including the fascia board and gutter
- The sink
- ALL hatching detail. ONLY the substructure hatching may be drawn in neat freehand.

Label the following:

- The west elevation
- The room designations and floor finishes
- Ground level, finished floor level and damp-proof course (use the correct abbreviations and show it on ALL the relevant views)

NOTE:

ALL drawings must comply with the **guidelines** and **graphical symbols** as contained in the **SANS 10143**. [95]



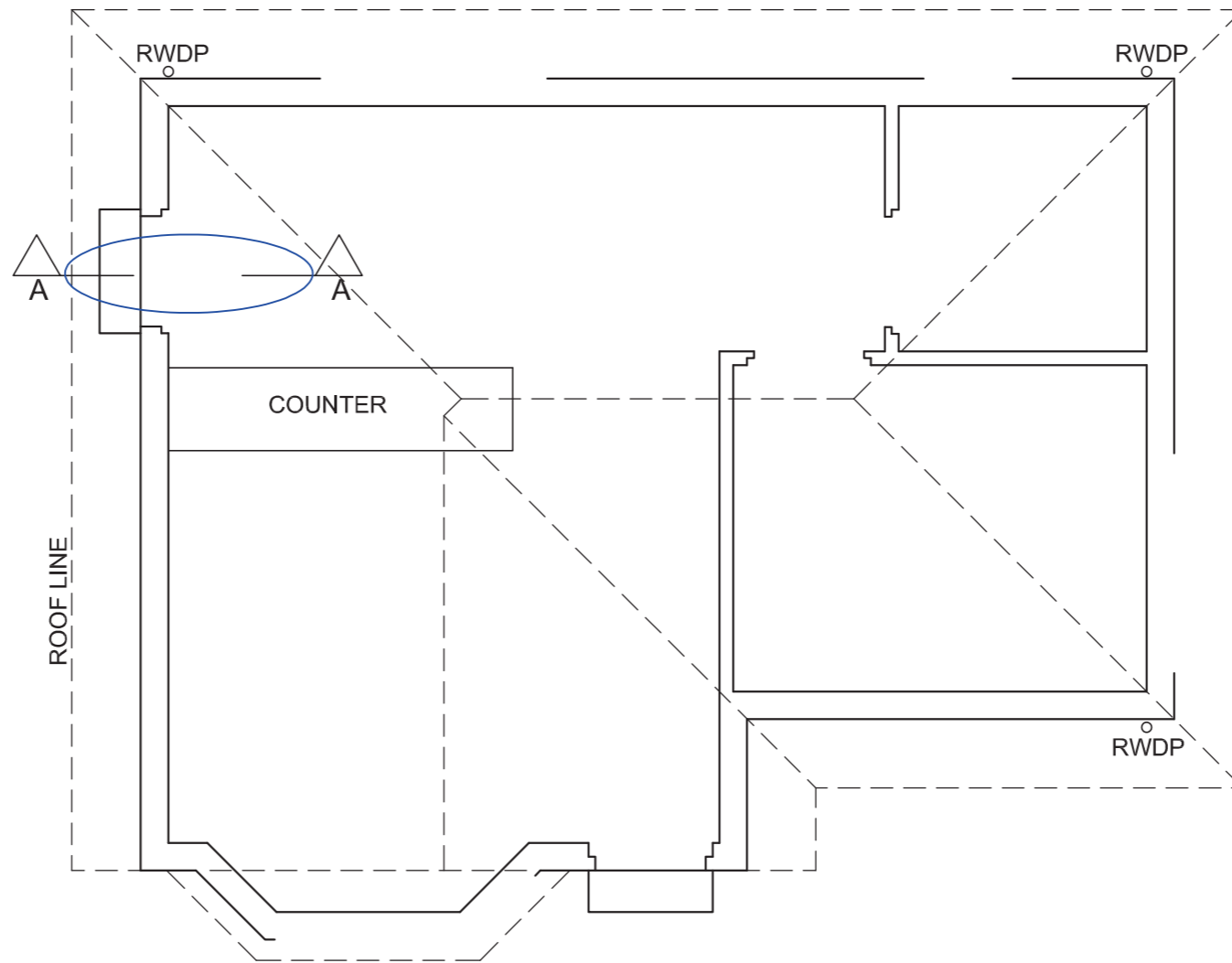

DETAILED SECTION A-A
SCALE 1 : 20

FLOOR PLAN
SCALE 1 : 50

FOR OFFICIAL USE ONLY	
INCORRECT SCALE	
NON-ALIGNMENT OF VIEWS	
VIEW(S) ROTATED	
SECTION VIEWED INCORRECTLY	
INCORRECT LETTERING	
TOTAL	

MARK ALLOCATION FOR ROOF SECTION										
A	B	C	D	E	F	G	H	I	J	

ASSESSMENT CRITERIA					
FLOOR PLAN					
		POSSIBLE	OBTAINED	SIGN	MODERATED
1	DOORS + WINDOWS	13½			
2	ELECTRICAL	9½			
3	FIXTURES	8½			
4	HATCHING	3			
5	LABELS	4			
SUBTOTAL		38½			

WEST ELEVATION					
		POSSIBLE	OBTAINED	SIGN	MODERATED
1	ROOF + RWDP	12			
2	WALLS + FFL	6½			
3	DOOR + WINDOW	8			
4	LABELS	1½			
SUBTOTAL		28			

DETAILED SECTION					
		POSSIBLE	OBTAINED	SIGN	MODERATED
1	ROOF DETAIL	11			
2	FOUNDATION + WALL + DOOR	9			
3	SINK	3			
4	HATCHING	4½			
5	LABELS	1			
SUBTOTAL		28½			
TOTAL		95			

PENALTIES (-)					
GRAND TOTAL					
EXAMINATION NUMBER					
EXAMINATION NUMBER					



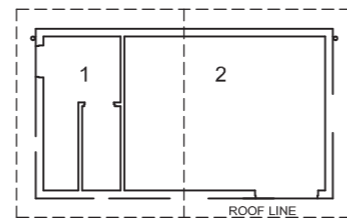
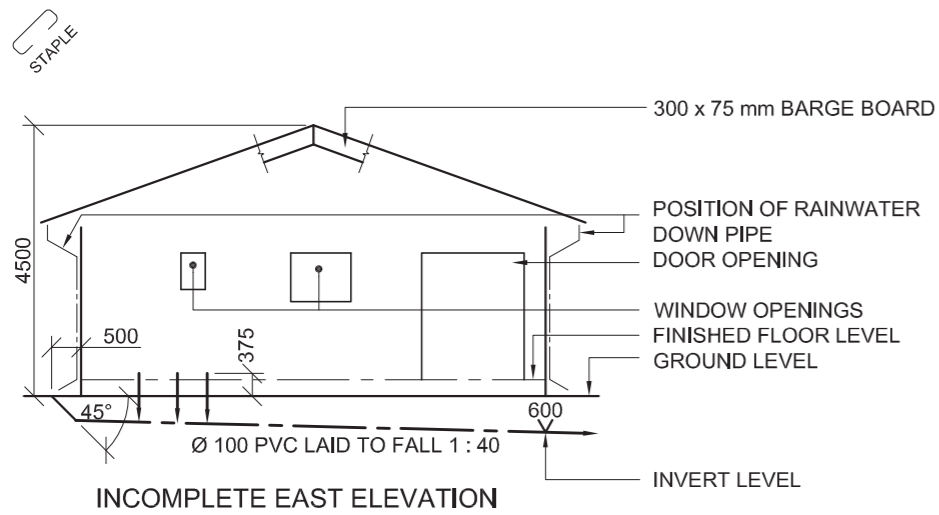

ROOM DESIGNATIONS

FLOOR FINISHES
 1. TOILET: TILE
 2. CHANGE ROOM: TILE

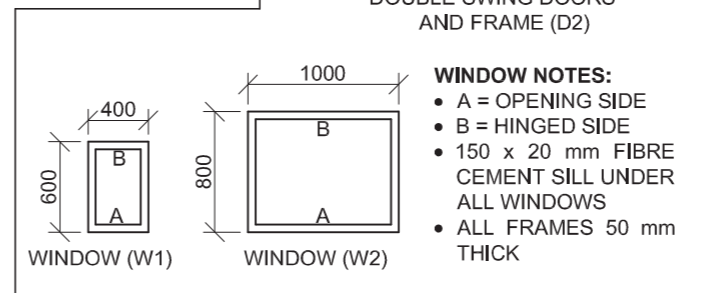
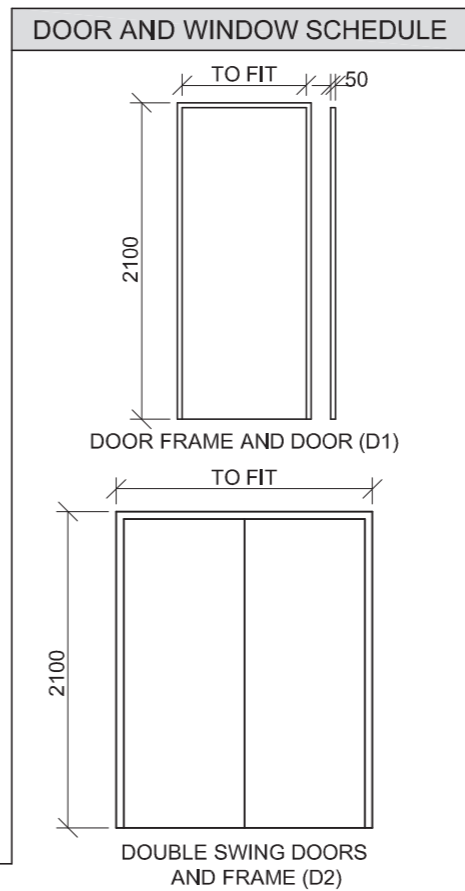
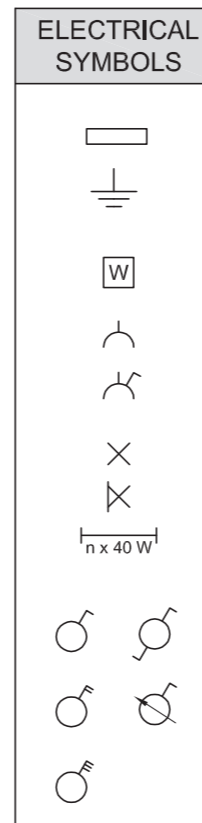

ROOF COMPONENTS

	114 x 38 mm WALL PLATE		300 x 75 x 9 mm FIBRE CEMENT BARGE BOARD
	220 x 20 mm FASCIA BOARD		ROOF CAP

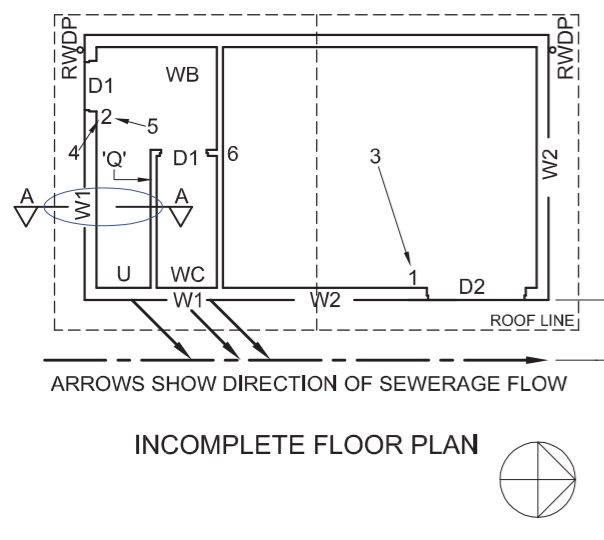
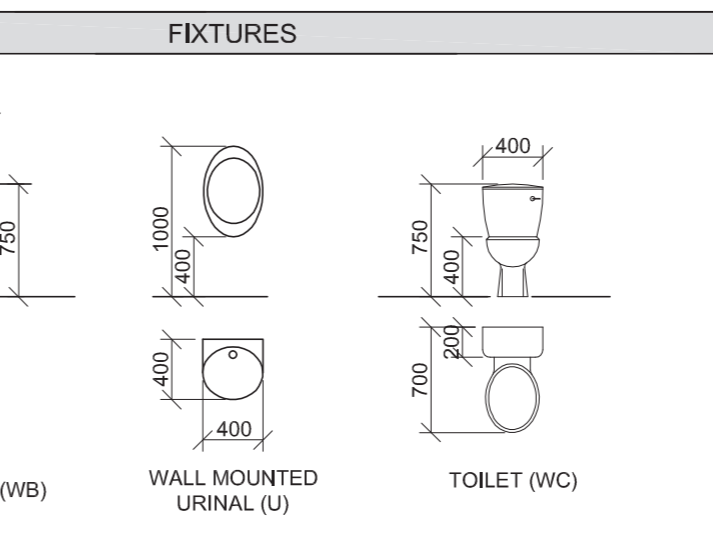

FEATURES
 D1 DOOR
 D2 DOUBLE DOOR
 W1 & W2 WINDOWS

FIXTURES
 WC TOILET
 WB WASH BASIN
 U SINGLE WALL-MOUNTED URINAL

ELECTRICAL FITTINGS
 1. ONE-WAY SWITCH - SINGLE-POLE
 2. ONE-WAY SWITCH - DOUBLE-POLE
 3. FLUORESCENT LIGHT 4 x 40 W
 4. WALL-MOUNTED LIGHT
 5. CEILING LIGHT
 6. SWITCHED SOCKET OUTLET

NOTE:
 THE ARROW SHOWS THE LIGHT CONNECTION TO THE SWITCH.

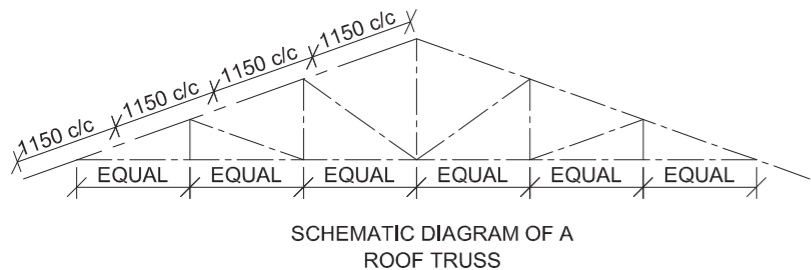

ROOF NOTES:
 ROOF PITCH 20°
 114 x 38 mm ROOF TRUSS ON 114 x 38 mm WALL PLATES
 500 mm ROOF OVERHANG TO END OF ROOF TRUSS
 30 mm CORRUGATED ROOF SHEETING ON 75 x 50 mm PURLINS @ 1150 mm c/c
 300 x 75 x 9 mm BARGE BOARD ON GABLE ENDS AND 220 x 20 mm FASCIA BOARD ON BOTH SIDES
 100 x 150 mm GUTTER ON BOTH SIDES
 9 mm CEILING BOARD ON 38 x 38 mm BRANDING STRIPS @ 450 mm c/c

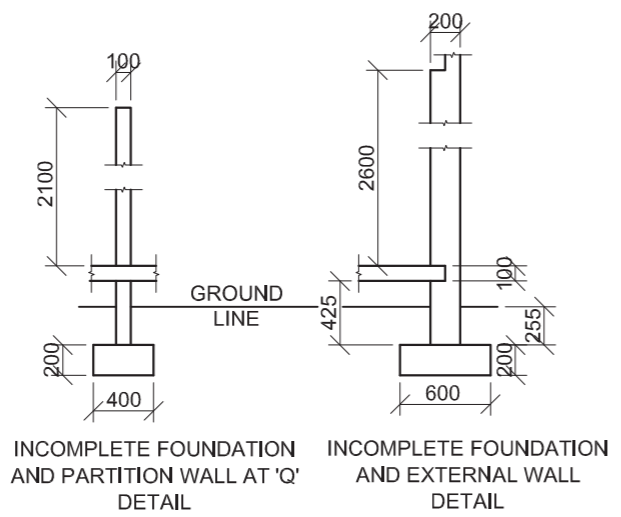

QUESTION 4: CIVIL DRAWING

Given:

- The incomplete east elevation of a **new change room and toilet** showing the walls, the door and window openings, the roof and notes
- The incomplete floor plan showing the walls, positions of the doors, windows, fixtures and the electrical layout
- Schematic diagram of a roof truss and roof notes
- The incomplete foundation and wall detail
- Room designations and floor finishes
- A table of rainwater items
- A table of electrical symbols
- A door and window schedule
- A table of roof components
- A table of fixtures
- The incomplete floor plan of the **new change room and toilet**, drawn to scale 1 : 50, and the incomplete foundation of the external wall, drawn to scale 1 : 20, on page 6

Instructions:

Answer this question on page 6.

4.1 Using the given incomplete floor plan, draw, in first-angle orthographic projection and to scale 1 : 50, the following views of the **new change room and toilet**:

4.1.1 THE COMPLETE FLOOR PLAN

Add the following features to the drawing:

- ALL doors and windows
- The fixtures as indicated by the abbreviations
- ALL electrical fittings as indicated by the numbers
- The sewer lines
- ALL hatching detail

4.1.2 THE COMPLETE EAST ELEVATION

Show the following features on the drawing:

- The outside walls, door and window detail
- The roof detail, including the barge boards and the rainwater down-pipes
- The finished floor level
- The sewer line

4.2 Using the incomplete foundation, draw, to **scale 1 : 20**, a **DETAILED SECTION** on cutting plane A-A of the area in the ellipse shown on the incomplete floor plan.

Show the following features on the drawing:

- The complete foundation and external wall detail
- The complete foundation and partition wall detail
- The window detail
- The roof detail, including the fascia board, gutter, rainwater down-pipe and barge board
- ALL features and fixtures in front of the section
- ALL hatching detail. **ONLY** the substructure hatching may be drawn in neat freehand.

Label the following:

- The east elevation
- The room designations and floor finishes
- Ground level, finished floor level, rodding eye and damp-proof course (use the correct abbreviations and show it on ALL the relevant views)

NOTE:

ALL drawings must comply with the **guidelines** and **graphical symbols** as contained in the **SANS 10143. [92]**



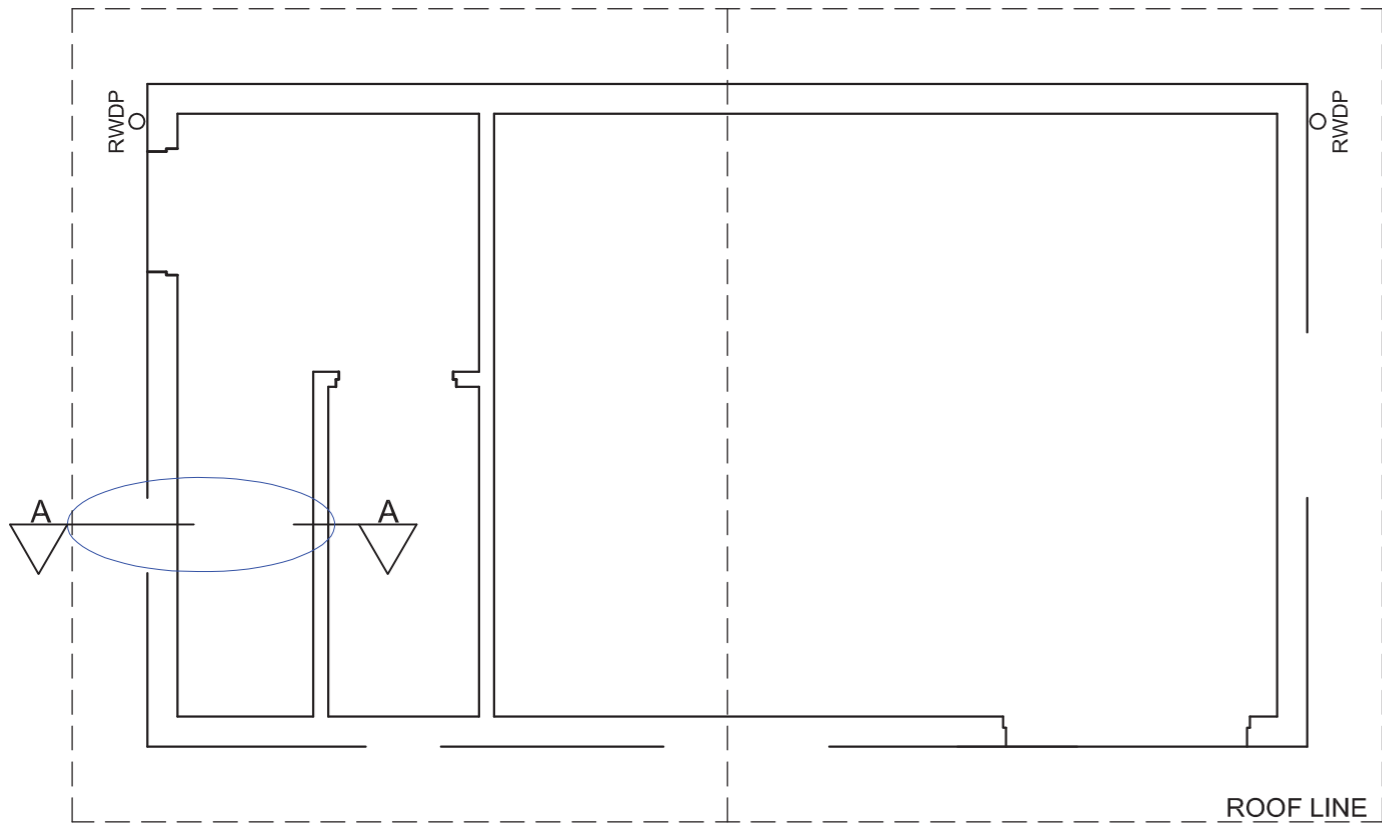

FLOOR PLAN
SCALE 1 : 50

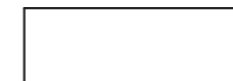

DETAILED SECTION A-A
SCALE 1 : 20

FOR OFFICIAL USE ONLY				
INCORRECT SCALE				
EAST ELEVATION NOT ALIGNED				
VIEW(S) ROTATED				
SECTION VIEWED INCORRECTLY				
INCORRECT LETTERING				
PENALTIES TOTAL (-)				
MARK ALLOCATION FOR ROOF SECTION (4.2)				
A	B	C	D	E
F	G	H	I	J
K				
ASSESSMENT CRITERIA				
FLOOR PLAN				
		POSSIBLE	OBTAINED	SIGN
				MODERATED
1	DOORS + WINDOWS	12		
2	ELECTRICAL	5		
3	FIXTURES	6		
4	HATCHING	3		
5	LABELS	2 1/2		
6	PLUMBING	2		
SUBTOTAL		30 1/2		
EAST ELEVATION				
1	ROOF + RWDP	6 1/2		
2	WALLS + FFL	2 1/2		
3	DOOR + WINDOW	9 1/2		
4	LABELS	2		
5	PLUMBING	3		
SUBTOTAL		23 1/2		
DETAILED SECTION				
1	ROOF DETAIL + RWDP	13		
2	FOUNDATION + WALL + SLAB	13		
3	URINAL	2 1/2		
4	HATCHING	6		
5	LABELS	1 1/2		
6	WINDOW	2		
SUBTOTAL		38		
TOTAL		92		
PENALTY (-)				
GRAND TOTAL				
EXAMINATION NUMBER				
				6
EXAMINATION NUMBER				
				6



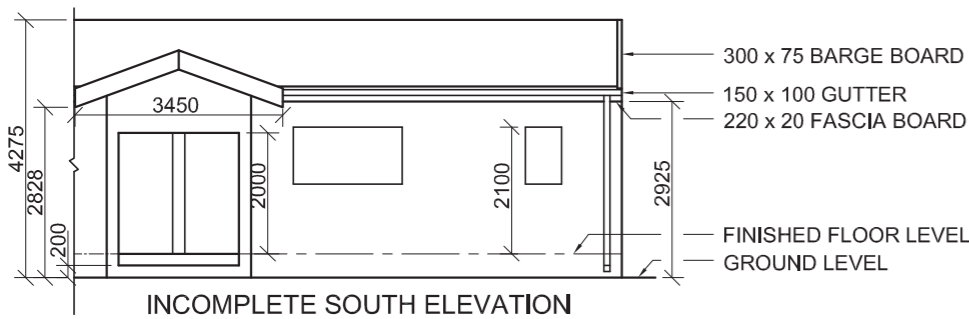

INCOMPLETE SOUTH ELEVATION

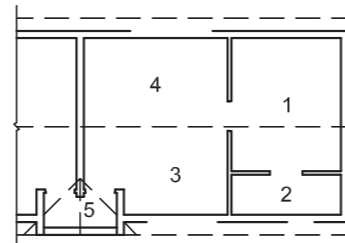

ROOM DESIGNATIONS

FLOOR FINISHES

- | | |
|-------------|--------|
| 1 BEDROOM: | CARPET |
| 2 BATHROOM: | TILE |
| 3 KITCHEN: | TILE |
| 4 LOUNGE: | TILE |
| 5 ENTRANCE: | TILE |

ELECTRICAL SYMBOLS					

QUESTION 4: CIVIL DRAWING

Given:

- The incomplete south elevation of the eastern unit and entrance of a **new cluster house**, showing the walls, the door and window openings, the roof and notes
- The incomplete floor plan showing the walls, positions of the doors, windows, fixtures and electrical layout
- Roof notes, a table of roof components and a schematic diagram of a roof truss
- Room designations and floor finishes
- The incomplete wall and foundation detail
- The rainwater down-pipe
- A table of electrical symbols
- A door and window schedule
- A table of fixtures
- The incomplete floor plan of the eastern unit and entrance of the **new cluster house**, drawn to scale 1 : 50, and the incomplete external wall foundation and the break line of the detailed section, drawn to scale 1 : 20, on page 6

Instructions:

Answer this question on page 6.

4.1 Using the given incomplete floor plan, draw, in first-angle orthographic projection and to scale 1 : 50, the following views of the given eastern unit and entrance of the **new cluster house**:

4.1.1 THE COMPLETE FLOOR PLAN

Add the following features to the drawing:

- ALL doors and windows
- ALL fixtures as indicated by the abbreviations
- ALL electrical fittings as indicated by the numbers
- ALL hatching detail

4.1.2 THE COMPLETE SOUTH ELEVATION

Show the following features on the drawing:

- The outside walls, windows and door detail
- The roof detail, including the fascia board, barge boards, gutter and rainwater down-pipe
- The finished floor level

4.2 Using the incomplete foundation and break line on page 6, draw, to **scale 1 : 20**, a **DETAILED SECTION** on cutting plane A-A of the area in the ellipse shown on the incomplete floor plan.

Show the following features on the drawing:

- The wall and foundation detail of the internal and external wall
- The window detail
- The roof detail, including the fascia board, gutter and rainwater down-pipe
- ALL features and fixtures to the right (east) of the ellipse
- ALL hatching detail. **ONLY** the substructure hatching may be drawn in neat freehand.

Label the following:

- The south elevation
- The room designations and floor finishes
- Ground level, finished floor level and damp-proof course (use the correct abbreviations and show it on ALL the relevant views)

NOTE:

ALL drawings must comply with the **guidelines** and **graphical symbols** contained in the **SANS 10143**. [97]

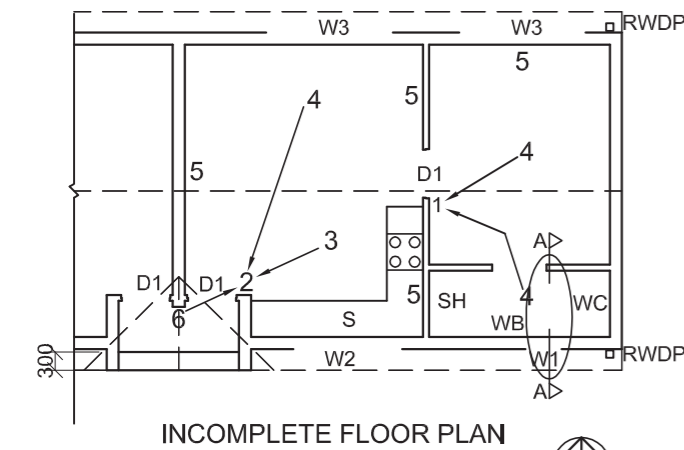

INCOMPLETE FLOOR PLAN

FEATURES

- D1 DOOR
W1 WINDOW
W2 WINDOW
W3 WINDOW

FIXTURES

- WC TOILET
WB WASH BASIN
SH SHOWER
S SINK

ELECTRICAL FITTINGS

- 1 ONE-WAY SWITCH - DOUBLE-POLE
2 ONE-WAY SWITCH - THREE-POLE
3 FLUORESCENT LIGHT 2 x 40 W
4 CEILING LIGHT
5 SWITCHED SOCKET OUTLET
6 WALL-MOUNTED LIGHT

NOTE:

THE ARROW SHOWS THE LIGHT CONNECTION TO THE SWITCH.

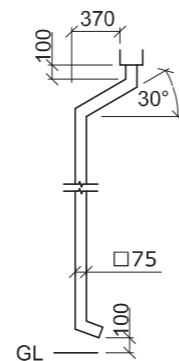

RAINWATER DOWN-PIPE

DOOR AND WINDOW SCHEDULE	
<p>WINDOW (W1)</p>	<p>DOOR FRAME AND DOOR (D1)</p>
<p>WINDOW (W2)</p>	
<p>WINDOW (W3)</p>	<p>WINDOW NOTES:</p> <ul style="list-style-type: none"> • A = OPENING SIDE • B = FIXED PANEL • ALL FRAMES 50 mm • 150 x 20 mm FIBRE CEMENT SILL UNDER ALL WINDOWS

ROOF NOTES:

ROOF PITCH 20°

115 x 38 mm ROOF TRUSSES ON 115 x 38 mm WALL PLATES

ROOF OVERHANG 350 mm TO END OF ROOF TRUSSES

ROOF COVER 15 mm FIBRE CEMENT SHEETING ON 75 x 50 mm PURLINS @ 1000 mm c/c

220 x 20 mm FASCIA BOARD ON ALL SIDES AND 300 x 75 mm BARGE BOARD ON GABLED ENDS

150 x 100 mm GUTTERS ON ALL SIDES

9 mm CEILING BOARD ON 38 x 38 mm BRANDING STRIPS @ 450 mm c/c

ROOF COMPONENTS	
	300 x 75 mm BARGE BOARD
	220 x 20 mm FASCIA BOARD

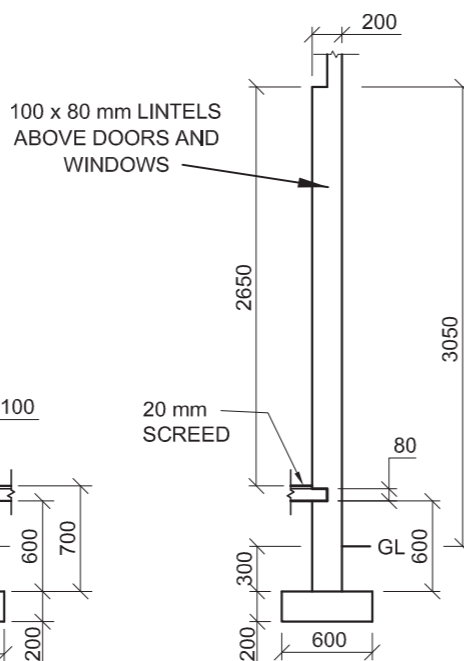

INCOMPLETE WALL AND FOUNDATION DETAIL OF AN INTERNAL AND EXTERNAL WALL

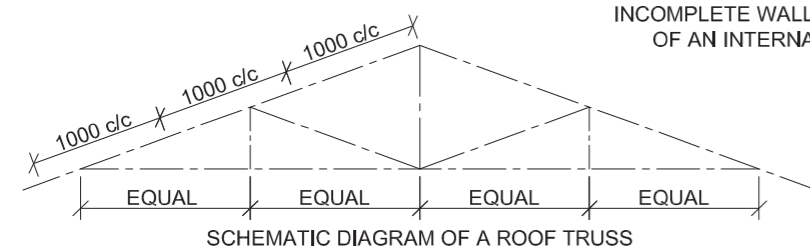

SCHEMATIC DIAGRAM OF A ROOF TRUSS

FIXTURES			
<p>WASH BASIN (WB)</p>	<p>TOILET (WC)</p>	<p>SHOWER (SH)</p>	<p>SINK (S)</p>



STAPLE

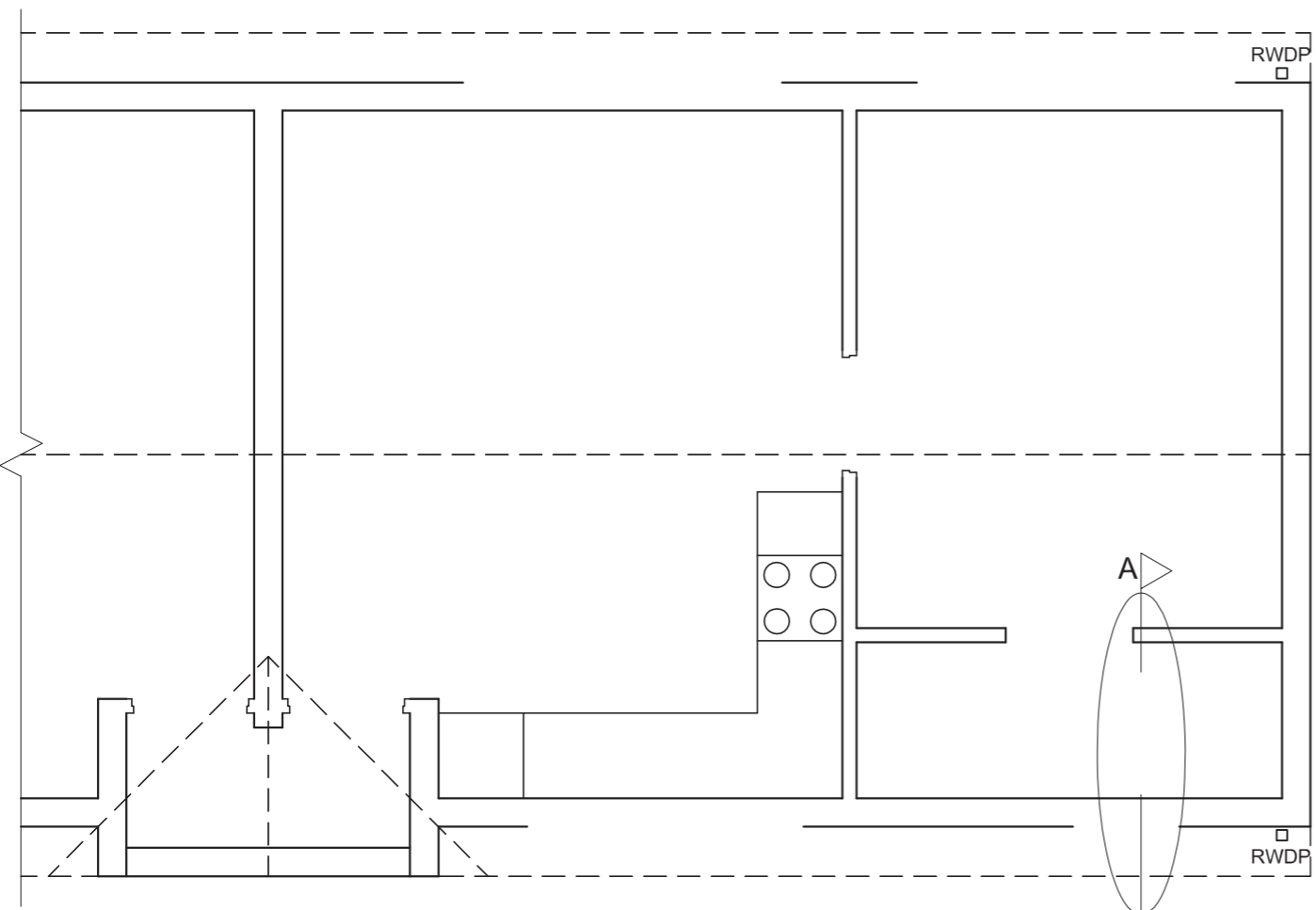

FLOOR PLAN
SCALE 1 : 50

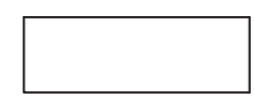

SECTION A-A
SCALE 1 : 20

1. MARK ALLOCATION FOR SECTION OF ROOF		FOR OFFICIAL USE ONLY	
A (1)		INCORRECT SCALE	
B (1)		INCORRECT POSITIONING OF VIEWS	
C (2)		ROTATED VIEWS	
D (3)		PRINTED CAPITAL LETTERS	
E (1)			
F (1)			
G (1)			
H (1)			
I (3)			
TOTAL		TOTAL	

ASSESSMENT CRITERIA			
FLOOR PLAN			
1	DOORS + WINDOWS	11	
2	ELECTRICAL	8 1/2	
3	FIXTURES	7 1/2	
4	HATCHING	4	
5	LABELS	4	
SUBTOTAL		35	
SOUTH ELEVATION			
1	ROOF	6 1/2	
2	WALLS + RWDP + FFL + GUTTER	7 1/2	
3	DOORS + WINDOWS	11 1/2	
4	LABELS	1	
SUBTOTAL		26 1/2	
DETAILED SECTION			
1	ROOF	14	
2	FOUNDATIONS + WALLS + SLAB	13 1/2	
3	WINDOW + LINTELS	3 1/2	
4	FIXTURE	3	
5	LABELS	1 1/2	
SUBTOTAL		35 1/2	
TOTAL		97	
PENALTIES (-)			
GRAND TOTAL			
EXAMINATION NUMBER			
EXAMINATION NUMBER			6



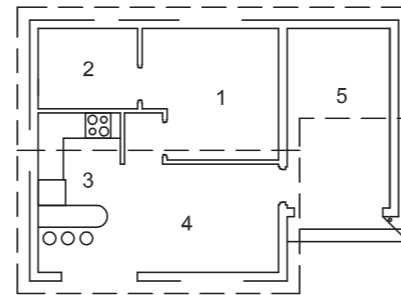
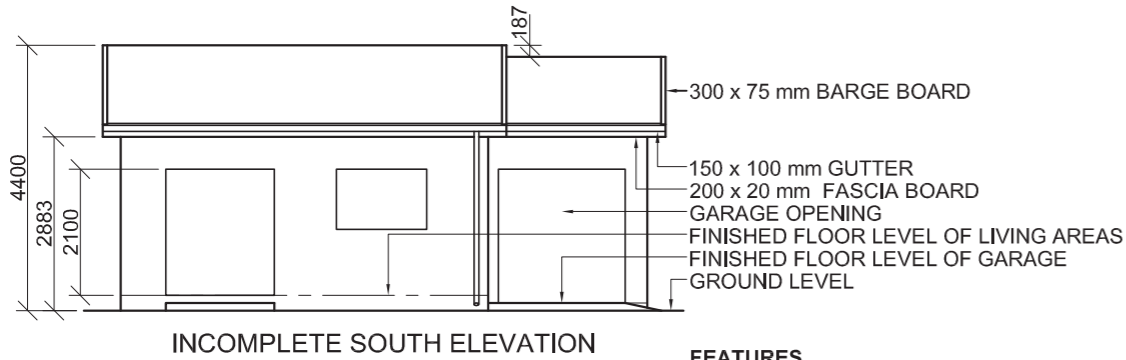

ROOF COMPONENTS	
	300 x 75 mm BARGE BOARD
	220 x 20 mm FASCIA BOARD

QUESTION 4: CIVIL DRAWING

Given:

- The incomplete south elevation of a **new house**, showing the walls, the door, window and garage openings, the roof and notes
- The incomplete floor plan showing the walls, positions of the doors, windows, fixtures and the electrical layout
- A schematic diagram of a roof truss and roof notes
- The incomplete foundation and external wall details of the living areas and the garage
- Room designations and floor finishes
- The rainwater down-pipe
- A table of roof components
- A table of electrical symbols
- A door and window schedule
- A table of fixtures
- The incomplete floor plan of the **new house**, drawn to scale 1 : 50, and the incomplete foundation and the break line of the detailed section, drawn to scale 1 : 20, on page 6

Instructions:

Answer this question on page 6.

4.1 Using the given incomplete floor plan, draw, in first-angle orthographic projection and to scale 1 : 50, the following views of the **new house**:

4.1.1 THE COMPLETE FLOOR PLAN

Add the following features to the drawing:

- ALL doors and windows
- ALL fixtures as indicated by the abbreviations
- ALL electrical fittings as indicated by the numbers
- ALL hatching detail

4.1.2 THE COMPLETE SOUTH ELEVATION

Show the following features on the drawing:

- The outside walls, door and window details and the garage opening
- The roof detail, including the fascia boards, barge boards, gutters and rainwater down-pipes
- The finished floor level

4.2 Using the incomplete foundation and break line on page 6, draw, to **scale 1 : 20**, a **DETAILED SECTION** on cutting plane A-A of the area in the ellipse shown on the incomplete floor plan.

Show the following features on the drawing:

- The foundation, wall and garage opening detail
- The roof detail, including the fascia board and gutter
- ALL the external features of the **new house** to the left (west) of the ellipse
- ALL hatching detail. ONLY the substructure hatching may be drawn in neat freehand.

Label the following:

- The south elevation
- The room designations and floor finishes
- Ground level (use the correct abbreviation and show it on ALL the relevant views)

NOTE:

ALL drawings must comply with the **guidelines** and **graphical symbols** contained in the **SANS 10143**. [93]

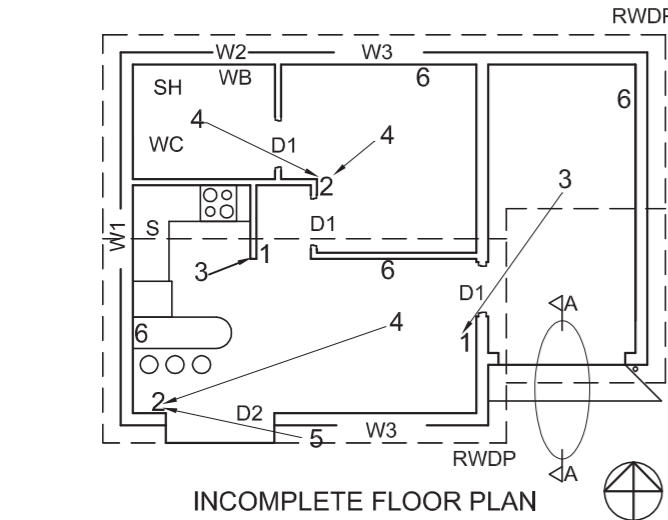

- FEATURES**
 D1 DOOR
 D2 SLIDING DOOR
 W1 WINDOW
 W2 WINDOW
 W3 WINDOW

- FIXTURES**
 WC TOILET
 WB WASH BASIN
 SH SHOWER
 S SINK

- ELECTRICAL FITTINGS**
 1. ONE-WAY SWITCH - SINGLE-POLE
 2. ONE-WAY SWITCH - DOUBLE-POLE
 3. FLUORESCENT LIGHT 2 x 40 W
 4. CEILING LIGHT
 5. WALL-MOUNTED LIGHT
 6. SWITCHED SOCKET OUTLET

NOTE:
 THE ARROW SHOWS THE LIGHT CONNECTION TO THE SWITCH.

ROOM DESIGNATIONS

- FLOOR FINISHES**
 1 BEDROOM: CARPET
 2 BATHROOM: TILE
 3 KITCHEN: TILE
 4 LOUNGE/DINING ROOM: WOOD
 5 GARAGE: GRANO

ELECTRICAL SYMBOLS	

DOOR AND WINDOW SCHEDULE		

- WINDOW NOTES:**
- A = OPENING SIDE
 - B = FIXED PANEL
 - ALL FRAMES 40 mm
 - 150 x 20 mm FIBRE CEMENT SILL UNDER ALL WINDOWS

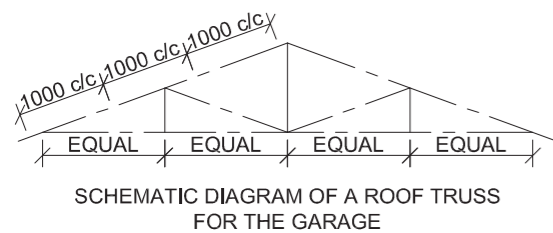

ROOF NOTES:
 ROOF PITCH 20°

115 x 38 mm ROOF TRUSSES ON
 115 x 38 mm WALL PLATES

ROOF OVERHANG 300 mm TO END OF
 ROOF TRUSSES

ROOF COVER 40 mm IBR SHEETING ON
 75 x 50 mm PURLINS @ 1000 mm c/c

220 x 20 mm FASCIA BOARD ON ALL
 SIDES AND 300 x 75 mm BARGE BOARD
 ON GABLED ENDS

100 x 150 mm GUTTERS ON ALL SIDES

9 mm CEILING BOARDS ON 38 x 38 mm
 BRANDING STRIPS @ 300 mm c/c

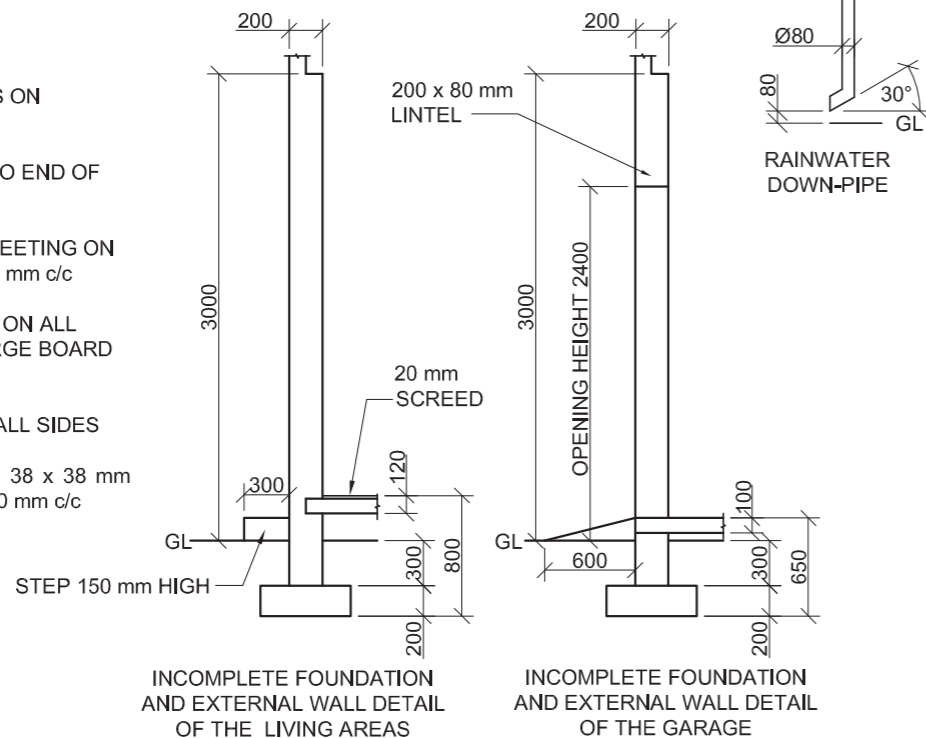

FIXTURES			



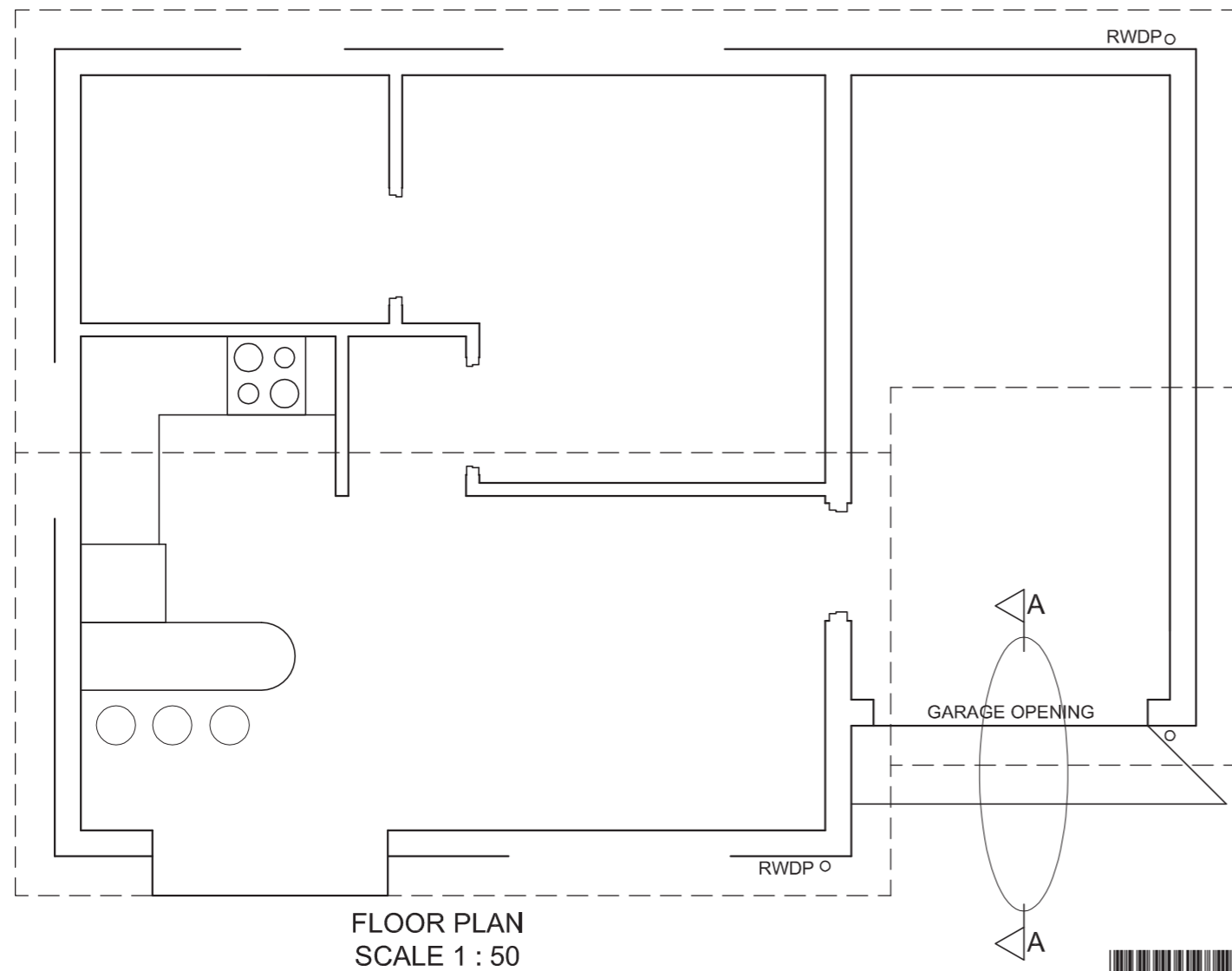

SECTION A-A
SCALE 1 : 20



1. MARK ALLOCATION FOR SECTION OF ROOF		FOR OFFICIAL USE ONLY	
A (1)		INCORRECT SCALE	
B (1)		INCORRECT POSITIONING OF VIEWS	
C (1)		NON-ALIGNMENT OF VIEWS	
D (2)			
E (1)			
F (1)			
G (1)			
H (1)			
I (2)			
TOTAL		TOTAL	

ASSESSMENT CRITERIA				
FLOOR PLAN				
1	DOORS + WINDOWS	14		
2	ELECTRICAL	11		
3	FIXTURES	8		
4	HATCHING	4		
5	LABELS	5		
SUBTOTAL		42		
SOUTH ELEVATION				
1	ROOF	5 1/2		
2	WALLS + RWDP + FFL	7		
3	DOOR + WINDOW	10		
4	LABELS	1		
SUBTOTAL		23 1/2		
DETAILED SECTION				
1	ROOF	11		
2	FOUNDATION + WALLS + SLAB	7		
3	GUTTER + RWDP	4		
4	HATCHING	5		
5	LABELS	1/2		
SUBTOTAL		27 1/2		
TOTAL		93		
PENALTIES (-)				
GRAND TOTAL				
EXAMINATION NUMBER				
				6

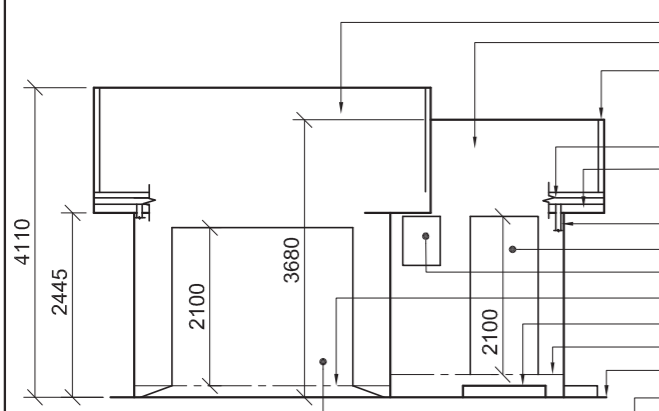

INCOMPLETE SOUTH-EAST ELEVATION

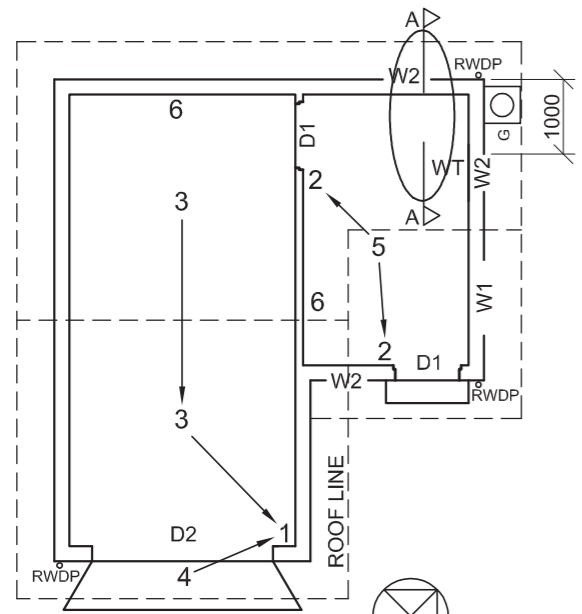

INCOMPLETE FLOOR PLAN

- ROOF 1
- ROOF 2
- 300 x 100 mm BARGE BOARD ON ALL GABLED ENDS
- 150 x 100 mm GUTTER
- 200 x 20 mm FASCIA BOARD
- Ø70 mm RWDP
- DOOR OPENING
- WINDOW OPENING
- FINISHED FLOOR LEVEL (GARAGE)
- 150 mm HIGH STEP
- FINISHED FLOOR LEVEL (WASHROOM)
- GROUND LEVEL
- GARAGE DOOR OPENING

- FEATURES**
- D1 DOOR
 - D2 GARAGE DOOR
 - W1 WINDOW
 - W2 WINDOW
- FIXTURE**
- WT WASHTUB
- ELECTRICAL FITTINGS**
- ONE-WAY SWITCH - DOUBLE-POLE
 - TWO-WAY SWITCH
 - FLUORESCENT LIGHT 2 x 40 W
 - WALL-MOUNTED LIGHT
 - CEILING LIGHT
 - SWITCHED SOCKET OUTLET

NOTE:
THE ARROW SHOWS THE LIGHT CONNECTION TO THE SWITCH.

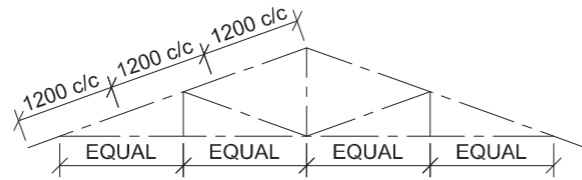

SCHEMATIC DIAGRAM OF A TRUSS FOR ROOF '1'

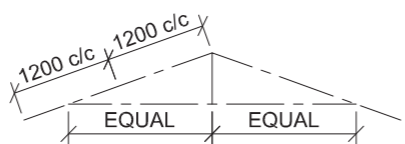

SCHEMATIC DIAGRAM OF A TRUSS FOR ROOF '2'

- ROOF NOTES:**
ROOF PITCH 20°
- 200 x 20 mm FASCIA BOARD ON ALL SIDES AND 300 x 20 mm BARGE BOARD ON THE GABLED ENDS
 - ROOF COVER 15 mm FIBRE CEMENT SHEETING ON 75 x 50 mm PURLINS SPACED ACCORDING TO SCHEMATIC DIAGRAMS
 - 114 x 38 mm ROOF TRUSS ON 114 x 38 mm WALL PLATES
 - 9 mm CEILING BOARD ON 38 x 38 mm BRANDING STRIPS @ 400 mm c/c
 - 100 x 150 mm GUTTER ON ALL SIDES

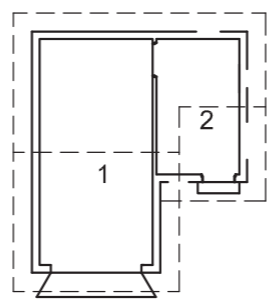

ROOM DESIGNATIONS

- FLOOR FINISHES**
- 1 GARAGE: GRANO TILE
 - 2 WASHROOM: TILE

ELECTRICAL SYMBOLS	

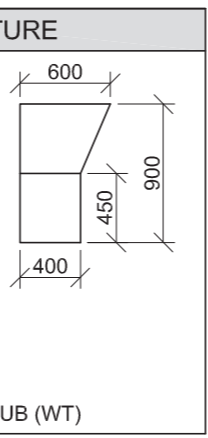
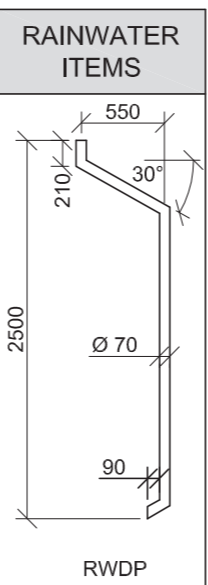

DOOR AND WINDOW SCHEDULE	
	TO FIT
	TO FIT
	1000
	500
	2500

NOTE:
150 x 20 mm FIBRE CEMENT SILL UNDER ALL WINDOWS

ROOF COMPONENTS	
	ROOF CAP
	WALL PLATE
	75 x 50 mm PURLIN
	150 x 100 mm GUTTER
	300 x 100 mm FIBRE CEMENT BARGE BOARD
	200 x 20 mm FASCIA BOARD

QUESTION 4: CIVIL DRAWING

- Given:**
- The incomplete south-east elevation of a **new garage and washroom** showing the walls, the garage door opening, the door and window openings, the roof and notes
 - The incomplete floor plan showing the walls, position of the doors, windows, fixture and the electrical layout
 - The incomplete foundation and external wall detail of the garage and of the washroom
 - Room designations and floor finishes
 - Schematic diagrams of the TWO types of roof trusses and roof notes
 - A table of electrical symbols
 - A table of rainwater items
 - A table of the fixture
 - A door and window schedule
 - A table of roof components
 - The incomplete floor plan of the **new garage and washroom**, drawn to scale 1 : 50, on page 6

- Instructions:**
Answer this question on page 6.
- 4.1 Using the given incomplete floor plan, draw, in first-angle orthographic projection and to scale 1 : 50, the following views of the **new garage and washroom**:
- 4.1.1 **THE COMPLETE FLOOR PLAN**
Add the following features to the drawing:
- ALL doors and windows
 - The fixture as indicated by the abbreviation
 - ALL electrical fittings as indicated by numbers
 - ALL hatching detail
- 4.1.2 **THE COMPLETE SOUTH-EAST ELEVATION**
Show the following features on the drawing:
- The outside walls, door and window detail
 - The roof detail, including the fascia boards, barge boards, gutters, rainwater down-pipe and gully
 - The finished floor level

- 4.2 In the space provided, draw, to **scale 1 : 20**, a **DETAILED SECTION** on cutting plane A-A of the area in the ellipse shown on the incomplete floor plan.
Show the following features on the drawing:
- The complete foundation and external wall detail
 - The window detail, with a DOUBLE lintel
 - The roof detail, including the fascia board and gutter
 - ALL features and fixtures to the right of the section
 - ALL hatching detail. ONLY the substructure hatching may be drawn in neat freehand.

- Label the following:**
- The south-east elevation
 - The room designations and floor finishes
 - Using the correct abbreviations, label the following features in the correct view: ground level, finished floor level and damp-proof course.

NOTE:

- Planning is essential.
- ALL drawings must comply with the **guidelines** and **graphical symbols** as contained in the **SANS 10143**.



STAPLE

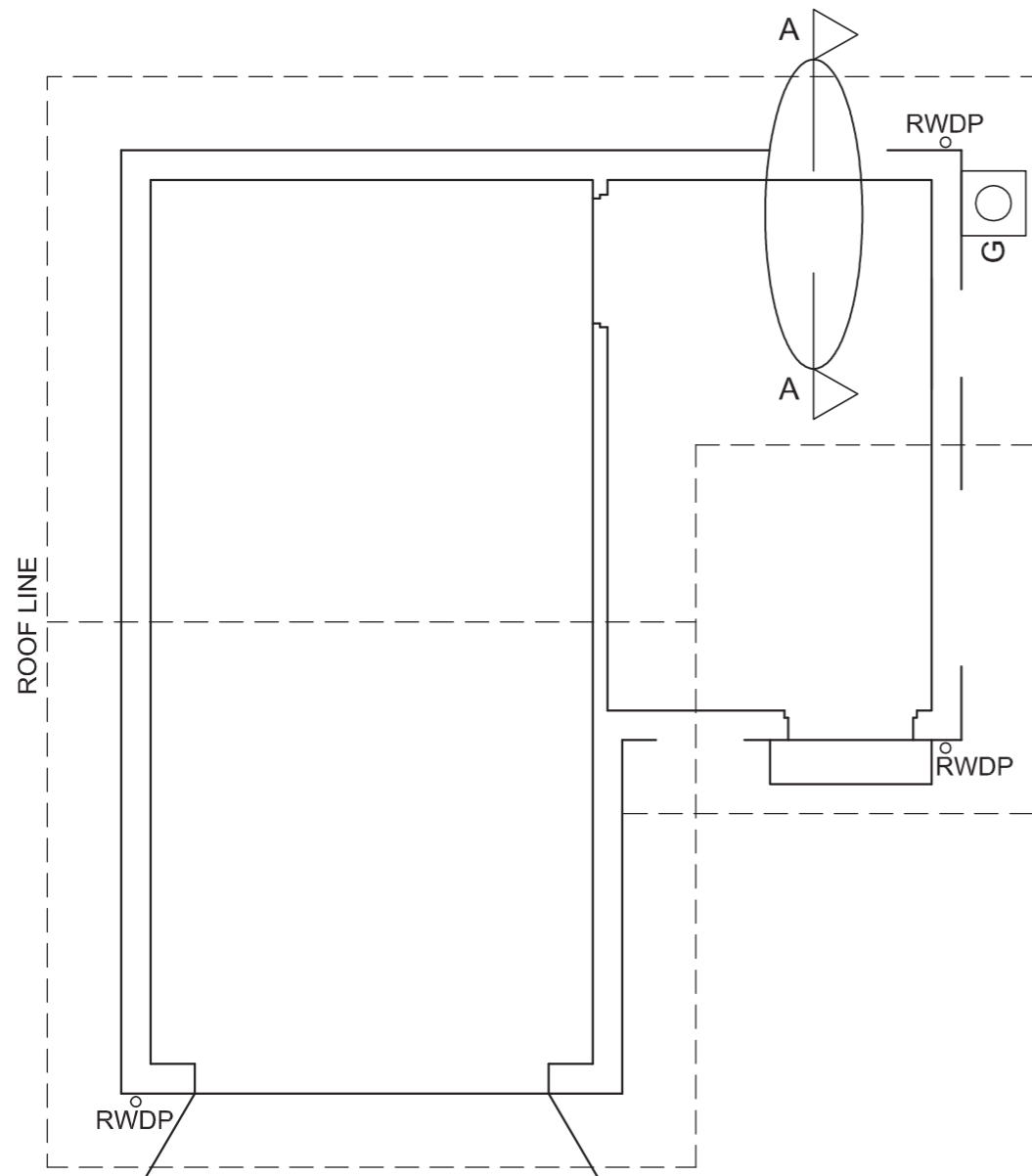

FLOOR PLAN
SCALE 1 : 50

DETAILED SECTION ON A-A
SCALE 1 : 20

FOR OFFICIAL USE ONLY		
INCORRECT SCALE(S)		
NON-ALIGNMENT OF VIEWS		
VIEW(S) ROTATED		
SECTION VIEWED INCORRECTLY		
INCORRECT LETTERING		
TOTAL PENALTIES (-)		

MARK ALLOCATION FOR SECTION OF ROOF (4.2 No 1)												
A	B	C	D	E	F	G	H	I	J	K	L	

ASSESSMENT CRITERIA					
FLOOR PLAN					
		POSSIBLE	OBTAINED	SIGN	MODERATE
1	DOORS + WINDOWS	12			
2	ELECTRICAL	8			
3	FIXTURE	2			
4	HATCHING	4			
5	LABELS	2			
SUBTOTAL		28			
SOUTH-EAST ELEVATION					
1	ROOF + RWDP	9			
2	WALLS + FFL + GULLEY + STEP + RAMP	6½			
3	DOOR + WINDOW	7½			
4	LABELS	2			
SUBTOTAL		25			
DETAILED SECTION					
1	ROOF DETAIL + RWDP	16			
2	FOUNDATION + WALL + SLAB + LINE BREAK	9			
3	WINDOW + WT	8			
4	HATCHING	4			
5	LABELS	1			
SUBTOTAL		38			
TOTAL		91			
TOTAL PENALTIES (-)					
GRAND TOTAL					
EXAMINATION NUMBER					
EXAMINATION NUMBER					
				6	



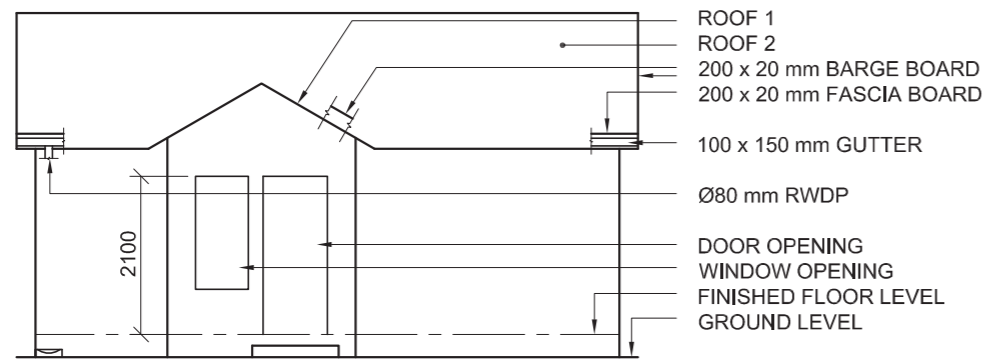

INCOMPLETE NORTH ELEVATION

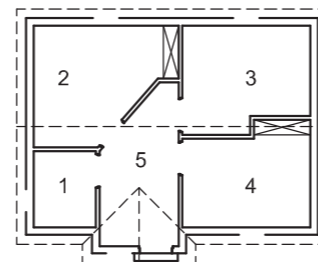

ROOM DESIGNATIONS

FLOOR FINISHES

- 1 TOILET: TILE
- 2 ROOM 1: CARPET
- 3 ROOM 2: CARPET
- 4 ROOM 3: CARPET
- 5 RECEPTION: TILE

FEATURES

- D DOOR
- W1 WINDOW
- W2 WINDOW

FIXTURES

- WC TOILET
- WB WASH BASIN

ELECTRICAL FITTINGS

- 1. ONE-WAY SWITCH - SINGLE-POLE
- 2. ONE-WAY SWITCH - DOUBLE-POLE
- 3. FLUORESCENT LIGHT 2 x 40 W
- 4. CEILING LIGHT
- 5. SWITCHED SOCKET OUTLET

NOTE:

THE ARROW SHOWS THE LIGHT CONNECTION TO THE SWITCH.

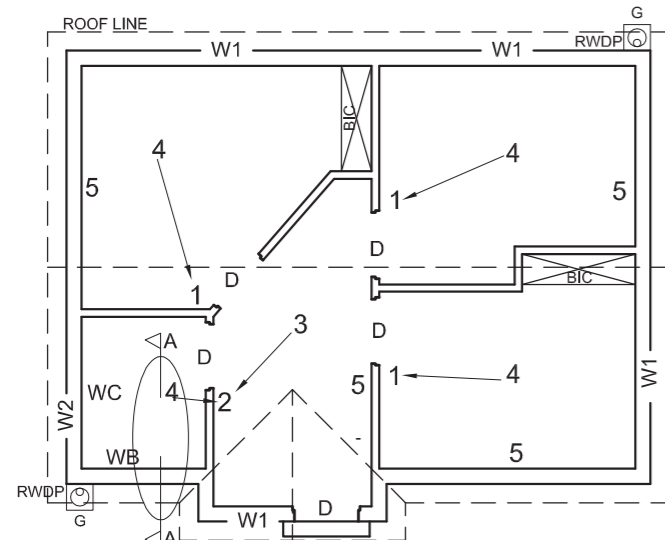

INCOMPLETE FLOOR PLAN

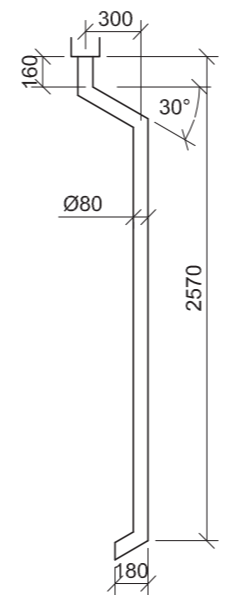

RAINWATER DOWN-PIPE DETAIL

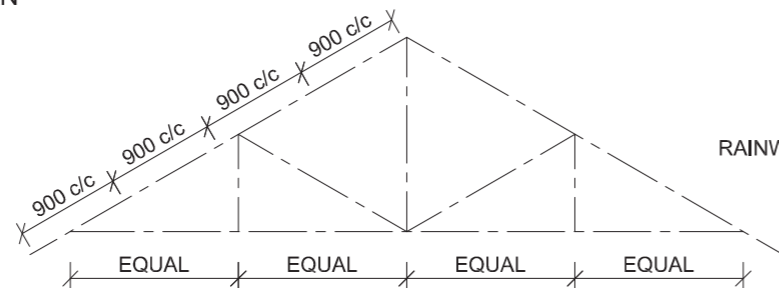

SCHEMATIC DIAGRAM OF A ROOF TRUSS FOR ROOF '2'

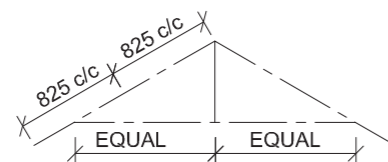

SCHEMATIC DIAGRAM OF A ROOF TRUSS FOR ROOF '1'

ROOF NOTES:
ROOF PITCH 30°

200 x 20 mm FASCIA BOARD ON ALL SIDES AND 200 x 20 mm BARGE BOARD ON THE GABLED ENDS

ROOF COVER 15 mm FIBRE CEMENT SHEETING ON 75 x 50 mm PURLINS SPACED ACCORDING TO SCHEMATIC DIAGRAMS

114 x 38 mm ROOF TRUSSES ON 114 x 38 mm WALL PLATES

9 mm CEILING BOARD ON 38 x 38 mm BRANDERING STRIPS @ 600 mm c/c

100 x 150 mm GUTTER ON ALL SIDES

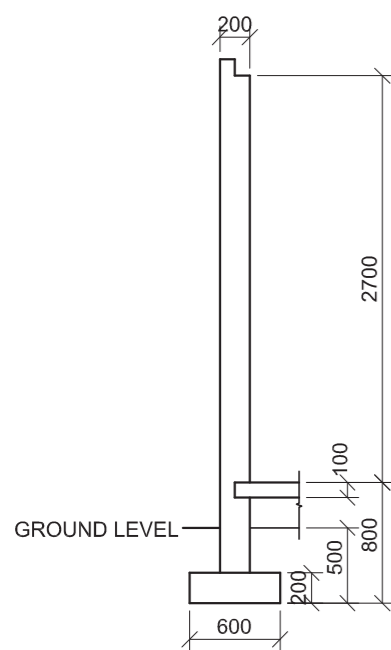

INCOMPLETE FOUNDATION AND EXTERNAL WALL DETAIL

WINDOW AND DOOR SCHEDULE	
<p>WINDOW (W1)</p>	<p>DOOR FRAME AND DOOR (D)</p>
<p>WINDOW (W2)</p>	<p>GULLY (G)</p>
<p>WINDOW NOTES:</p> <ul style="list-style-type: none"> • A = OPENING SIDE • B = HINGED SIDE • C = FIXED PANEL • 150 x 25 mm FIBRE CEMENT SILL UNDER ALL WINDOWS 	

ROOF COMPONENTS	
	38 x 38 mm BRANDERING
	114 x 38 mm WALL PLATE
	75 x 50 mm PURLINS

ELECTRICAL SYMBOLS	

FIXTURES	
<p>TOILET (WC)</p>	<p>WASH BASIN (WB)</p>

QUESTION 4: CIVIL DRAWING

Given:

- The incomplete north elevation of **new consulting rooms**, showing the walls, the door and window openings, the roof and notes
- The incomplete floor plan showing the walls, positions of the doors, windows, fixtures and electrical layout
- The incomplete foundation and external wall detail
- Room designations and floor finishes
- The rainwater down-pipe detail
- Schematic diagrams of the TWO types of roof trusses and roof notes
- A window and door schedule
- The gully detail
- A table of roof components
- A table of electrical symbols
- A table of fixtures
- The incomplete floor plan of the **new consulting rooms**, drawn to scale 1 : 50, on page 6

Instructions:

Answer this question on page 6.

4.1 Using the given incomplete floor plan, draw, in first-angle orthographic projection and to scale 1 : 50, the following views of the **new consulting rooms**:

4.1.1 THE COMPLETE FLOOR PLAN

Add the following features to the drawing:

- ALL doors and windows
- ALL fixtures as indicated by abbreviations
- ALL electrical fittings as indicated by numbers
- ALL hatching detail

4.1.2 THE COMPLETE NORTH ELEVATION

Show the following features on the drawing:

- The outside walls, door and window detail
- The roof detail, including the fascia boards, barge boards, gutters, rainwater down-pipe and gully
- The finished floor level

4.2 In the space provided, draw, to **scale 1 : 20**, a **DETAILED SECTION** on cutting plane A-A of the area in the ellipse shown on the incomplete floor plan.

Show the following features on the drawing:

- The complete foundation and external wall detail
- The roof detail, including the fascia board and gutter
- ALL features and fixtures to the left of the section
- ALL hatching detail. ONLY the substructure hatching may be drawn in neat freehand.

Label the following:

- The north elevation
- The room designations and floor finishes
- Using the correct abbreviations, label the following features in the correct view: ground level, damp-proof course and the finished floor level

NOTE:

- Planning is essential.
- ALL drawings must comply with the **guidelines** and **graphical symbols** as contained in the **SANS 10143**. [96]



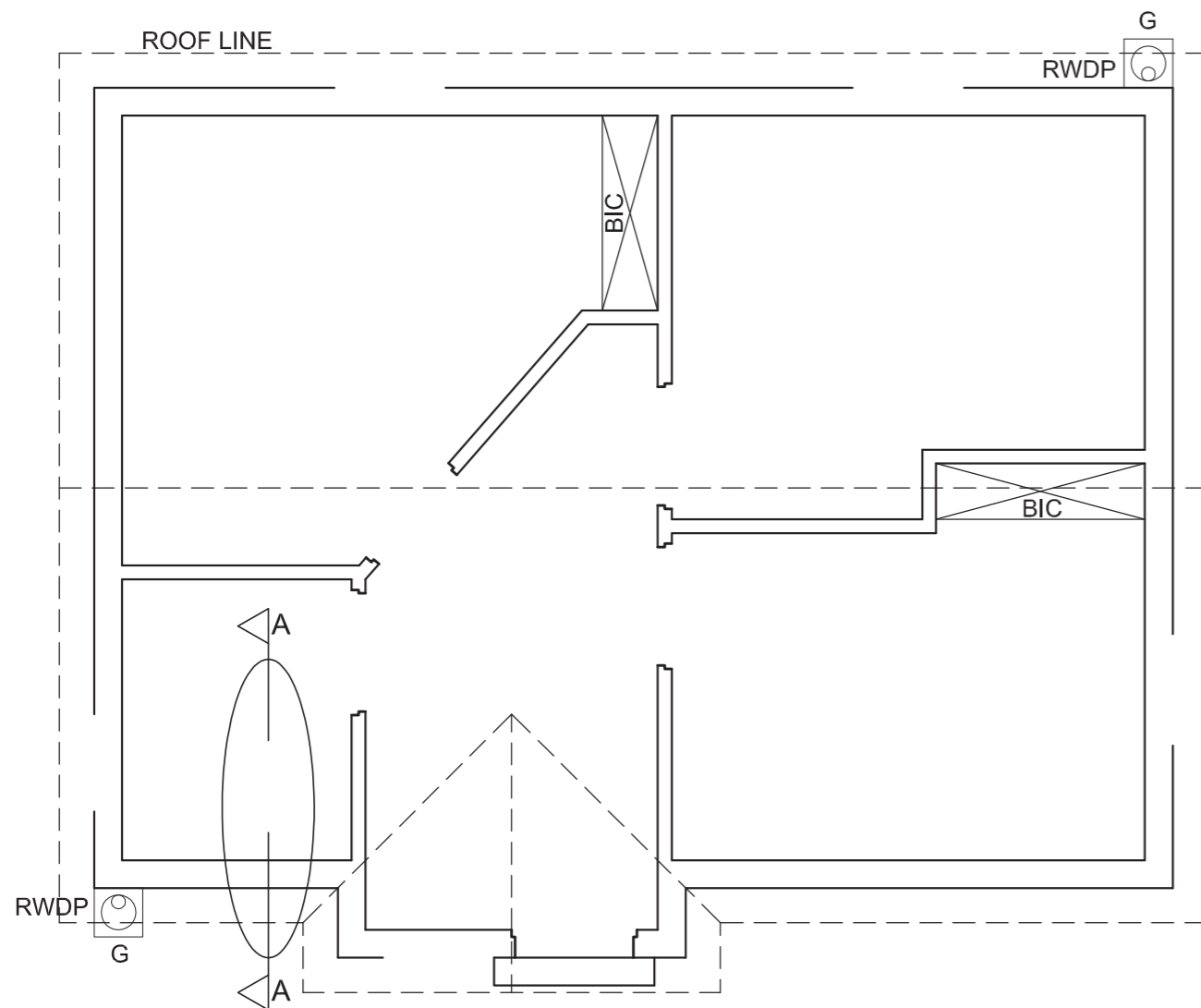

FLOOR PLAN
SCALE 1 : 50

DETAILED SECTION ON A-A
SCALE 1 : 20

FOR OFFICIAL USE ONLY		
INCORRECT SCALE(S)		
NON-ALIGNMENT OF VIEWS		
FEATURES DRAWN IN FREEHAND		
TOTAL PENALTIES (-)		

MARK ALLOCATION FOR SECTION OF ROOF (4.2 No. 1)										
A	B	C	D	E	F	G	H	I	J	

ASSESSMENT CRITERIA					
FLOOR PLAN					
		POSSIBLE	OBTAINED	SIGN	MODERATE
1	DOORS + WINDOWS	15			
2	ELECTRICAL	9			
3	FIXTURES	4			
4	HATCHING	4			
5	LABELS	5			
SUBTOTAL		37			
NORTH ELEVATION					
1	ROOF	8½			
2	WALLS + RWDP + FFL + GULLEY	6½			
3	DOOR + WINDOW	6			
4	LABELS	1½			
SUBTOTAL		22½			
DETAILED SECTION					
1	ROOF DETAIL	11			
2	FOUNDATION + WALL + RWDP + GULLEY + LINE BREAK	11			
3	WINDOW + WC + WB	9½			
4	HATCHING	4			
5	LABELS	1			
SUBTOTAL		36½			
TOTAL		96			
TOTAL PENALTIES (-)					
GRAND TOTAL					
EXAMINATION NUMBER					
EXAMINATION NUMBER					
				6	



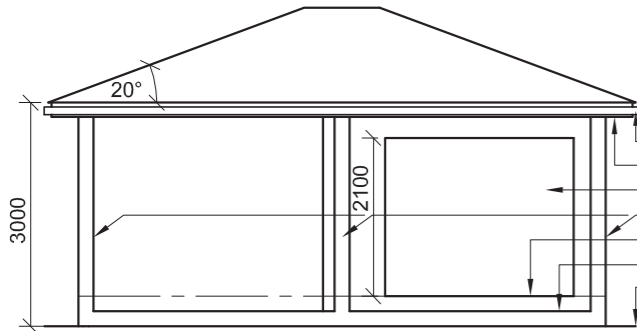

INCOMPLETE SOUTH-WEST ELEVATION

- 100 x 150 GUTTER
- 200 x 20 FASCIA BOARD
- SLIDING DOOR OPENING
- VERANDAH PILLARS
- FLOOR LEVEL
- VERANDAH LEVEL
- GROUND LEVEL

FLOOR FINISHES

- 1 BEDROOM: CARPET
- 2 BATHROOM: TILE
- 3 KITCHEN: TILE
- 4 LOUNGE: TILE
- 5 VERANDAH: GRANO

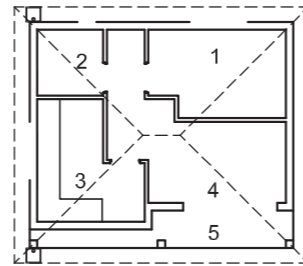

ROOM DESIGNATIONS

FEATURES

- D1 SLIDING DOOR
- D2 INTERNAL DOOR
- W1 WINDOW
- W2 WINDOW

FIXTURES

- WC TOILET
- WB WASH BASIN
- SH SHOWER
- S SINK

ELECTRICAL FITTINGS

- 1. LIGHT SWITCH - SINGLE-POLE
- 2. LIGHT SWITCH - DOUBLE-POLE
- 3. FLUORESCENT LIGHT 2 x 40 W
- 4. CEILING LIGHT
- 5. WALL MOUNTED LIGHT
- 6. SWITCHED SOCKET OUTLET
- 7. DISTRIBUTION BOARD

NOTE:

THE ARROW SHOWS THE LIGHT CONNECTION TO THE SWITCH.

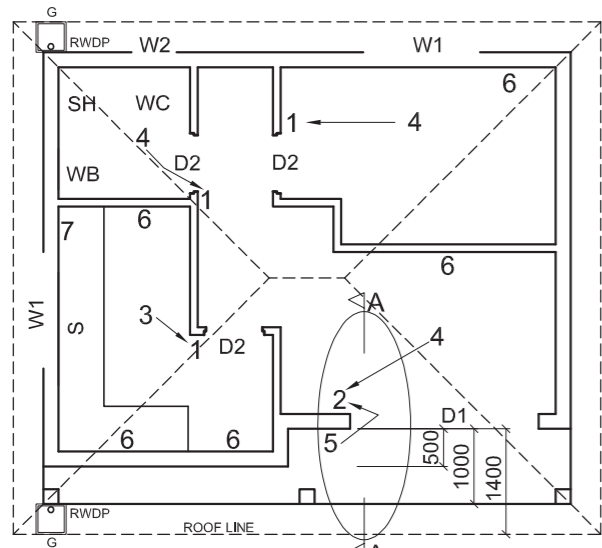

INCOMPLETE FLOOR PLAN

ROOF NOTES:

ROOF PITCH 20° WITH 200 x 20 mm FACIA BOARD ON ALL SIDES

ROOF COVER 15 mm FIBRE CEMENT SHEET ON 75 x 50 mm PURLINS @ 900 mm c/c

115 x 38 mm ROOF TRUSS ON 115 x 38 mm WALL PLATES

9 mm CEILING BOARD ON 38 x 38 mm BRANDING STRIPS @ 600 mm c/c

100 x 150 mm GUTTER ON ALL SIDES

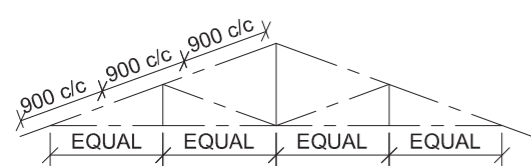

SCHEMATIC DIAGRAM OF A ROOF TRUSS

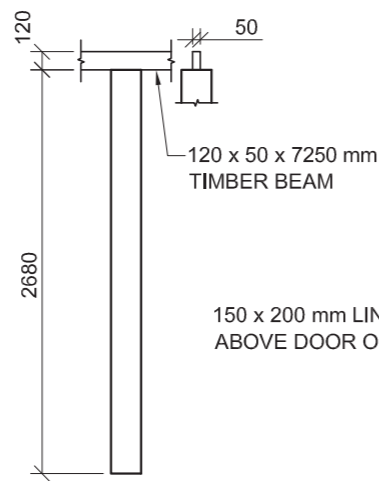

200 x 200 mm VERANDAH PILLAR AND BEAM DETAIL

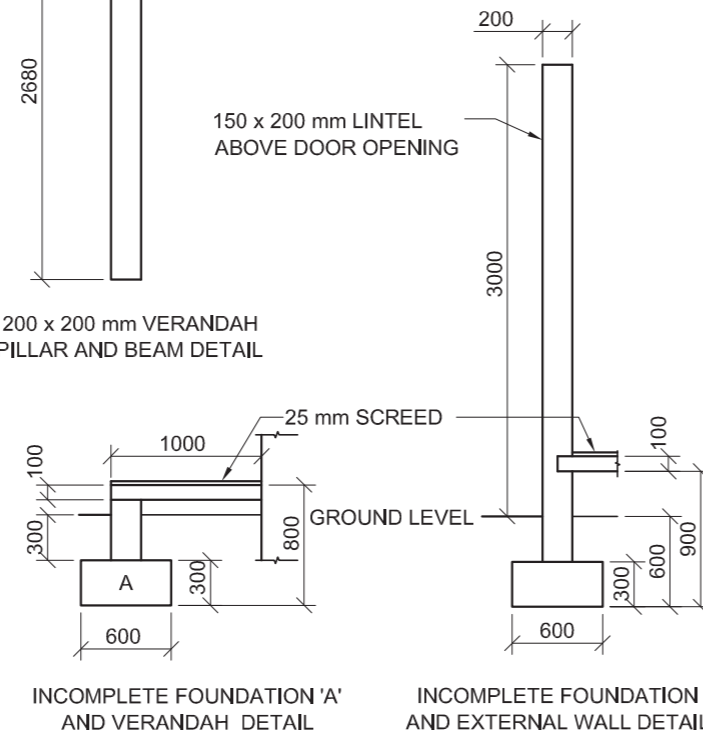

INCOMPLETE FOUNDATION 'A' AND VERANDAH DETAIL

INCOMPLETE FOUNDATION AND EXTERNAL WALL DETAIL

DOOR AND WINDOW SCHEDULE

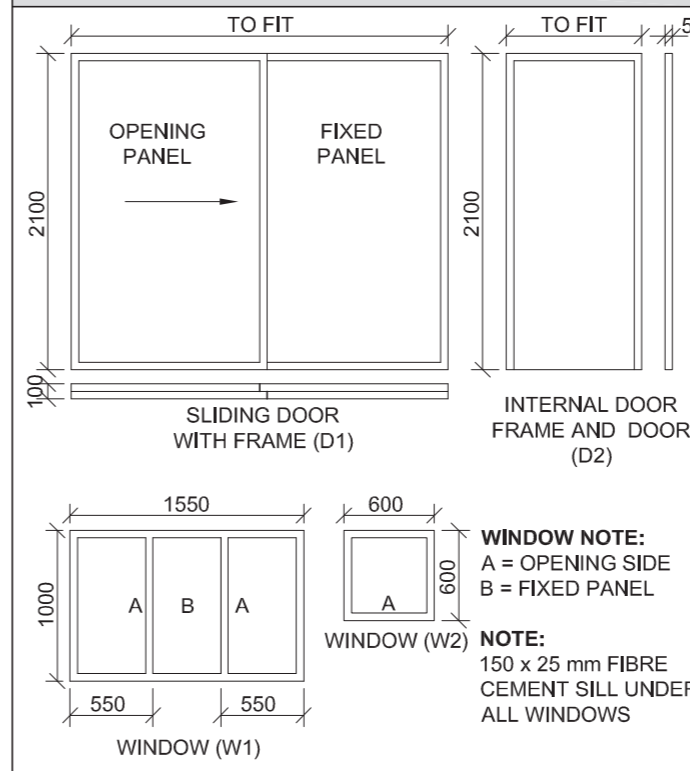

RAINWATER ITEMS

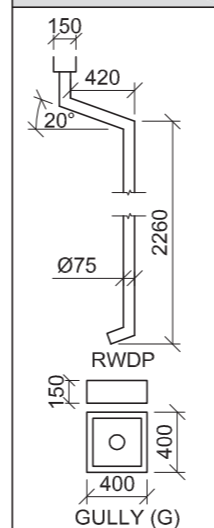

ROOF COMPONENTS

	200 x 20 mm FASCIA BOARD
	120 x 50 x 7250 mm TIMBER BEAM
	75 x 50 mm PURLINS

ELECTRICAL SYMBOLS

FIXTURES

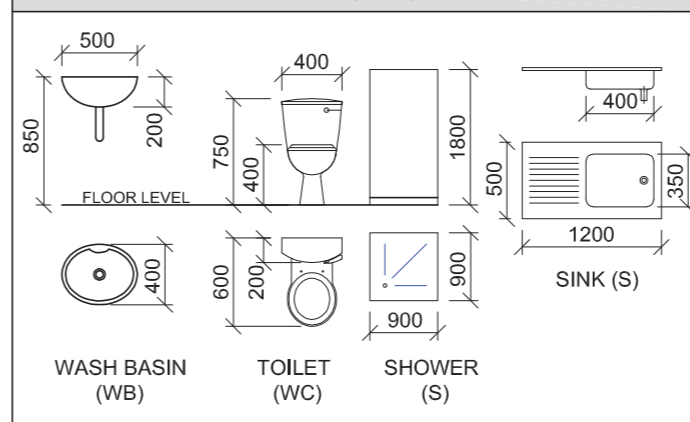

QUESTION 4: CIVIL DRAWING

Given:

- The incomplete south-west elevation of a **new cottage**, showing the walls, the verandah pillars, the sliding door opening, the roof and notes
- The incomplete floor plan showing the walls, position of the verandah pillars, doors, windows, fixtures and electrical layout
- Roof notes with a schematic diagram of a roof truss
- Room designations and floor finish
- Verandah pillar and beam detail
- The incomplete foundation 'A' and verandah detail
- The incomplete foundation and external wall detail
- A door and window schedule
- A table of rainwater items
- A table of roof components
- A table of electrical symbols
- A table of fixtures
- The incomplete foundation 'A' and floor plan of the **new cottage**, drawn to scale 1 : 50, on page 6

Instructions:

Answer this question on page 6.

4.1 Using the given incomplete floor plan, draw, in first-angle orthographic projection and to scale 1 : 50, the following views of the **new cottage**:

4.1.1 THE COMPLETE FLOOR PLAN

Add the following features to the drawing:

- ALL doors and windows
- ALL fixtures as indicated by abbreviations
- ALL electrical fittings as indicated by numbers
- ALL hatching detail

4.1.2 THE SOUTH-WEST ELEVATION

Show the following features on the drawing:

- The outside walls, verandah and sliding door detail
- The roof detail, including the fascia board, gutter, rainwater down pipe and gully
- The finished floor level

4.2 Using the given incomplete foundation 'A', draw, to **scale 1 : 20**, a **DETAILED SECTION** on cutting plane A-A of the area in the ellipse shown on the incomplete floor plan.

Show the following features on the drawing:

- The complete foundation 'A' and verandah detail
- The complete foundation, external wall and sliding door detail
- The roof detail, including the fascia board and gutter
- ALL features of the verandah to the left of cutting plane A-A, including the rainwater down pipe and gully
- ALL hatching detail. ONLY the substructure hatching may be drawn in neat freehand.

Label the following:

- The south-west elevation
- The room designations and floor finishes
- Using the correct abbreviations, label the following features in the correct view: ground level and finished floor level.

NOTE:

ALL drawings must comply with the **guidelines** and **graphical symbols** contained in the *SANS 10143*. [94]



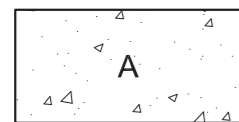
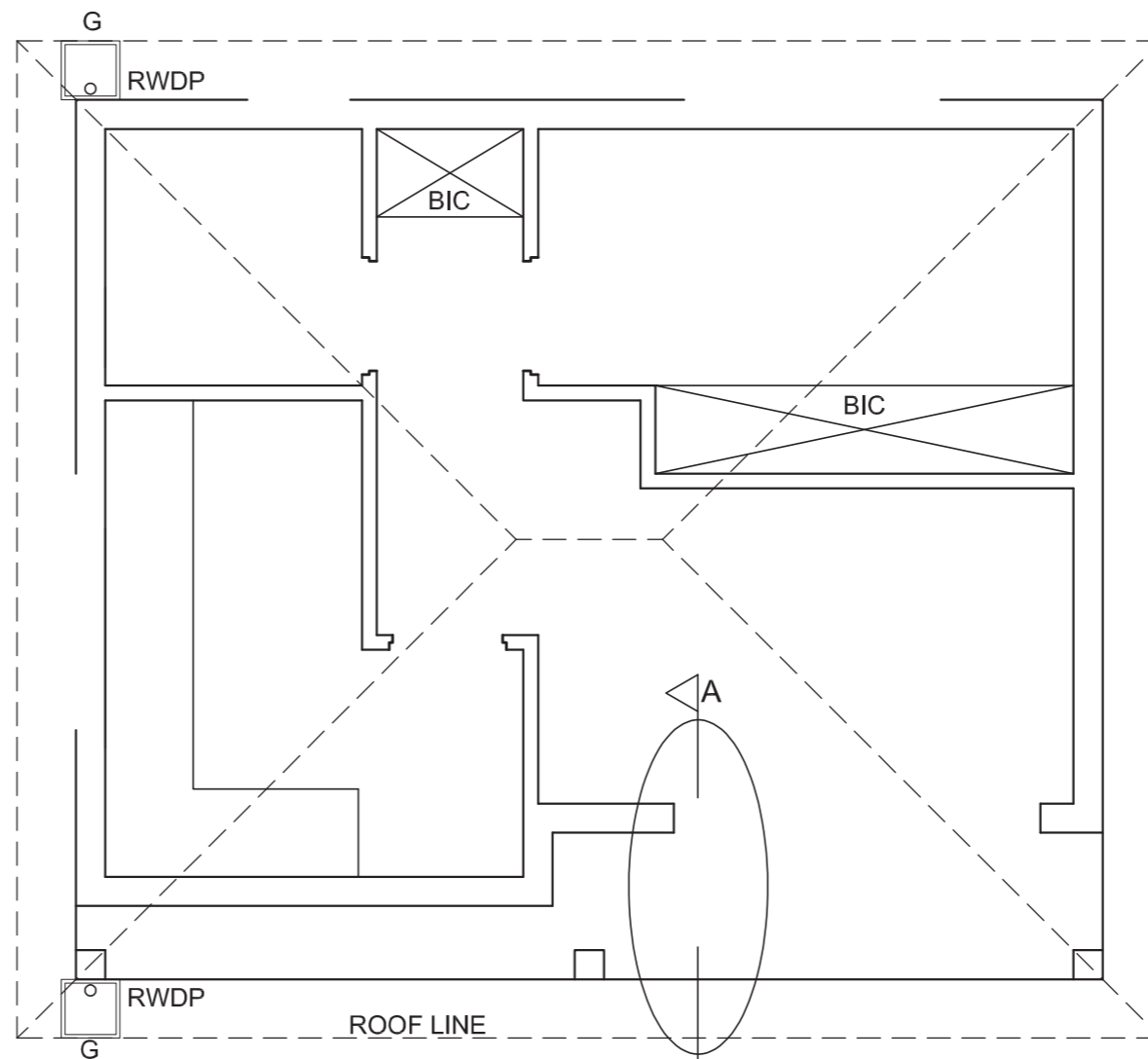

DETAILED SECTION
SCALE 1 : 20

FLOOR PLAN
SCALE 1 : 50

PENALTIES		
INCORRECT OVERALL SCALE		
INCORRECT POSITIONING OF VIEWS		
NON-ALIGNMENT OF VIEWS		
TOTAL PENALTIES (-)		

ASSESSMENT CRITERIA					
FLOOR PLAN					
		POSSIBLE	OBTAINED	SIGN	MODERATE
1	DOORS + WINDOWS	12			
2	ELECTRICAL	10			
3	FIXTURES	4			
4	HATCHING	4			
5	LABELS	5			
SUBTOTAL		35			
SOUTH-WEST ELEVATION					
1	ROOF	6½			
2	WALLS + RWDP + FFL + GULLY	9			
3	DOOR	3			
4	LABELS	1½			
SUBTOTAL		20			
DETAILED SECTION					
1	ROOF DETAIL	12			
2	FOUNDATIONS + WALLS + SLAB	11½			
3	DOOR + GULLY RWDP + GUTTER	9			
4	HATCHING	6½			
SUBTOTAL		39			
TOTAL		94			
TOTAL PENALTIES (-)					
FINAL TOTAL					
EXAMINATION NUMBER					
EXAMINATION NUMBER				6	



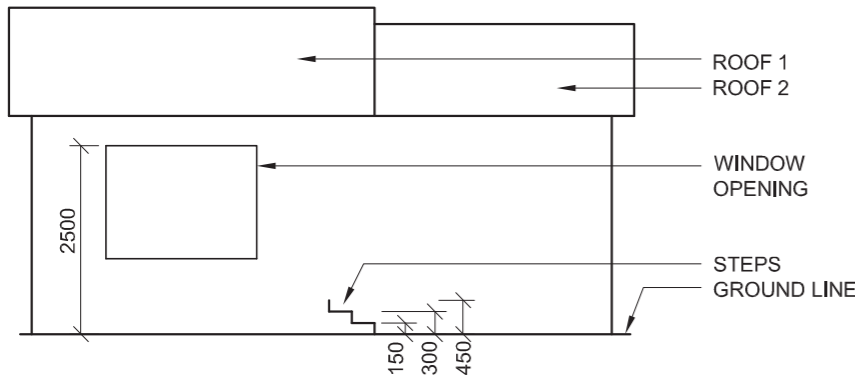

INCOMPLETE NORTH ELEVATION

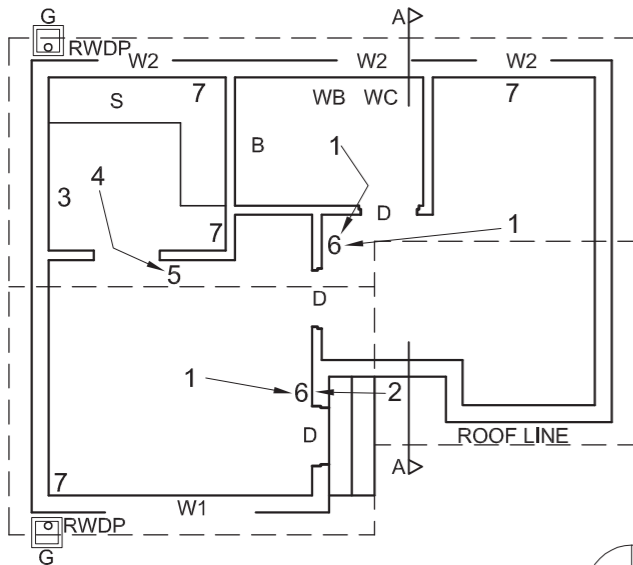

INCOMPLETE FLOOR PLAN

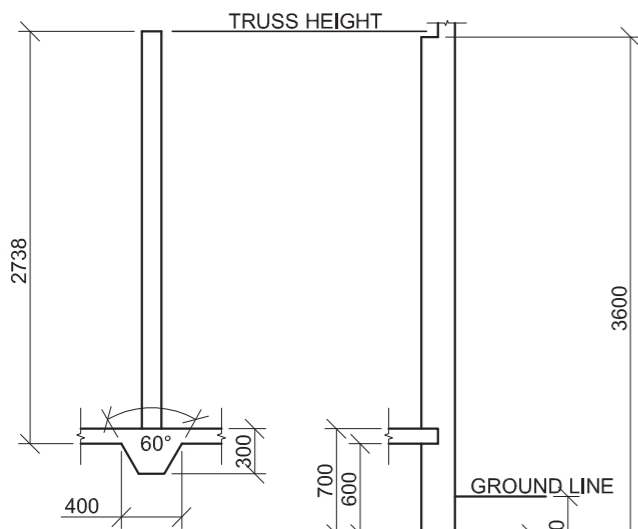

INCOMPLETE FOOTING AND INTERNAL WALL DETAIL

INCOMPLETE FOUNDATION AND EXTERNAL WALL DETAIL

FEATURES
D DOOR
W1 WINDOW
W2 WINDOW

FIXTURES
S SINK
B BATH
BIC BUILT-IN CUPBOARD (600 mm deep)
WC TOILET
WB WASH BASIN

ELECTRICAL FIXTURES
 1. CEILING LIGHT
 2. WALL-MOUNTED LIGHT
 3. DISTRIBUTION BOARD
 4. FLUORESCENT LIGHT 2 X 40 W
 5. LIGHT SWITCH - SINGLE-POLE
 6. LIGHT SWITCH - TWO-POLE
 7. SWITCHED SOCKET OUTLET

NOTE:
THE ARROWS SHOW THE LIGHT CONNECTION TO THE SWITCHES.

ROOF NOTES:
 ROOF PITCH 20°

ROOF COVER 15 mm FIBRE CEMENT SHEET ON 75 x 50 mm PURLINS

115 x 38 mm ROOF TRUSS ON 115 x 38 mm WALL PLATES

9 mm CEILING BOARD ON 38 x 38 mm BRANDING STRIPS

200 x 25 mm FASCIA BOARDS WITH 150 x 100 mm GUTTER ON BOTH ENDS

Ø100 mm RAIN-WATER DOWN PIPE

400 x 400 x 200 mm GULLY

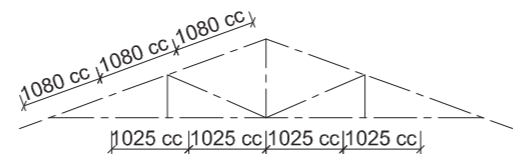

SCHEMATIC DIAGRAM OF A TRUSS FOR ROOF '1'

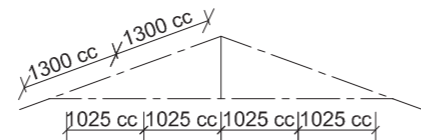

SCHEMATIC DIAGRAM OF A TRUSS FOR ROOF '2'

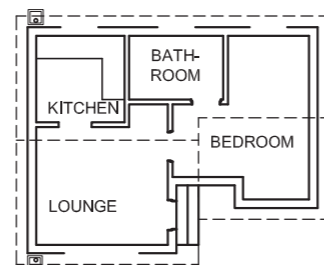

ROOM DESIGNATIONS

FLOOR FINISHES
 KITCHEN: TILES
 LOUNGE: CARPET
 BATHROOM: TILES
 BEDROOM: CARPET

DOOR AND WINDOW SCHEDULE

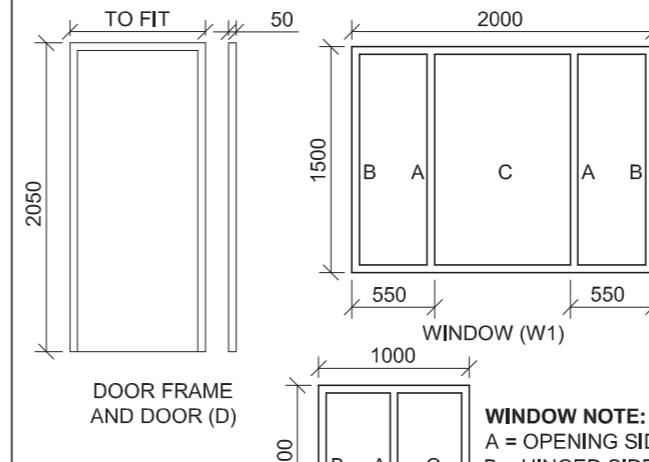

ELECTRICAL SYMBOLS

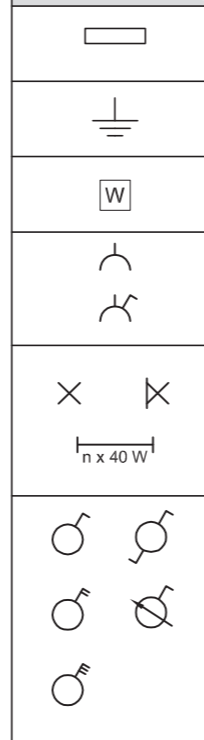

ROOF COMPONENTS

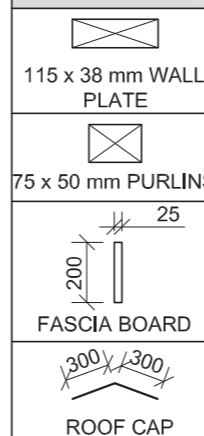

FIXTURES

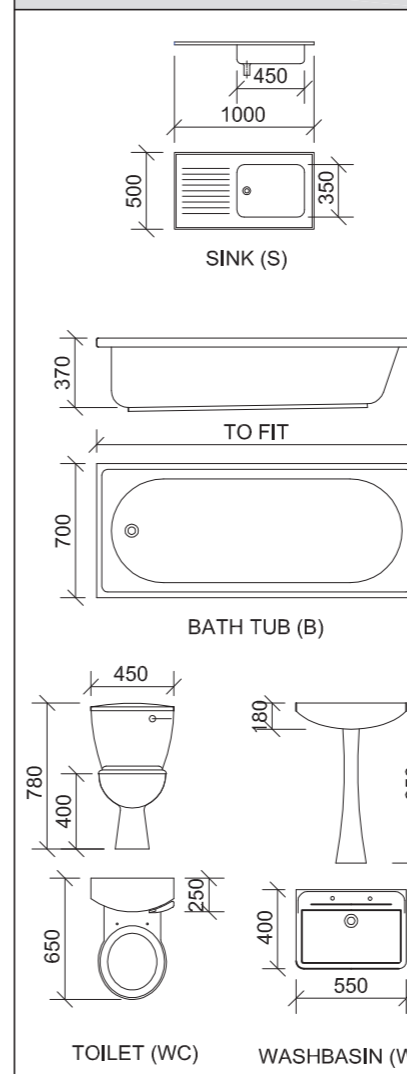

QUESTION 4: CIVIL DRAWING

Given:

- The incomplete north elevation of a new dwelling, showing the walls, the roof and notes
- The incomplete floor plan showing the walls, position of the doors and windows, the fixtures and electrical layout
- The incomplete detail of the footing/foundation of an internal and an external wall
- Roof notes with schematic diagrams of the TWO types of roof trusses
- A diagram showing the room designations and a list of floor finishes
- A door and window schedule
- A table of electrical symbols
- A table of roof components
- A table of fixtures
- The incomplete floor plan of the new dwelling, drawn to scale 1 : 50, on page 6

Instructions:

- Answer this question on page 6.
- Using the given incomplete floor plan, draw, in first-angle orthographic projection and to scale 1 : 50, the following views of the new dwelling:
 - 4.1 The complete floor plan
 - 4.2 The complete north elevation
 - 4.3 A sectional elevation on cutting plane A-A
- ALL drawings must comply with the guidelines and graphical symbols contained in the SANS 10143.

SPECIFICATIONS:

THE FLOOR PLAN

Add the following features to the drawing:

- ALL the doors and windows
- ALL the fixtures as indicated by abbreviations
- ALL the electrical fittings as indicated by numbers
- ALL hatching detail

THE NORTH ELEVATION

Show the following features on the drawing:

- The outside walls, steps and finished floor level
- The roof detail, including the fascia board, gutter, rainwater down pipe and gully
- The window detail

THE SECTIONAL ELEVATION

Show the following features on the drawing:

- The complete footing or foundation, wall, roof and ceiling detail
- The window detail, with a DOUBLE lintel
- ALL features to the west of the cutting plane
- ALL hatching detail

Label the following:

- The room designations and floor finishes
- The sectional elevation and the north elevation
- Using the correct abbreviations, label the following features in the correct view: ground level, finished floor level and damp-proof course.

NOTE:

ONLY the substructure hatching may be drawn in neat freehand.



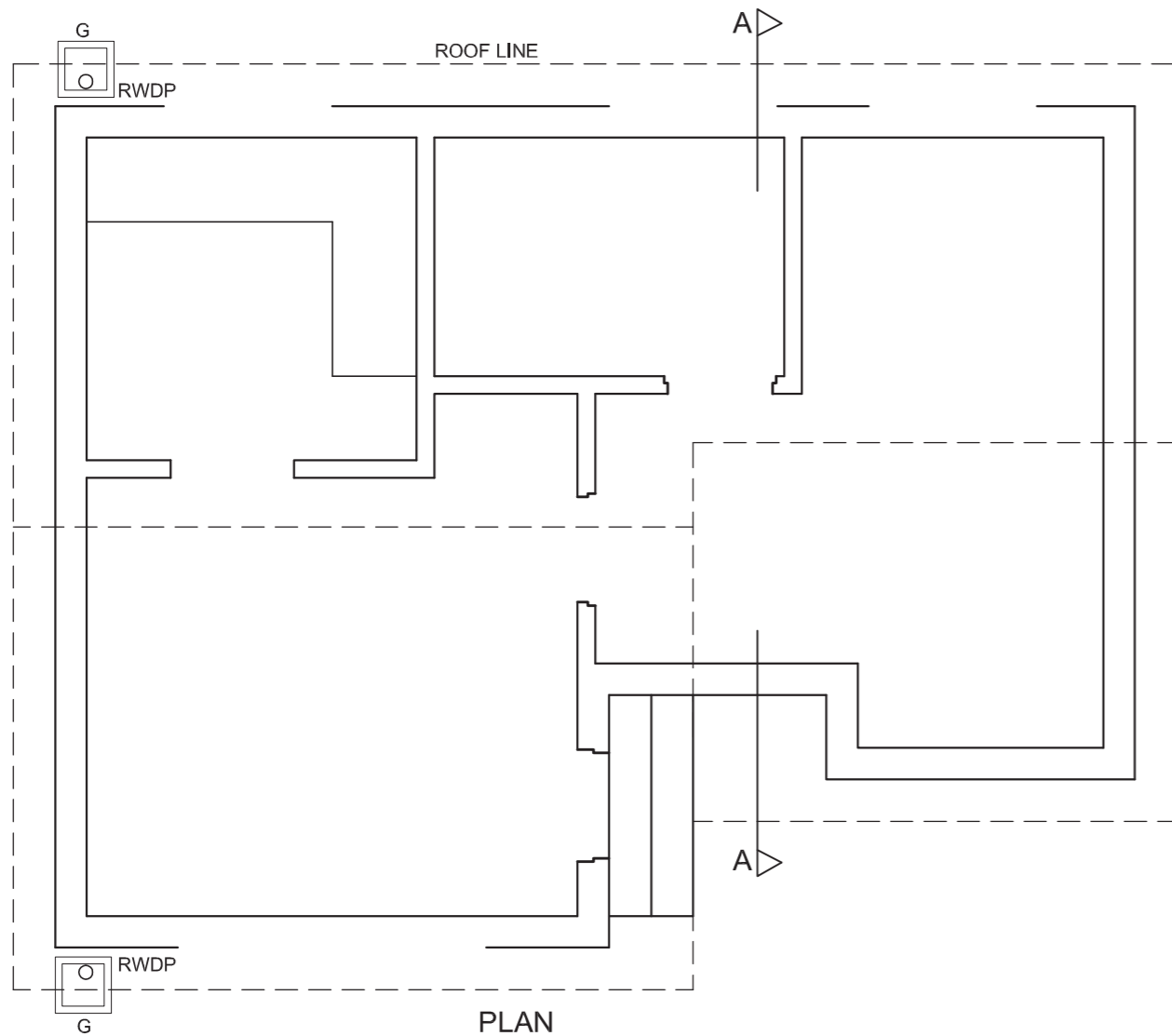

PLAN
SCALE 1 : 50

PENALTIES		
INCORRECT OVERALL SCALE		
INCORRECT POSITIONING OF VIEWS		
NON-ALIGNMENT OF VIEWS		
TOTAL		

ASSESSMENT CRITERIA					
FLOOR PLAN					
		POSSIBLE	OBTAINED	SIGN	MODERATE
1	LABELS	4			
2	ELECTRICAL	9			
3	DOORS + WINDOWS	11			
4	FIXTURES	4			
5	HATCHING	4			
SUBTOTAL		32			
NORTH ELEVATION					
1	WALLS + FFL	5			
2	ROOF + FACIA BOARD + GUTTER + RWDP	7			
3	WINDOW	5½			
4	LABELS	1½			
SUBTOTAL		19			
SECTIONAL ELEVATION					
1	ROOF + FACIA BOARD + GUTTER + RWDP	15			
2	WALLS + FLOOR + FOUNDATION	18			
3	HATCHING	6½			
4	LABELS	2½			
SUBTOTAL		42			
PENALTIES (-)					
TOTAL		93			
EXAMINATION NUMBER					
EXAMINATION NUMBER					
				6	



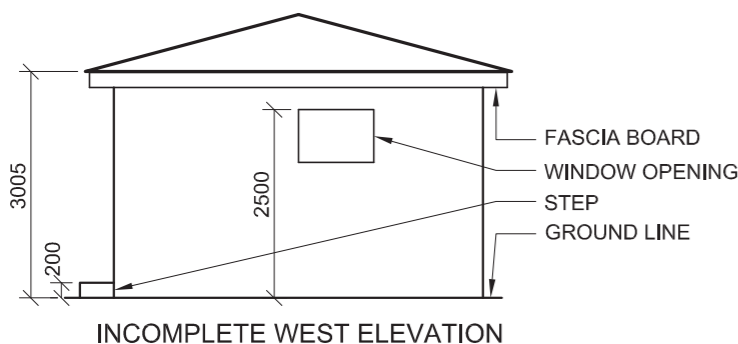

ROOF NOTES:
 ROOF PITCH 15° WITH 200 x 20 mm FASCIA BOARD ON ALL SIDES
 ROOF COVER 15 mm FIBRE CEMENT SHEET ON 75 x 50 mm PURLINS @ 900 mm c/c
 115 x 38 mm ROOF TRUSS ON 115 x 38 mm WALL PLATES
 PLASTER CEILING BOARD ON 38 x 38 mm BRANDING STRIPS @ 700 mm c/c
 100 x 100 mm GUTTER ON ALL SIDES

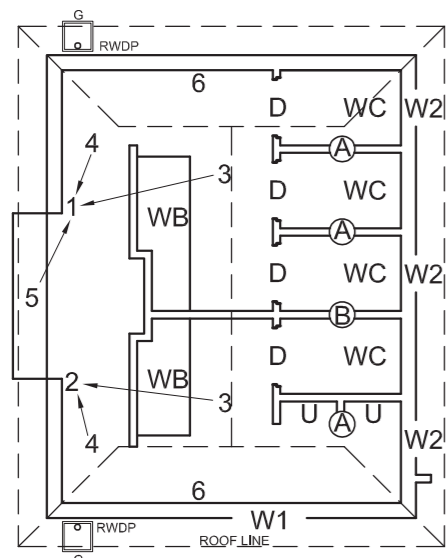
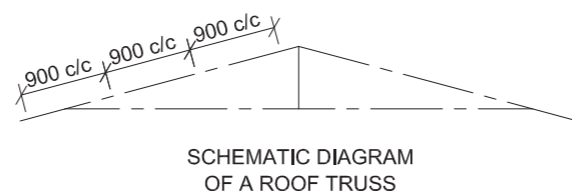

FEATURES
 D DOOR
 W1 WINDOW
 W2 WINDOW

FIXTURES
 WC TOILET
 WB WASH BASIN
 U URINAL

ELECTRICAL FITTINGS:
 1. LIGHT SWITCH THREE-POLE
 2. LIGHT SWITCH DOUBLE-POLE
 3. FLUORESCENT LIGHT 3 X 40 W
 4. CEILING LIGHT
 5. WALL MOUNTED LIGHT
 6. SWITCHED SOCKET OUTLET

NOTE:
 THE ARROW SHOWS THE LIGHT CONNECTION TO THE SWITCH



INCOMPLETE FLOOR PLAN

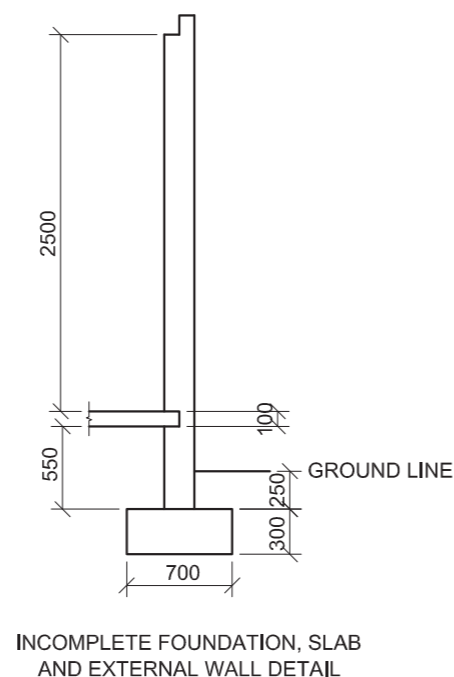
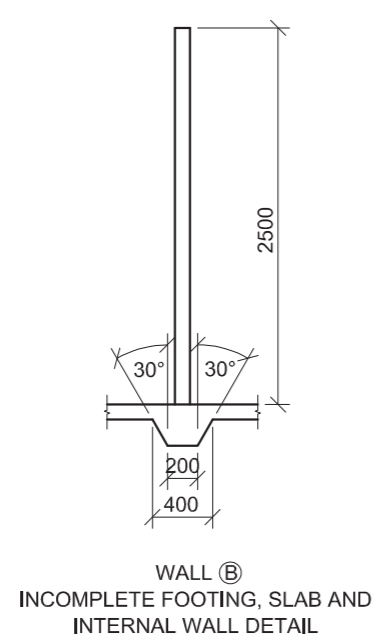
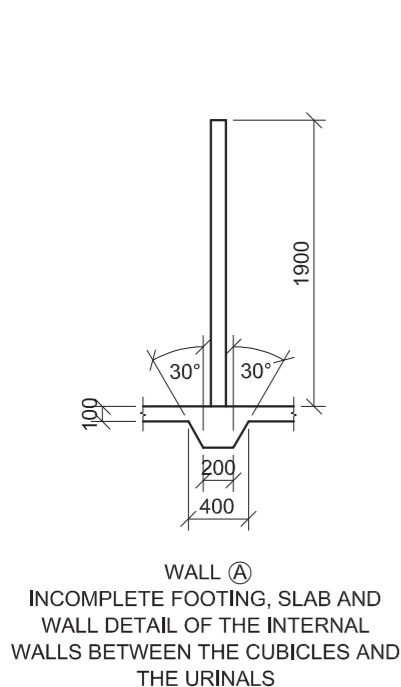

DOOR AND WINDOW SCHEDULE

TO FIT

1900

1700

DOOR FRAME AND DOOR FOR TOILETS

1000

500

900

WINDOW (W1)

WINDOW (W2)

OPEN OUT

HINGED

OPEN IN

NOTES:
 150 x 20 FIBRE CEMENT SILL UNDER ALL WINDOWS

ELECTRICAL SYMBOLS

ROOF COMPONENTS

	ROOF CAP
	115 x 38 WALL PLATE
	75 x 50 PURLINS

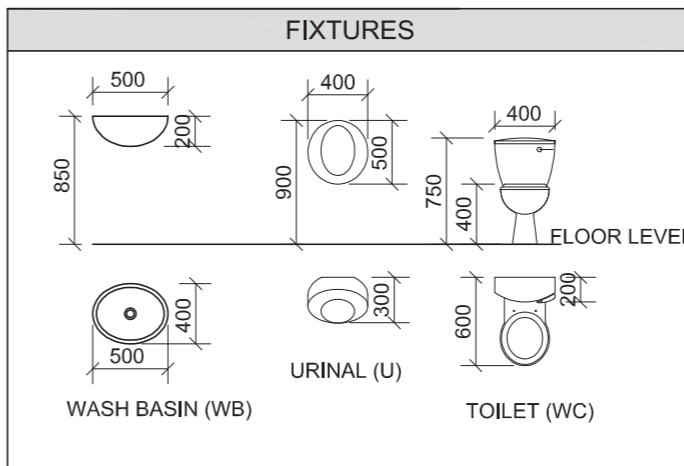
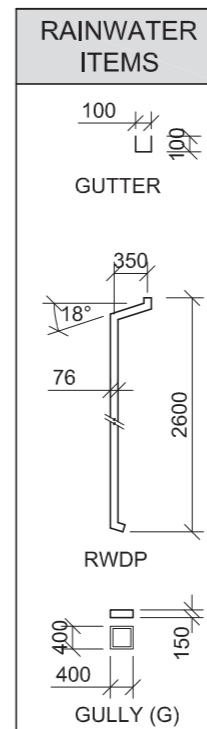
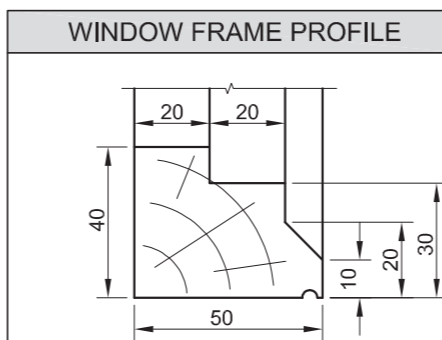

QUESTION 4: CIVIL DRAWING

Given:

- The incomplete west elevation of a new public toilets, showing the walls, the roof and notes
- The incomplete floor plan showing the walls, position of the doors and windows, fixtures and electrical layout
- Roof notes and a schematic diagram of a roof truss
- The incomplete foundation/footing, slab and wall detail of the three walls to be used in the construction of the new public toilets
- A door and window schedule
- A table of roof components
- A table of the wooden window frame profile
- A table of fixtures
- A table of electrical symbols
- A table of rainwater items
- The incomplete plan of the new public toilets, drawn to scale 1 : 50, on page 6

Instructions:

Answer this question on page 6.

4.1 Using the given incomplete floor plan, draw, in first-angle orthographic projection and to scale 1 : 50, the following views of the new public toilets:

4.1.1 THE COMPLETE FLOOR PLAN

Add the following features to the drawing:

- ALL the doors and the window
- ALL fixtures as indicated by abbreviations
- The electrical layout as indicated by numbers
- ALL hatching detail

4.1.2 THE WEST ELEVATION

Show the following features on the drawing:

- The outside walls and window detail
- The roof detail including the fascia board, gutter, rainwater down pipe and gully
- The finished floor level

4.2 Draw, to scale 1 : 20, a DETAILED SECTION on cutting plane A-A of the area in the ellipse shown on the floor plan on page 6.

Show the following features on the drawing:

- The complete foundation and external wall detail
- The complete footing and wall A detail
- The roof detail
- The window detail with a double lintel
- ALL features to the east of the cutting plane A-A
- ALL hatching detail. ONLY the substructure hatching may be drawn in freehand.

Label the following:

- The west elevation
- The room designations and floor finish (tiles)
- Using correct abbreviations, label the following features in the correct view: ground level, finished floor level and damp-proof course.



NOTE:

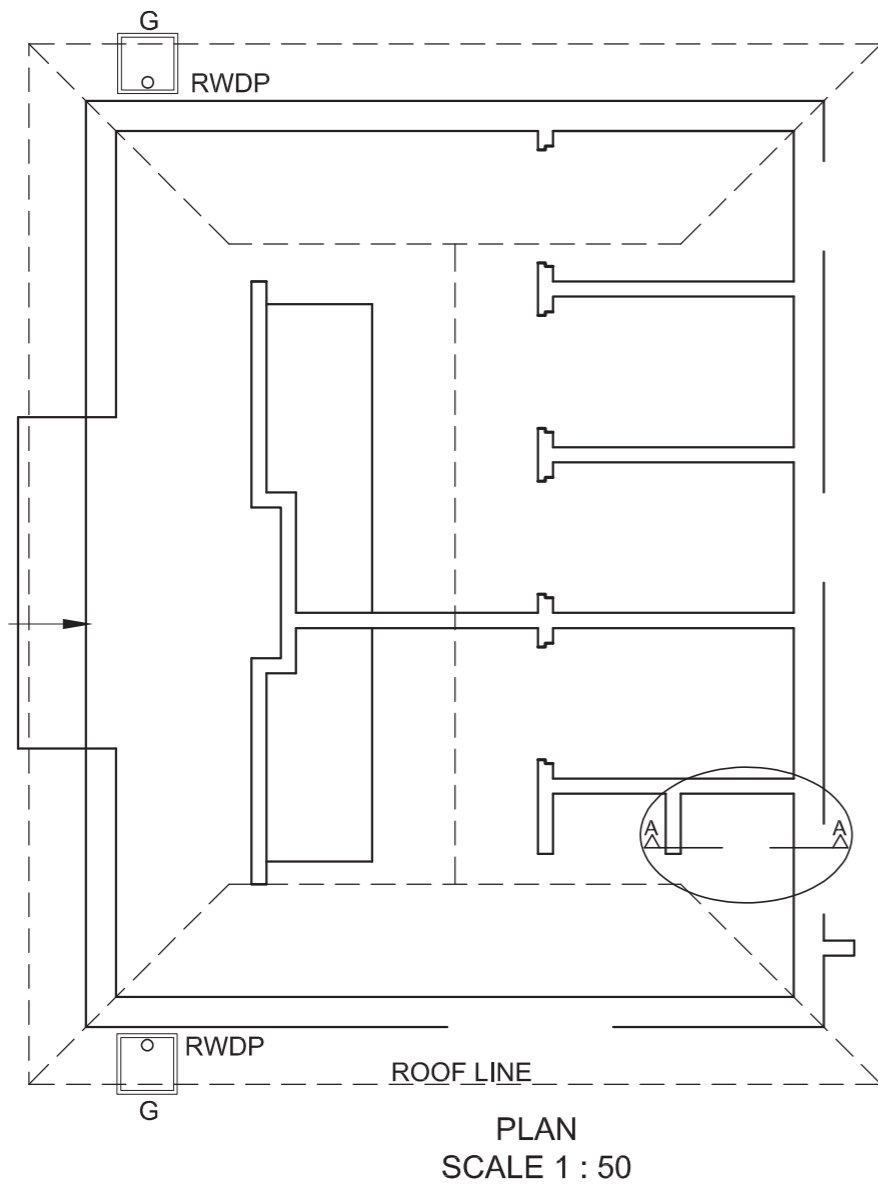









- ALL drawings must comply with the guidelines and graphic symbols contained in the SANS 10143. [92]



DETAILED SECTION
SCALE 1 : 20

ASSESSMENT CRITERIA					
PLAN					
		POSSIBLE	OBTAINED	SIGN	MODERATE
1	DOORS + WINDOWS	12			
2	ELECTRICAL	7			
3	FIXTURES	8			
4	HATCHING	4			
5	LABELS	1			
SUBTOTAL		32			
WEST ELEVATION					
1	ROOF	6			
2	WALLS + RWDP + FFL + G + STEP	5			
3	WINDOW	5			
4	LABELS	2			
SUBTOTAL		18			
DETAILED DRAWING					
1	ROOF	13			
2	WINDOW + SILL	8½			
3	FOUNDATIONS + WALLS + SLAB	10½			
4	HATCHING	5			
5	URINAL + LABELS	5			
SUBTOTAL		42			
PENALTIES (-)					
TOTAL		92			
EXAMINATION NUMBER					
EXAMINATION NUMBER					
6					

ROOF COMPONENTS	
	114 x 38 WALL PLATE
	75 x 50 PURLINS
	ROOF CAP

ELECTRICAL SYMBOLS	
	
	
	
	
	

WINDOW AND DOOR SCHEDULE

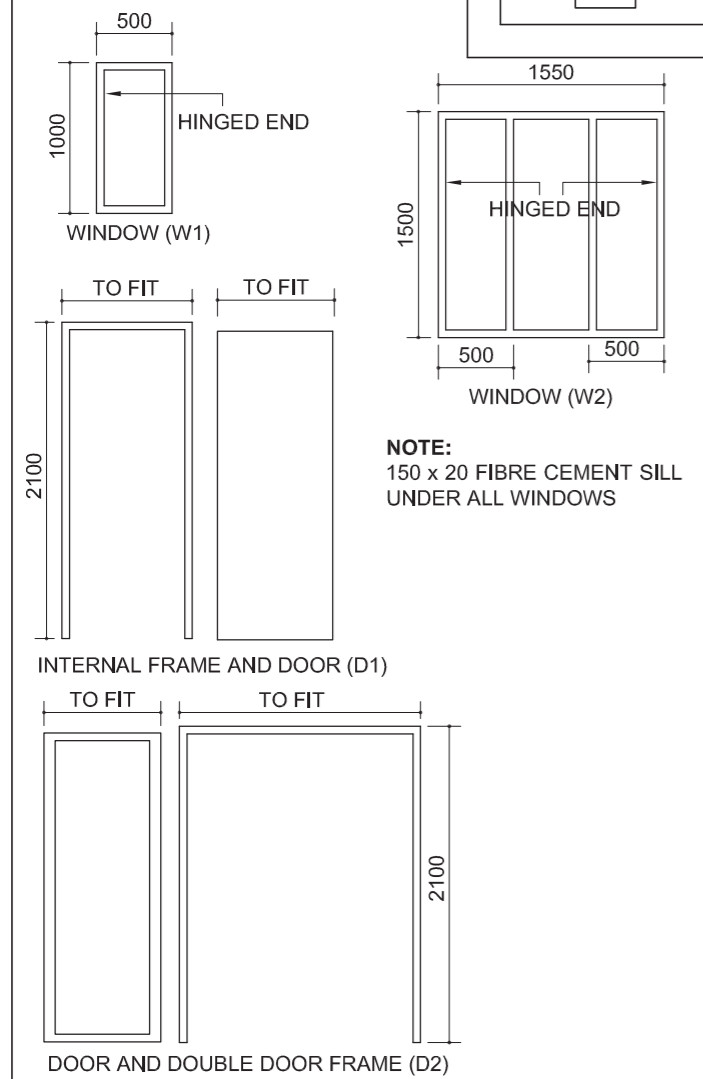

FIXTURES

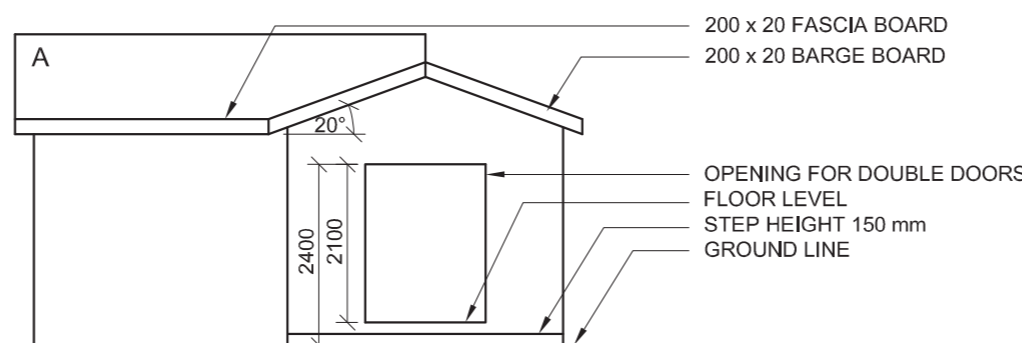
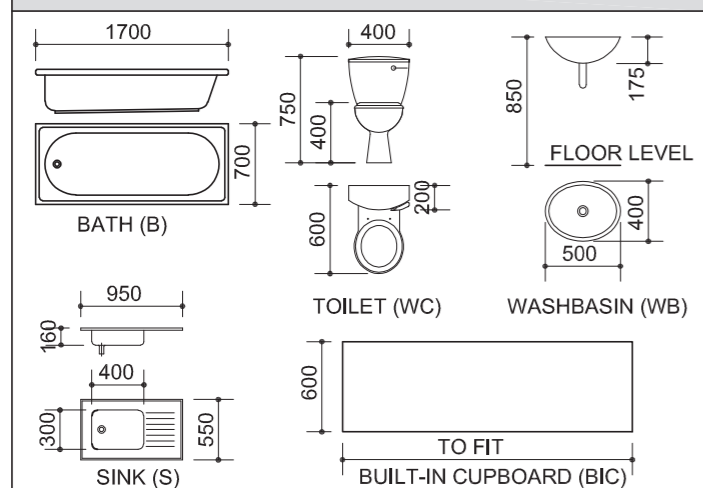

INCOMPLETE NORTH ELEVATION

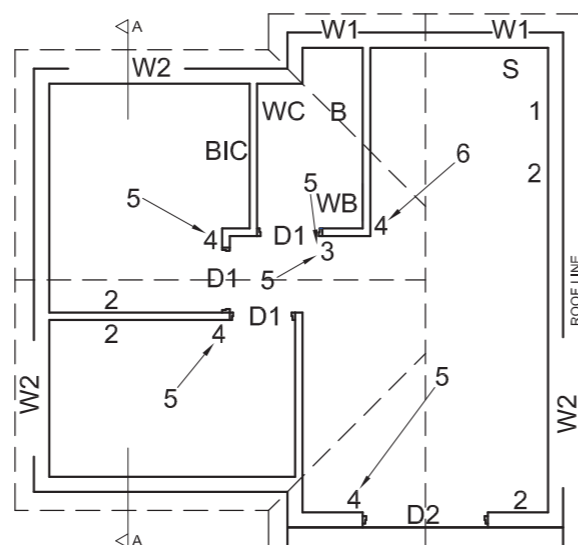

INCOMPLETE FLOOR PLAN



ROOF NOTES:
15 mm FIBRE CEMENT SHEETS ON 75 x 50 mm PURLINS @ 950 mm c/c

114 x 38 mm ROOF TRUSSES ON 114 x 38 mm WALL PLATES

ROOF PITCH 20° WITH 200 x 20 mm FASCIA BOARD AND 200 x 20 mm BARGE BOARDS ON THE GABLES

PLASTER CEILING BOARD ON 38 x 38 mm BRANDERING @ 750 mm c/c

FLOOR FINISH:
BEDROOMS: CARPET
BATHROOM: TILES
KITCHEN: TILES
LIVING ROOM: TILES

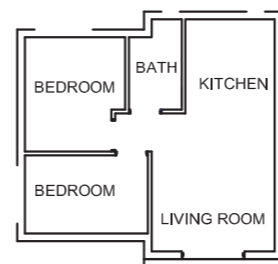

ROOM DESIGNATIONS

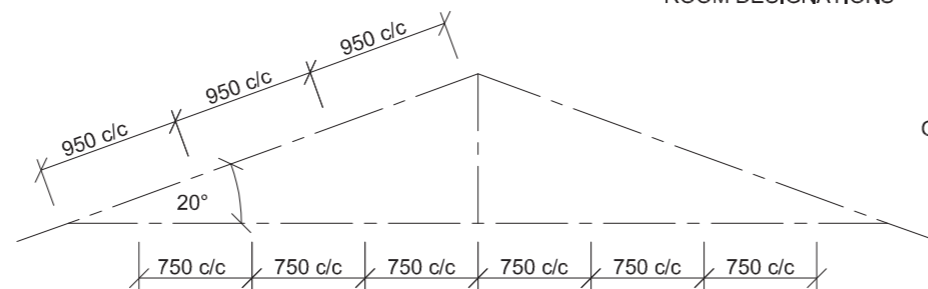

SCHEMATIC DIAGRAM OF A ROOF TRUSS FOR ROOF A

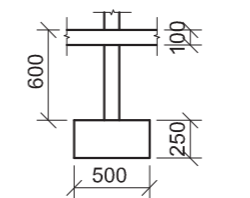

INCOMPLETE FOUNDATION AND INTERNAL WALL DETAIL

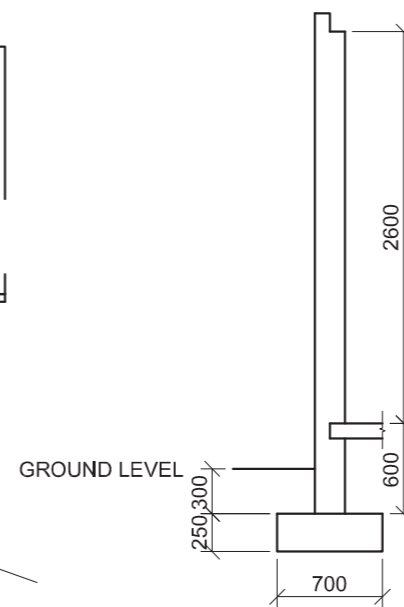

INCOMPLETE FOUNDATION AND EXTERNAL WALL DETAIL

QUESTION 4: CIVIL DRAWING

Given:

- The incomplete north elevation of a new house, showing the walls, the entrance opening, the roof and notes
- The incomplete floor plan, showing the walls, position of the doors, windows, fixtures and the electrical fittings
- Roof notes and a schematic diagram of a roof truss
- The floor finishes and a diagram showing the room designations
- The incomplete foundation, wall detail of an internal and an external wall
- A table of roof components
- A table of electrical symbols
- A window and door schedule
- A table of fixtures
- The incomplete floor plan of the new house, drawn to scale 1 : 50, on page 6

Instructions:

- Answer this question on page 6.
- Using the given incomplete floor plan, draw, in first-angle orthographic projection and to scale 1 : 50, the following views of the new house:
 - 4.1 The complete floor plan
 - 4.2 The north elevation
 - 4.3 A sectional elevation on cutting plane A-A
- ALL drawings must comply with the guidelines and graphical symbols contained in the SANS 10143.

SPECIFICATIONS:

THE FLOOR PLAN

Add the following features to the drawing:

- ALL the doors and windows
- ALL the fixtures as indicated by the abbreviations
- ALL the electrical fittings as indicated by the numbers
- ALL hatching detail

THE NORTH ELEVATION

Show the following features on the drawing:

- The outside walls and the finished floor level
- The double doors and step
- The roof detail, including the barge boards and fascia board

THE SECTIONAL ELEVATION

Show the following features on the drawing:

- The complete foundation, wall, slab, roof and ceiling detail
- The window detail, with a double lintel
- The detail of the window on the east-facing wall
- ALL hatching detail

Label the following:

- The room designations with floor finishes
- The north elevation and the sectional elevation
- Using the correct abbreviations, label the following features in the correct view: natural ground level, finished floor level and damp-proof course

NOTE:

ALL substructure hatching may be drawn in freehand. [96]



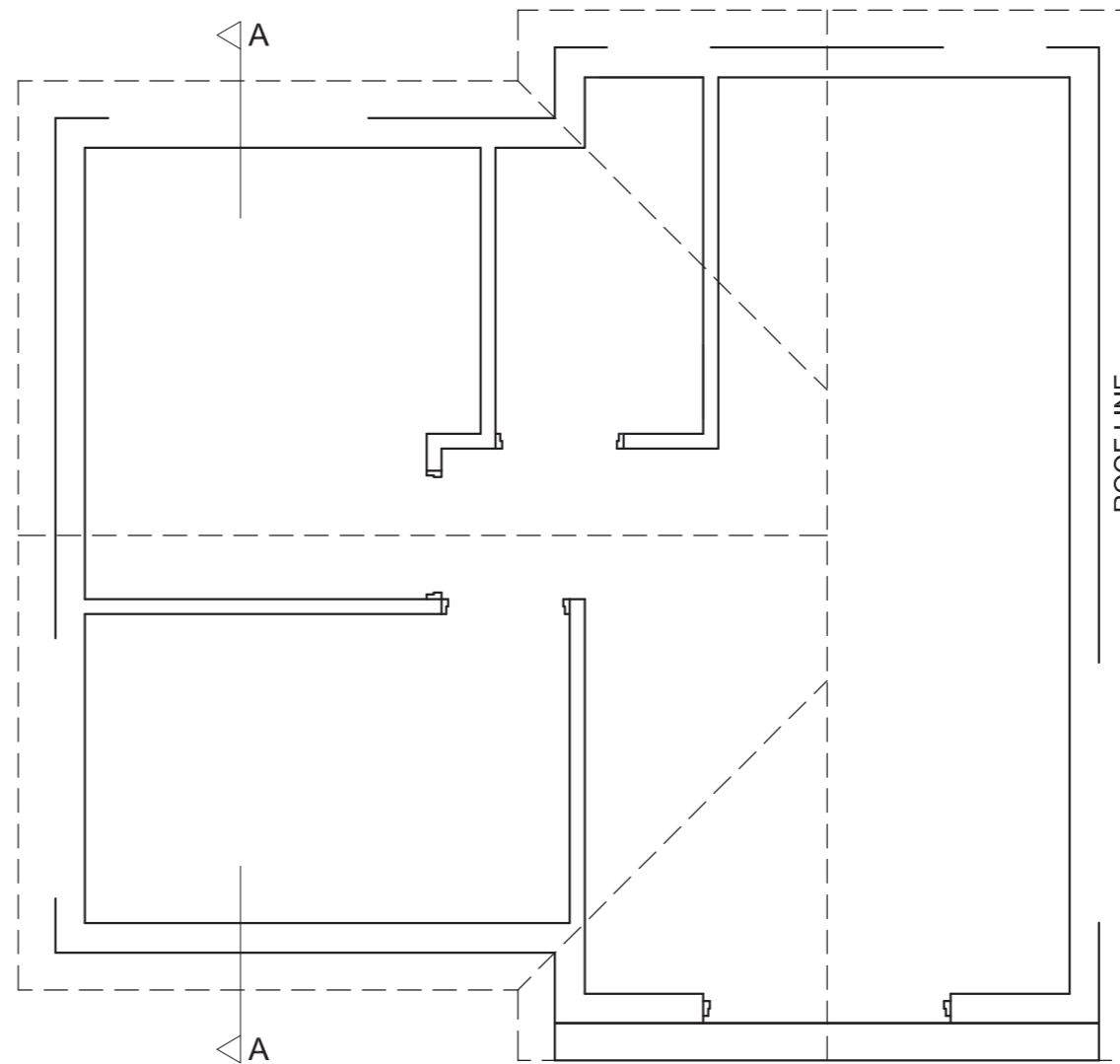

FLOOR PLAN
SCALE 1 : 50

ASSESSMENT CRITERIA					
FLOOR PLAN					
		POSSIBLE	OBTAINED	SIGN	MODERATE
1	LABELS	5			
2	ELECTRICAL	11			
3	FIXTURES	11			
4	DOORS + WINDOWS	15			
5	HATCHING	3			
SUBTOTAL		45			
NORTH ELEVATION					
1	WALLS + FFL + STEP	3			
2	ROOF + FACIA GUTTER + RWDP	6½			
3	DOOR	2			
4	LABELS	1½			
SUBTOTAL		13			
SECTIONAL ELEVATION					
1	ROOF	12			
2	WALLS + FLOOR + FOUNDATION	11½			
3	WINDOWS	7			
4	HATCHING	5			
5	LABELS	2½			
SUBTOTAL		38			
TOTAL		96			
EXAMINATION NUMBER					
EXAMINATION NUMBER					
6					



DOOR AND WINDOW SCHEDULE

NOTE: 175 x 20 FIBRE CEMENT SILL UNDER ALL WINDOWS

WINDOW (W1)
 TO FIT
 2000
 1500
 450
 500
 500

FRONT AND LEFT VIEW OF FRONT DOOR FRAME WITH SIDE PANELS (D2)
 TO FIT
 2100
 1550
 752
 425
 425
 75

INTERNAL DOOR AND FRAME (D1)
 TO FIT
 2100

FRONT DOOR (D2)
 TO FIT
 2100

ROOF COMPONENTS	
75 x 50 PURLINS	
200 x 20 FASCIA BOARD	
114 x 38 WALL PLATE	
125 x 100 GUTTER	
ROOF CAP	

ELECTRICAL SYMBOLS

SANITARY FIXTURES	
WASHBASIN (WB)	TOILET (WC)
BUILT-IN CUPBOARD (BIC)	

SOUTH-EAST ELEVATION

200 x 20 BARGE BOARD
 125 x 100 GUTTER
 Ø100 mm RWDP
 W1 WINDOW
 FRONT DOOR
 FLOOR LEVEL
 GROUND LEVEL

INCOMPLETE FLOOR PLAN

ROOF LINE
 RWDP
 SIDE OPENING HEIGHT 2700 FROM GROUND LEVEL

FIXTURES
 D1 INTERIOR DOOR OPENINGS
 D2 FRONT DOOR OPENING
 W1 WINDOW OPENINGS
 WC TOILET
 WB WASHBASIN
 BIC BUILT-IN CUPBOARD

ELECTRICAL FITTINGS
 1. SINGLE-POLE LIGHT SWITCH
 2. CEILING LIGHT
 3. 2 x 40 W FLUORESCENT TUBES
 4. SWITCH SOCKET OUTLET
NOTE:
 THE ARROW SHOWS THE LIGHT CONNECTION TO THE SWITCH.

ROOF NOTES:
 ROOF COVER 15 mm CORRUGATED IRON ON 75 x 50 mm PURLINS @ 1800 c/c

114 x 38 mm ROOF TRUSSES ON 114 x 38 mm WALL PLATES

ROOF PITCH 20° WITH 200 x 20 mm FASCIA BOARD ON BOTH ENDS

125 x 100 mm GUTTER ON BOTH ENDS

PLASTER CEILING BOARD ON 6 STRIPS OF 38 x 38 mm BRANDING, EVENLY SPACED

SCHEMATIC DIAGRAM OF A ROOF TRUSS

2600
 700
 500
 100
 250
 550
 150
 250

GROUND LEVEL

INCOMPLETE FOUNDATION AND EXTERNAL WALL DETAIL

INCOMPLETE FOUNDATION AND INTERNAL WALL DETAIL

FLOOR FINISH
 ROOM 1: CARPET
 ROOM 2: CARPET
 TOILET: WOOD
 RECEPTION: WOOD

ROOM DESIGNATIONS WITH FLOOR FINISHES

QUESTION 4: CIVIL DRAWING

Given:

- The complete south-east elevation of new **consulting rooms**, showing the walls, the window, the front door, the roof and notes
- The incomplete floor plan, showing the walls, position of the windows, doors, fixtures and the electrical fittings
- Roof notes and a schematic diagram of a roof truss
- Incomplete foundation and wall detail
- The floor finishes and a diagram showing the room designations
- A door and window schedule
- A table of roof components
- A table of electrical symbols
- A table of sanitary fixtures
- The incomplete floor plan of the new **consulting rooms**, drawn to scale 1 : 50, on page 6

Instructions:

- Answer this question on page 6.
- Using the given incomplete floor plan, draw, in first-angle orthographic projection and to scale 1 : 50, the following views of the new **consulting rooms**:
4.1 The complete floor plan
4.2 A sectional elevation on cutting plane A-A
4.3 The north-east elevation
- ALL drawings must comply with the **guidelines** and **graphical symbols** contained in the *SANS 10143*.

SPECIFICATIONS:

THE FLOOR PLAN
Add the following features to the drawing:

- ALL doors and windows
- ALL the sanitary fixtures as indicated by the abbreviations
- ALL the electrical fittings as indicated by the numbers
- ALL hatching detail

THE SECTIONAL ELEVATION

Show the following features on the drawing:

- The complete foundation, wall, slab, roof and ceiling detail
- The window detail, with a double lintel, and the door detail
- The sanitary fixtures
- ALL hatching detail

THE NORTH-EAST ELEVATION

Show the following features on the drawing:

- The outside walls and finished floor level
- The roof detail, including the gutter, fascia board and rain-water downpipe
- The window detail

Label the following:

- The room designations with floor finishes
- The sectional elevation and north-east elevation
- Using the correct abbreviations, label the following features in the correct view: ground level and damp-proof course.

NOTE:

- ALL substructure hatching may be drawn in freehand. **[96]**



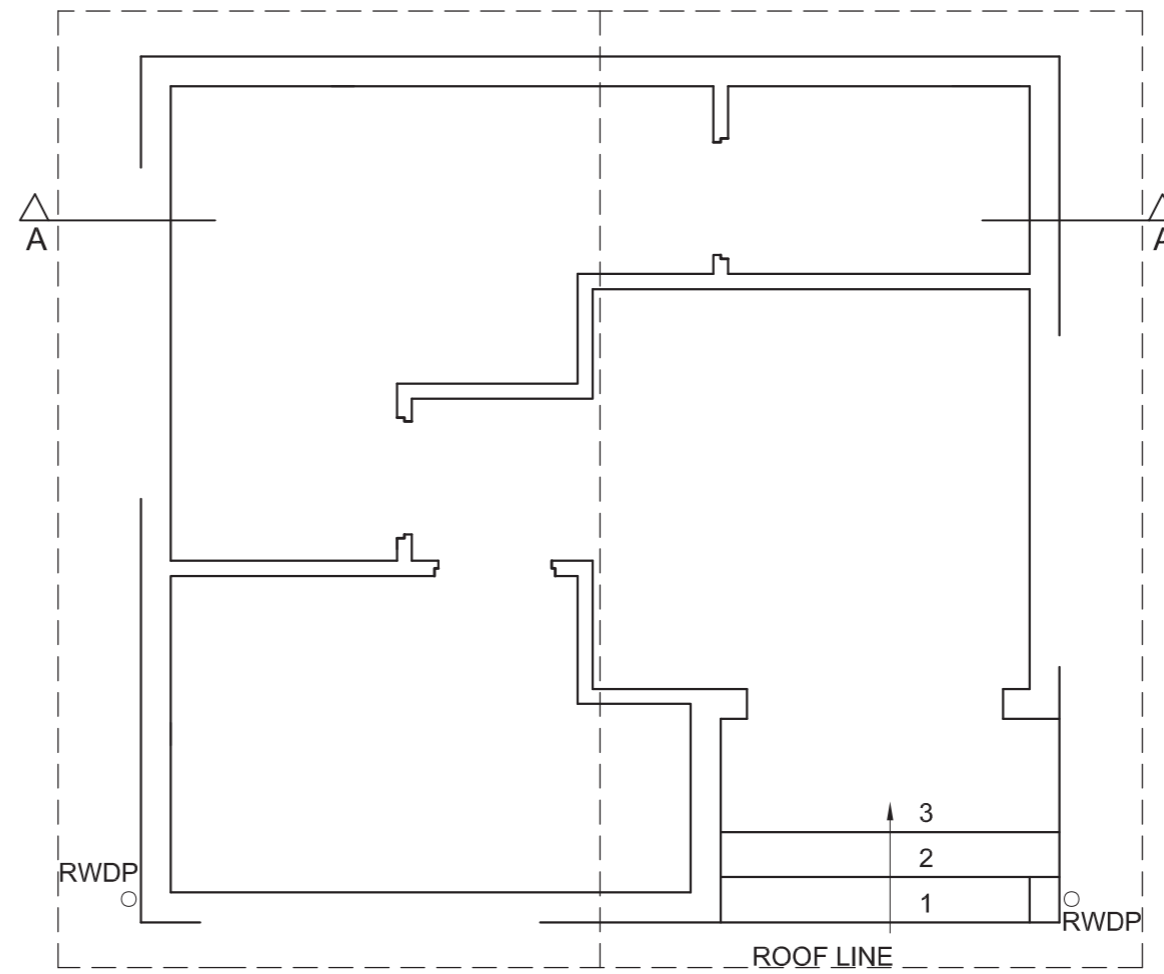

FLOOR PLAN
SCALE 1 : 50

ASSESSMENT CRITERIA					
FLOOR PLAN					
		POSSIBLE	OBTAINED	SIGN	MODERATED
1	LABELS	4			
2	ELECTRICAL	11			
3	FITTINGS	6			
4	DOORS + WINDOWS	14			
5	HATCHING	3			
SUBTOTAL		38			
SECTIONAL ELEVATION					
1	ROOF	16			
2	WALLS + FLOOR + FOUNDATIONS	11			
3	WINDOW	2			
4	LABELS	3			
5	HATCHING	6			
6	FIXTURES	4			
SUBTOTAL		42			
NORTH-EAST ELEVATION					
1	WALLS + FFL	5			
2	ROOF + GUTTER + RWDP	5			
3	WINDOW	5			
4	LABELS	1			
SUBTOTAL		16			
TOTAL		96			
EXAMINATION NUMBER					
EXAMINATION NUMBER					
6					



DOOR AND WINDOW SCHEDULE

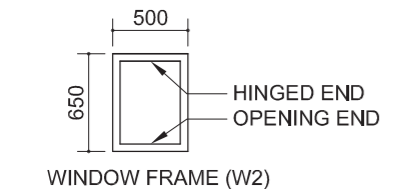
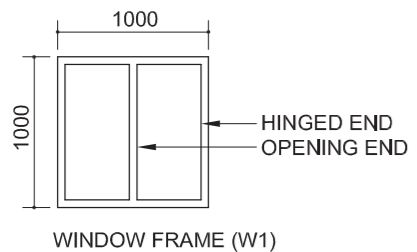
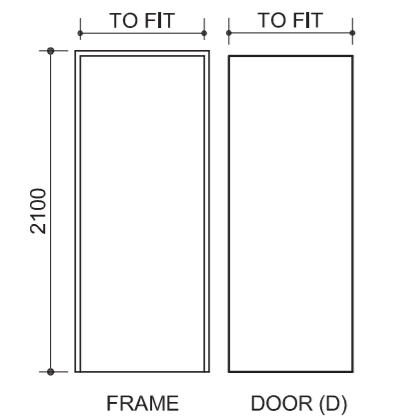

NOTES:
150 x 20 FIBRE CEMENT SILL UNDER ALL WINDOWS

ELECTRICAL SYMBOLS

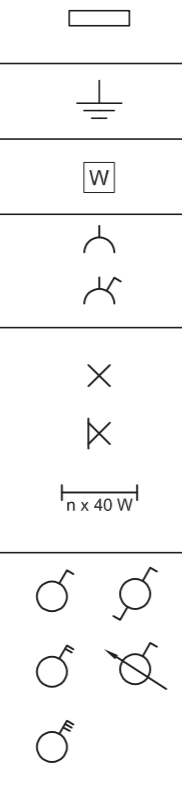

RAINWATER DOWNPIPE

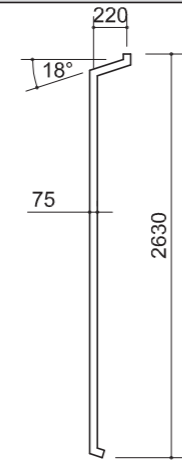

ROOF COMPONENTS

	ROOF CAP
	115 x 38 WALL PLATE
	75 x 50 PURLINS
	100 x 100 GUTTER

DIMENSIONS OF FIXTURES

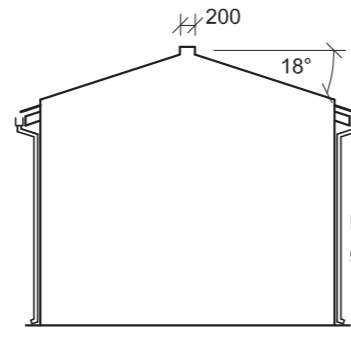
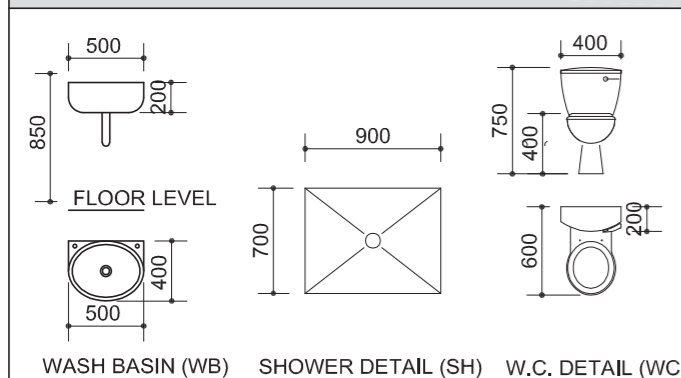

EAST ELEVATION

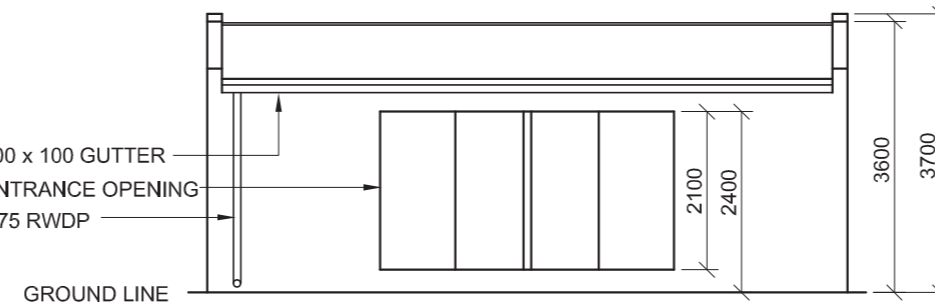

INCOMPLETE SOUTH ELEVATION

FEATURES

- D DOOR
- W1 WINDOW
- W2 WINDOW

FIXTURES

- WC - TOILET
- SH - SHOWER
- WB - WASH BASIN

ELECTRICAL FIXTURES

- LIGHT SWITCH ONE-POLE
- LIGHT SWITCH TWO-POLE
- CEILING LIGHT
- SWITCHED SOCKET OUTLET

NOTE:
THE ARROW SHOWS THE LIGHT CONNECTION TO THE SWITCH

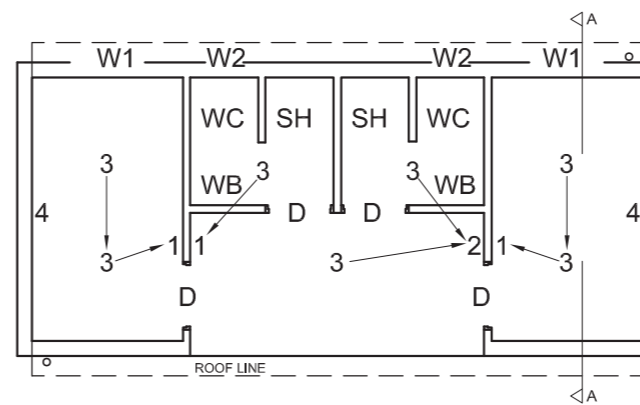

INCOMPLETE FLOOR PLAN

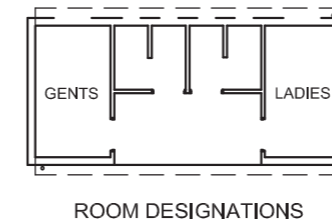

ROOM DESIGNATIONS

ROOF NOTES:

ROOF COVER 15 mm FIBRE CEMENT SHEET ON 75 x 50 mm PURLINS @ 700 mm c/c.

115 x 38 mm ROOF TRUSS ON 115 x 38 mm WALL PLATE.

ROOF PITCH 18°.

100 mm SQUARE GUTTER ON BOTH ENDS.

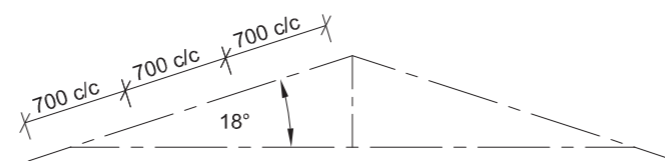

SCHEMATIC DIAGRAM OF A ROOF TRUSS

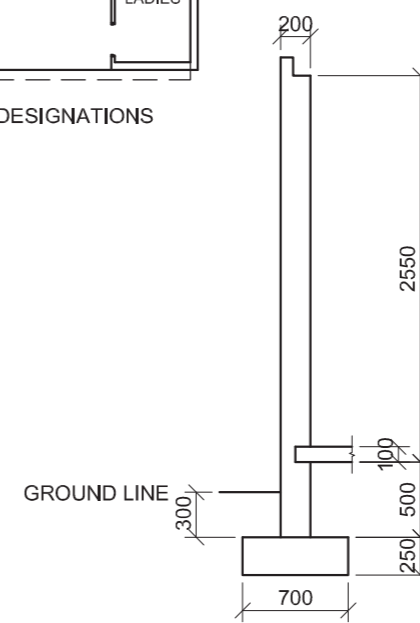

INCOMPLETE FOUNDATION, SLAB AND WALL DETAIL ON A-A

QUESTION 4: CIVIL DRAWING

Given:

- The incomplete south elevation of a new **change room**, showing the walls, the entrance opening, the roof, dimensions and notes
- The incomplete floor plans showing the walls, position of the doors, the windows, the fixtures, the electrical features and room designations
- The complete east elevation
- Roof notes and a schematic diagram of a roof truss
- The incomplete foundation, slab and wall detail
- A door and window schedule
- A table of electrical symbols
- A table of roof components and the rainwater downpipe
- A table of fixtures
- The incomplete plan of the new **change room**, drawn to scale 1 : 50, on page 6

Instructions:

- Answer this question on page 6.
- Using the given incomplete floor plan, draw to scale 1:50 and in first-angle orthographic projection, the following views of the new **change room**:
 - The complete floor plan
 - The south elevation
 - A sectional elevation on cutting plane A-A
- ALL drawings must comply with the **guidelines** and **conventions** contained in the *SABS 0143*.

SPECIFICATIONS:

THE FLOOR PLAN

Add the following features to the drawing:

- ALL the doors and windows
- ALL fixtures as indicated by abbreviations
- ALL electrical features as indicated by numbers
- ALL hatching detail

THE SOUTH ELEVATION

Show the following features on the drawing:

- The outside walls
- The roof detail including the gutter and rainwaterdown pipe
- ALL visible detail through the front entrance opening with the internal doors open
- The finished floor level

THE SECTIONAL ELEVATION

Show the following features on the drawing:

- The complete foundation, wall, slab and roof detail
- The window detail with a double lintel above the window
- ALL features to the west of the cutting plane A-A
- ALL hatching detail

Label the following:

- The room designations and floor finish (tile)
- The south elevation and the sectional elevation
- Using correct abbreviations, label the following features in the correct view: ground level, finished floor level and damp-proof course.

NOTE:

- ONLY the substructure hatching may be drawn in freehand.



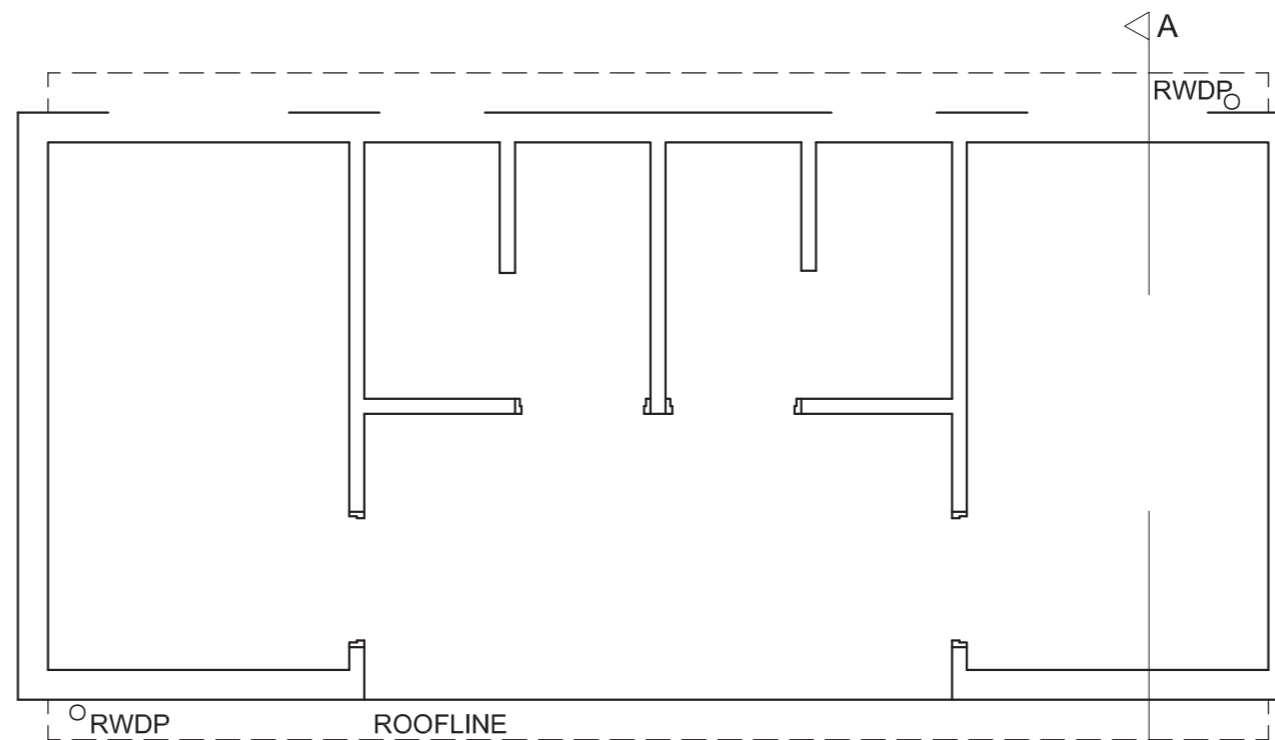

PLAN
SCALE 1:50

ASSESSMENT CRITERIA					
PLAN					
		POSSIBLE	OBTAINED	SIGN	MODERATE
1	LABELS	2			
2	ELECTRICAL	10			
3	FIXTURES	6			
4	DOORS + WINDOWS	14			
5	HATCHING	4			
SUBTOTAL		36			
SOUTH ELEVATION					
1	WALLS + FFL + DOOR + SH	11			
2	ROOF + GUTTER + RWDP	3			
3	LABELS	2			
SUBTOTAL		16			
SECTIONAL ELEVATION					
1	ROOF	15			
2	WALLS + FLOOR + FOUNDATION	13			
3	WINDOW + DOOR + FIXTUR's	5			
4	HATCHING	6			
5	LABELS	3			
SUBTOTAL		42			
TOTAL		94			
EXAMINATION NUMBER					
EXAMINATION NUMBER					
				6	



ELECTRICAL SYMBOLS	

ROOF COMPONENTS	
	75 x 50 PURLINS
	115 x 38 WALL PLATE
	ROOF CAP
	200 x 12 FASCIA BOARD

DOOR AND WINDOW SCHEDULE

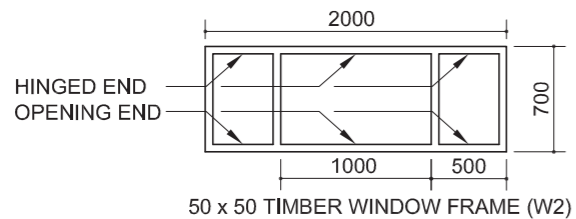
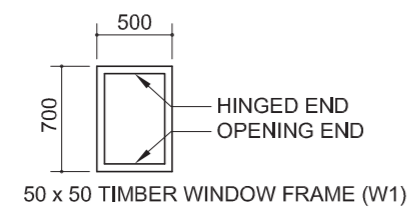
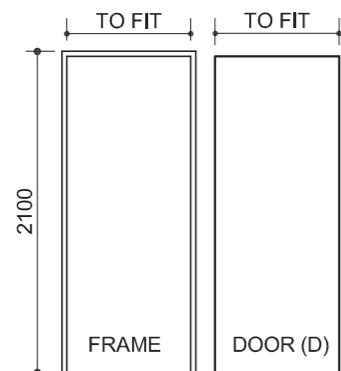

DIMENSIONS OF FIXTURES

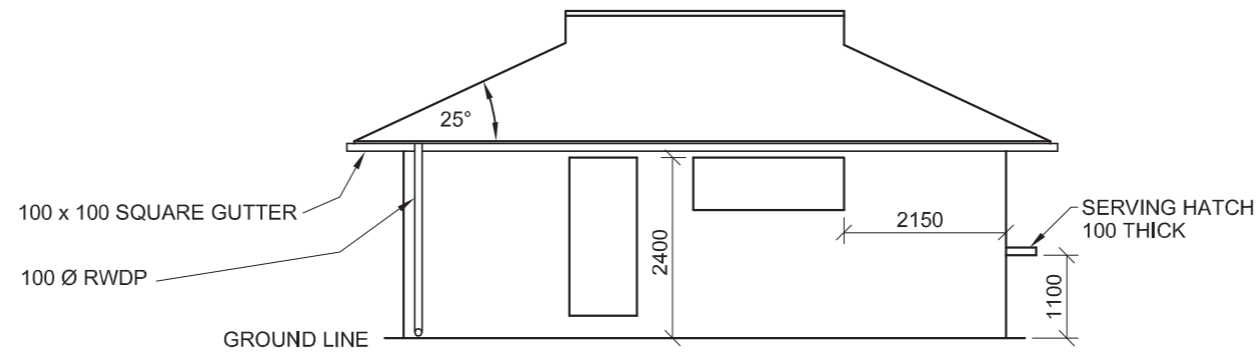
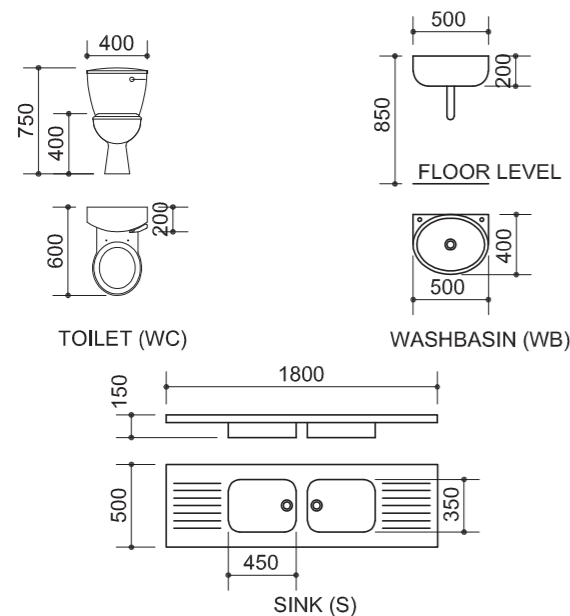

INCOMPLETE WEST ELEVATION

FEATURES

- D - DOOR
- W1 - WINDOW
- W2 - WINDOW

FIXTURES

- WC - TOILET
- S - SINK
- WB - WASHBASIN

ELECTRICAL FITTINGS

1. SINGLE-POLE LIGHT SWITCH
2. TWO-POLE LIGHT SWITCH
3. 3 x 40 W FLUORESCENT TUBES
4. CEILING LIGHT
5. OUTSIDE LIGHT
6. SWITCHED SOCKET OUTLET
7. DISTRIBUTION BOARD

NOTE:
THE ARROWS SHOW THE LIGHT CONNECTION TO THE SWITCH.

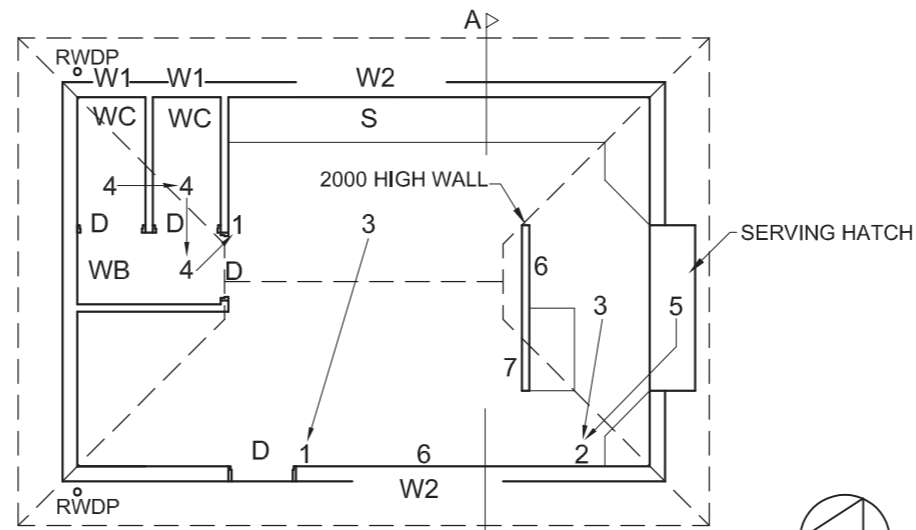

INCOMPLETE FLOOR PLAN

ROOF NOTES:

ROOF COVER 15 mm CORRUGATED IRON SHEET ON 75 x 50 mm PURLINS @ 1100 c/c

ROOF PITCH 25°

115 x 38 mm ROOF TRUSS ON 115 x 38 mm WALL PLATE

6 mm PLASTER BOARD ON 38 x 38 mm BRANDING @ 1000 c/c

100 mm SQUARE GUTTER AROUND THE BUILDING

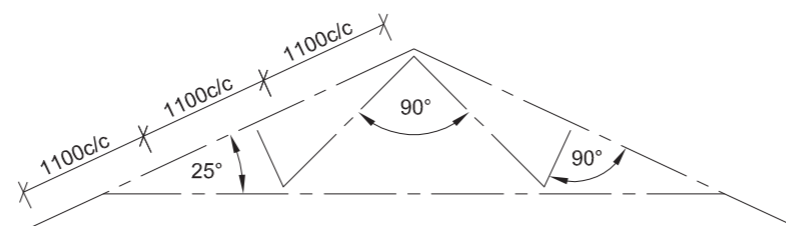

SCHMATIC DIAGRAM OF A ROOF TRUSS

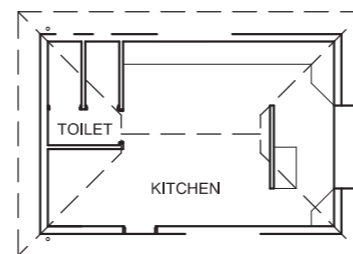

ROOM DESIGNATIONS

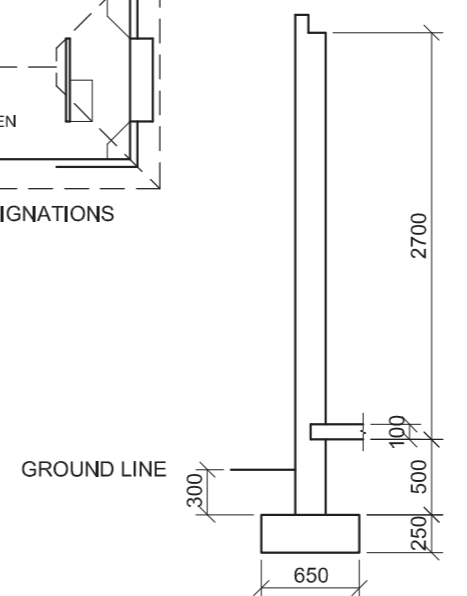

INCOMPLETE FOUNDATION AND WALL DETAIL ON A-A

QUESTION 4: CIVIL DRAWING

Given:

- The incomplete west elevation of a new **kitchen and tuck shop** showing the walls, the position of the window, the door, the roof, dimensions and notes
- The incomplete floor plan showing the walls, position of the windows, doors, fixtures and electrical features
- Roof notes and a schematic diagram of a roof truss
- The incomplete foundation and wall detail on cutting plane A-A
- A table of electrical symbols
- A table of roof components
- A door and window schedule
- A table of fixtures
- The incomplete floor plan of the new **kitchen and tuck shop**, drawn to scale 1 : 50, on page 6

Instructions:

- Answer this question on page 6.
- Using the given incomplete floor plan, draw in first-angle orthographic projection and to scale 1 : 50, the following views of the new **kitchen and tuck shop**:
 - 4.1 The complete floor plan**
 - 4.2 A sectional elevation** on cutting plane A-A
 - 4.3 The west elevation**
- ALL drawings must comply with the **guidelines** and **conventions** contained in the *SABS 0143*.

SPECIFICATIONS:

THE FLOOR PLAN

Add the following features to the drawing:

- ALL doors and windows
- ALL fixtures as indicated by the abbreviations
- ALL electrical fittings as indicated by the numbers
- ALL hatching detail

THE WEST ELEVATION

Show the following features on the drawing:

- The outside walls
- The roof detail, including the gutter and rainwater downpipe
- The window and door detail
- The finished floor level

THE SECTIONAL ELEVATION

Show the following features on the drawing:

- The complete foundation, wall and roof detail
- The window detail with a double lintel above the window
- The internal wall to the south of cutting plane A-A **ONLY**
- ALL hatching detail

Label the following:

- The room designations and floor finish (tile)
- The west elevation and the sectional elevation
- Using correct abbreviations, label the following features in the correct view: ground level, finished floor level and damp-proof course.

NOTE:

ONLY the substructure hatching may be drawn in freehand.

[94]





NGL _____

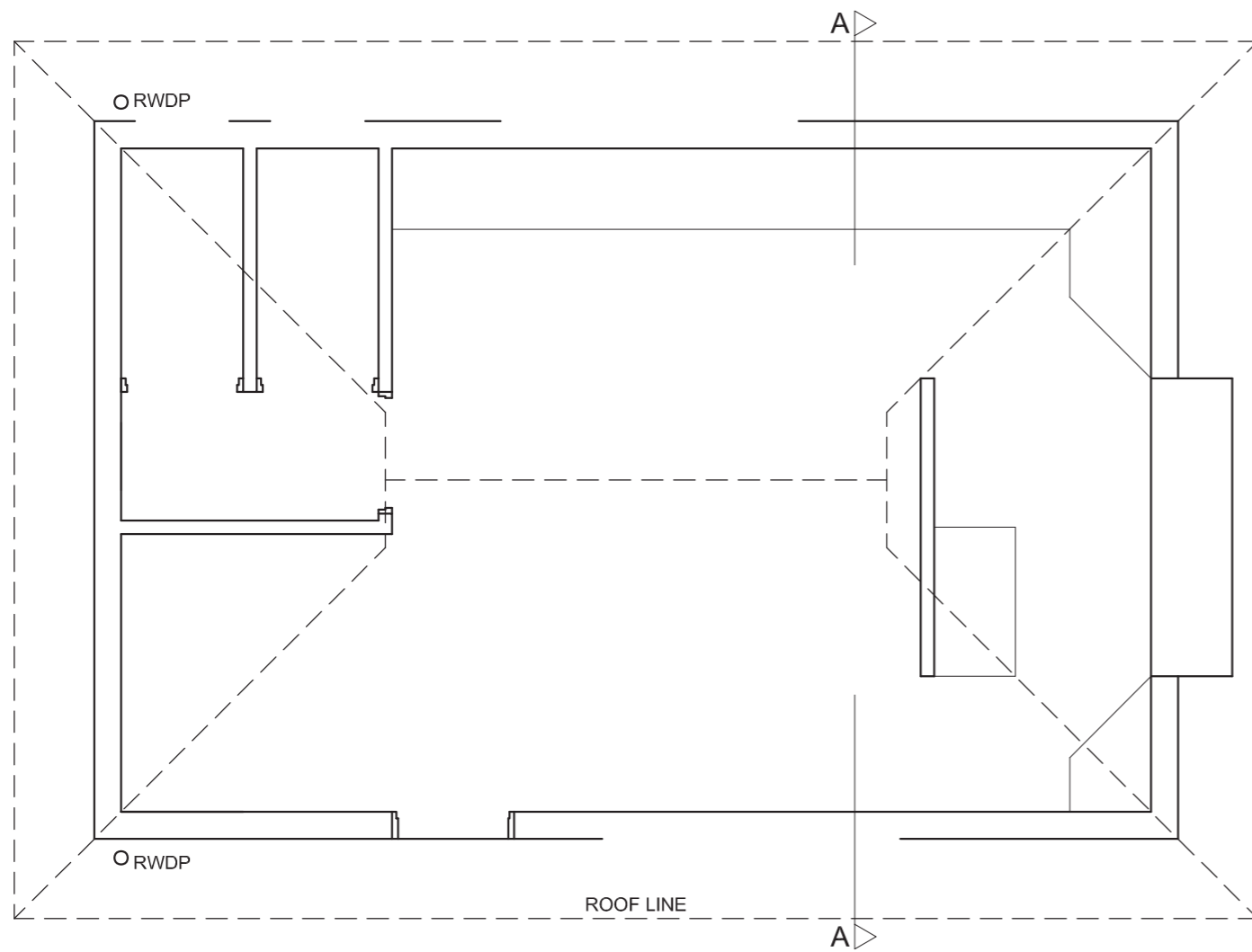

FLOOR PLAN
SCALE 1 : 50

ASSESSMENT CRITERIA				
FLOOR PLAN				
1	ELECTRICAL	9		
2	HATCHING	5		
3	DOORS + WINDOWS	14		
4	FIXTURES	4		
5	LABELS	2		
SUBTOTAL		34		
WEST ELEVATION				
1	WALLS + FFL + SERV HATCH	3½		
2	ROOF + GUTTER +RWDP	7		
3	DOOR + WINDOW	6		
4	LABELS	1½		
SUBTOTAL		18		
SECTIONAL ELEVATION				
1	ROOF + CEILING	18		
2	WALLS + FLOOR + FOUNDATION	13		
3	WINDOW	3		
4	HATCHING	5		
5	LABELS	3		
SUBTOTAL		42		
TOTAL		94		
EXAMINATION NUMBER				
EXAMINATION NUMBER				
				6



ELECTRICAL SYMBOLS	ROOF COMPONENTS
	75 x 50 PURLINS
	228 x 20 FASCIA BOARD
	114 x 38 WALL PLATE

FIXTURES

Dimensions:

- BATH TUB (B): 1700 x 370
- TOILET (WC): 450 x 780
- SINK (S): 450 x 875
- WASHBASIN (WB): 400 x 550
- BUILT-IN CUPBOARD (BIC): TO FIT x 600

DOOR AND WINDOW SCHEDULE

WINDOW (W1): 1000 x 1000

WINDOW (W2): 2000 x 1000

NOTE: 150 x 20 FIBRE CEMENT SILL UNDER ALL WINDOWS

SLIDING DOOR AND FRAME (D2): 2100 x TO FIT

DOOR AND FRAME (D): 2100 x TO FIT

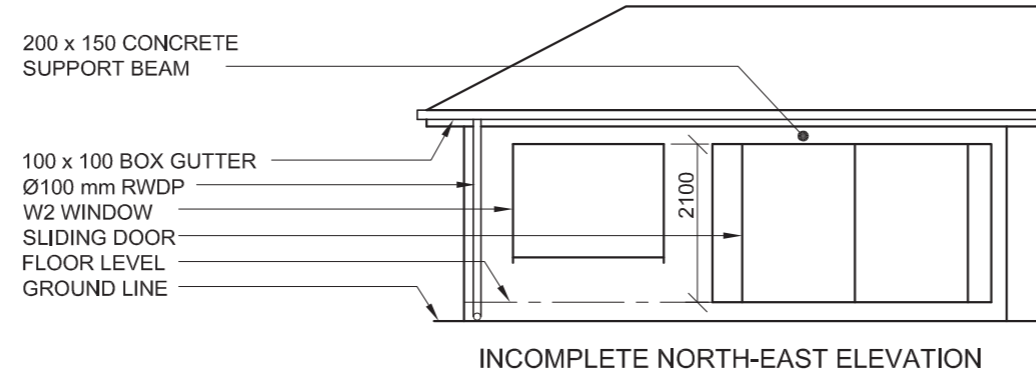

- FIXTURES**
- D1 HINGED DOOR OPENINGS
 - D2 SLIDING DOOR OPENING
 - W1, W2 WINDOW OPENINGS
 - B BATH
 - S SINK
 - WC TOILET
 - WB WASHBASIN
 - BIC BUILT-IN CUPBOARD

- ELECTRICAL FIXTURES**
- THREE-POLE LIGHT SWITCH
 - SINGLE-POLE LIGHT SWITCHES
 - CEILING LIGHT
 - 2 x 40 W FLUORESCENT TUBES
 - SWITCH SOCKET OUTLETS
- NOTE:** THE ARROW SHOWS THE LIGHT CONNECTION TO THE SWITCH.

ROOF NOTES:

ROOF COVER 15 mm CORRUGATED IRON ON 75 x 50 mm PURLINS @ 1450 c/c.

114 x 38 mm ROOF TRUSSES ON 114 x 38 mm WALL PLATES.

ROOF PITCH 30° WITH 228 x 20 mm FASCIA BOARD ON BOTH ENDS.

100 mm SQUARE BOX GUTTER

PLASTER CEILING BOARD ON 4 STRIPS OF 38 x 38 mm BRANDERING, EVENLY SPACED

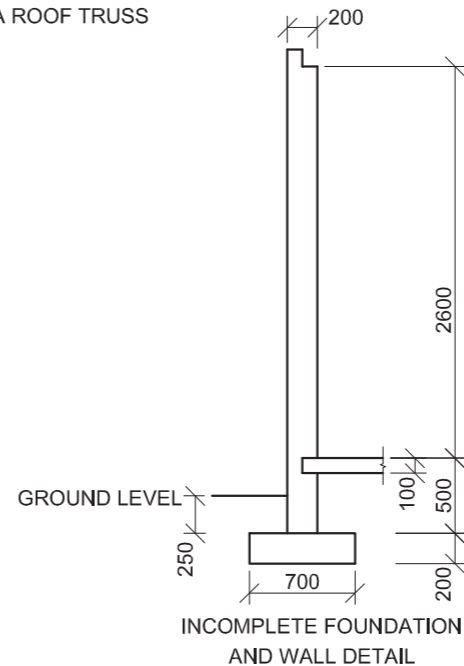
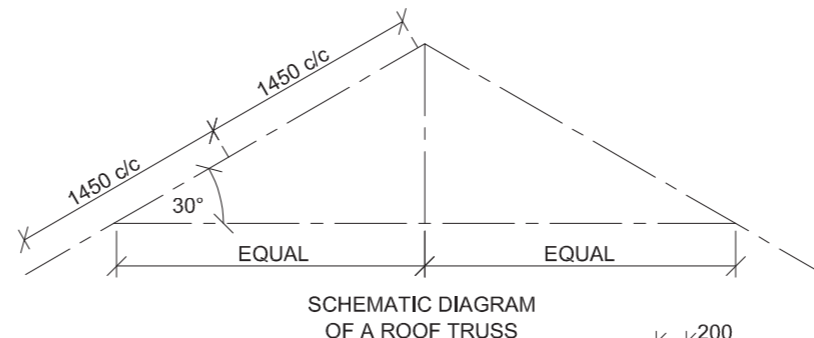
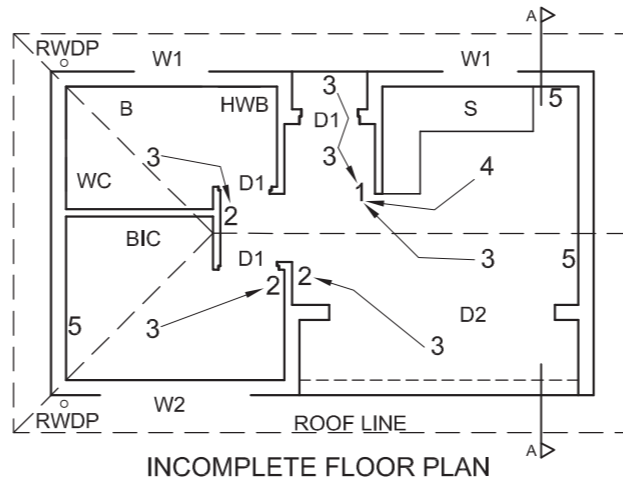
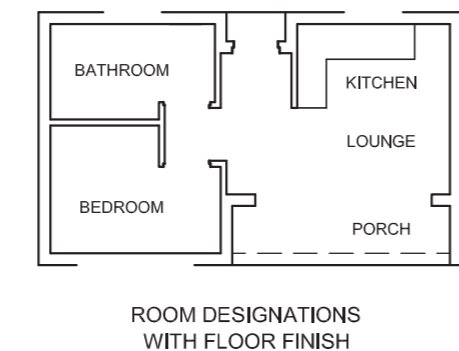

QUESTION 4: CIVIL DRAWING

Given:

- The incomplete north-east elevation of a new **cottage** showing the walls, the position of the windows, sliding door, the roof and notes
- The incomplete floor plan showing the walls, position of the windows, doors, fixtures and the electrical fixtures
- Roof notes and a schematic diagram of a roof truss
- A diagram showing the room designations and floor finishes
- The incomplete foundation and wall detail
- A table of electrical symbols
- A table of roof components
- A table of fixtures
- A door and window schedule
- The incomplete floor plan of the new **cottage**, drawn to scale 1 : 50, on page 6

Instructions:

- Answer this question on page 6.
- Using the given incomplete floor plan, draw, to scale 1 : 50 and to the specifications, the following views of the new **cottage**:
 - 4.1 The complete floor plan
 - 4.2 The north-east elevation
 - 4.3 A sectional elevation on cutting plane A-A
- ALL drawings must comply with the guidelines and conventions contained in the *SABS 0143*.

SPECIFICATIONS:

- THE FLOOR PLAN**
- Add the following features to the drawing:**
- ALL doors and windows. Show the direction of opening for the sliding door.
 - ALL fixtures as indicated by the abbreviations
 - ALL the electrical fixtures as indicated by the numbers
 - ALL hatching detail

- THE NORTH-EAST ELEVATION**
- Show the following features on the drawing:**
- The outside walls
 - The roof detail including the gutter, fascia board and rainwater downpipe
 - The window and sliding door detail including all the directions of opening

- THE SECTIONAL ELEVATION**
- Show the following features on the drawing:**
- The complete foundation, wall, slab, roof and ceiling detail
 - The sliding door detail
 - ALL hatching detail

- Label the following:**
- The north-east elevation and the sectional elevation
 - The room designations with floor finishes
 - Using the correct abbreviations, label the following features in the correct view: ground level and damp-proof course.

NOTE:

- ALL substructure hatching may be drawn in freehand. [96]



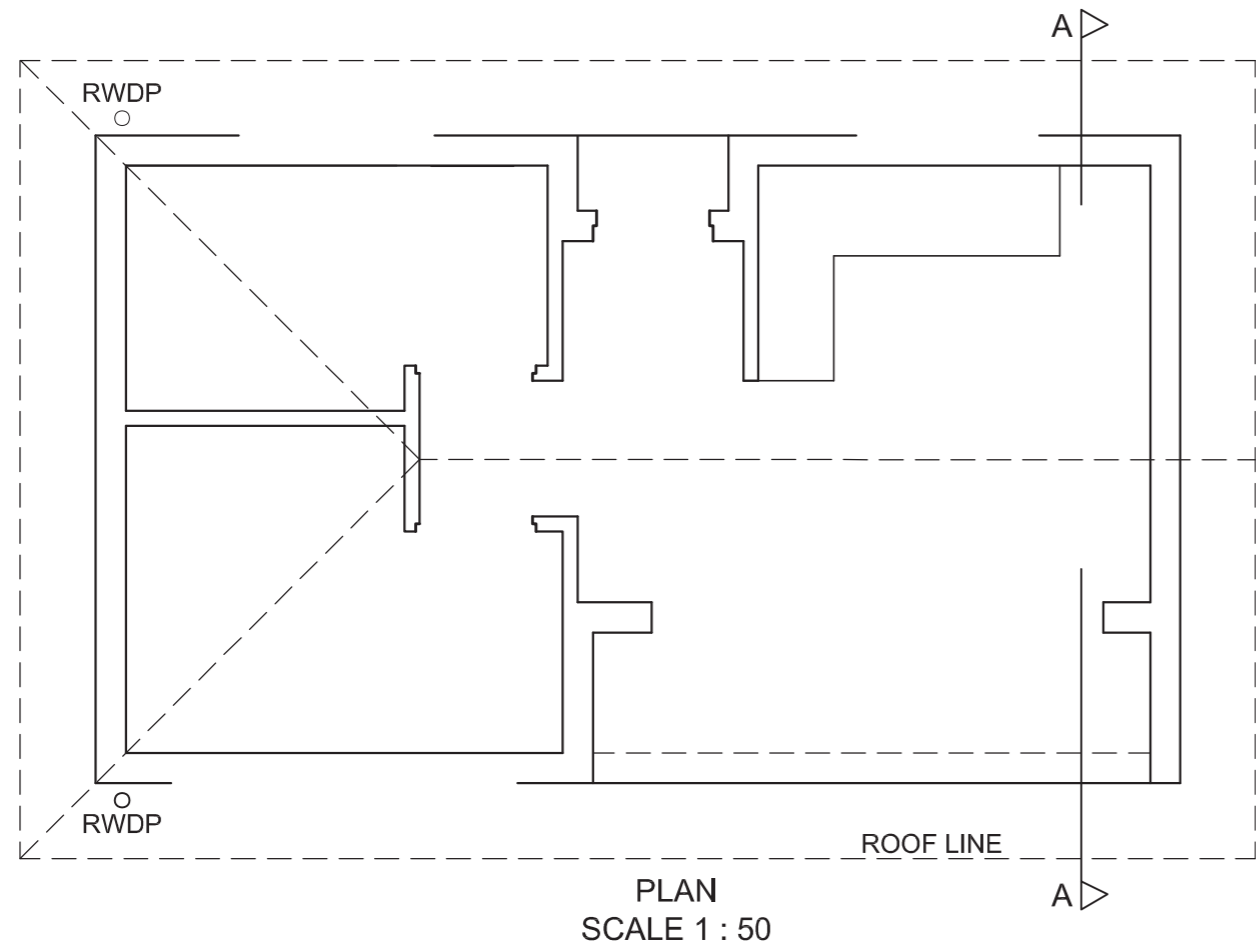

ASSESSMENT CRITERIA				
FLOOR PLAN				
1	LABELS	5		
2	ELECTRICAL	8		
3	FITTINGS	6		
4	DOORS + WINDOWS	12		
5	HATCHING	6		
SUBTOTAL		37		
NORTH-EAST ELEVATION				
1	WALLS + FFL	4		
2	ROOF + GUTTER + RWDP	6 $\frac{1}{2}$		
3	WINDOWS + DOOR	9		
4	LABELS	1 $\frac{1}{2}$		
SUBTOTAL		21		
SECTIONAL ELEVATION				
1	ROOF	13		
2	WALLS + FLOOR + FOUNDATIONS	15 $\frac{1}{2}$		
3	SLIDING DOOR	1		
4	LABELS	1 $\frac{1}{2}$		
5	HATCHING	7		
SUBTOTAL		38		
TOTAL		96		
EXAMINATION NUMBER				
EXAMINATION NUMBER				6



ROOF COMPONENTS	
	75 x 50 PURLINS
	228 x 20 FASCIA BOARD
	114 x 38 WALL PLATE

DOOR SCHEDULE	
TO FIT	TO FIT
FRAME	HOLLOW CORE DOOR (D)

WINDOW SCHEDULE	
	HINGED END
500	700
WOODEN FRAME (W1)	
NOTE: 150 x 20 FIBRE CEMENT SILL UNDER ALL WINDOWS	

DIMENSIONS OF SANITARY FIXTURES	
TOILET (WC)	WASHBASIN (WB)
BATH TUB (B)	SHOWER (SH)

ELECTRICAL SYMBOLS	

ROOF NOTES:
 ROOF COVER 15 mm FIBRE CEMENT BOARD ON 75 x 50 mm PURLINS @ 1200 c/c

114 x 38 mm ROOF TRUSSES ON 114 x 38 mm WALL PLATE

228 x 20 mm FASCIA BOARD ON BOTH ENDS

ROOF PITCH 15°

100 mm SQUARE BOX GUTTER

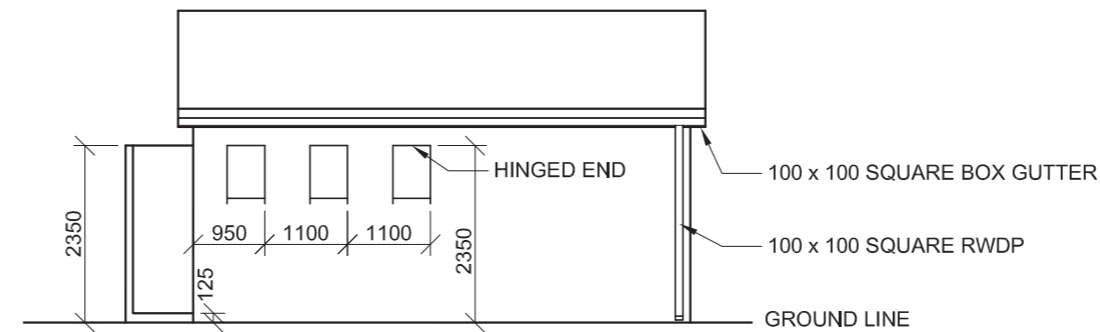

INCOMPLETE NORTH ELEVATION

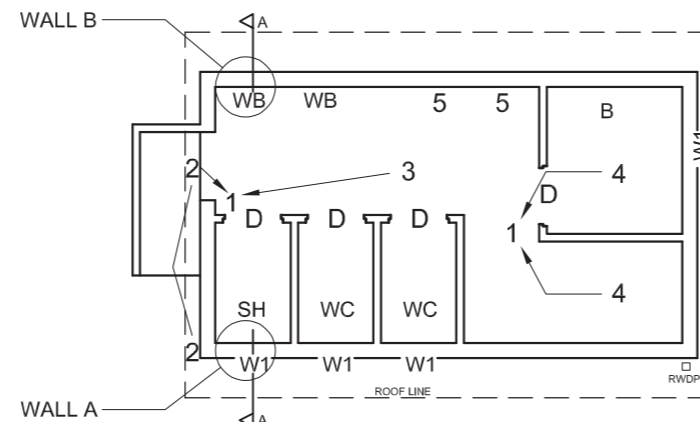

INCOMPLETE FLOOR PLAN

- FIXTURES**
- D DOORS
 - W1 WINDOW OPENINGS
 - B BATH
 - SH SHOWER
 - WC TOILET
 - WB WASHBASIN

- ELECTRICAL FIXTURES**
1. TWO-POLE LIGHT SWITCH
 2. OUTSIDE LIGHT
 3. 2 x 40 W FLUORESCENT TUBES
 4. CEILING LIGHT
 5. SWITCH SOCKET OUTLET
- NOTE: THE ARROWS SHOW THE LIGHT CONNECTION TO THE SWITCH.**

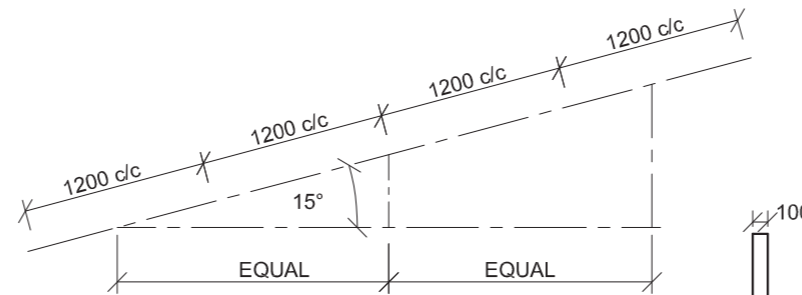

SCHEMATIC DIAGRAM OF A ROOF TRUSS

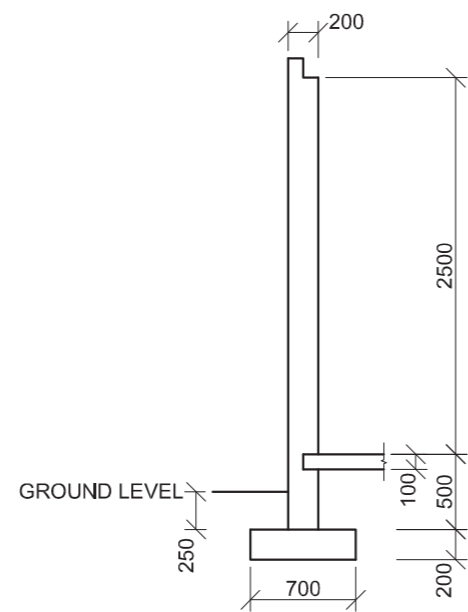

INCOMPLETE FOUNDATION AND WALL 'A' DETAIL ON A-A

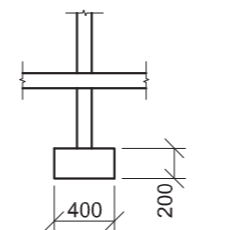

INCOMPLETE FOUNDATION AND INTERNAL WALL DETAIL

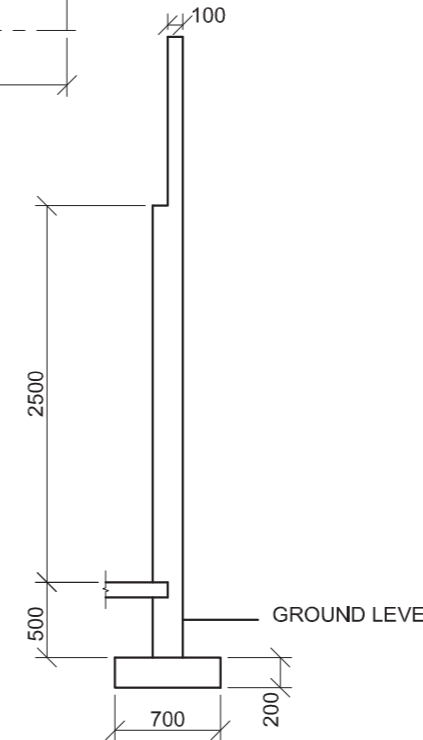

INCOMPLETE FOUNDATION AND WALL 'B' DETAIL ON A-A

QUESTION 4: CIVIL DRAWING

Given:

- The incomplete north elevation of a new **ablution block** for a campsite showing the walls, the position of the windows, the roof and notes
- The incomplete floor plan showing the walls, position of the windows, doors, sanitary fixtures and the electrical fixtures
- Roof notes and a schematic diagram of a roof truss
- The incomplete foundation and wall detail of wall 'A' and wall 'B' on cutting plane A-A
- A table of roof components
- A door and window schedule
- A table of electrical symbols
- A table of sanitary fixtures
- The incomplete floor plan of the new **ablution block**, drawn to scale 1 : 50, on page 6

Instructions:

- Answer this question on page 6.
- Using the given incomplete floor plan, draw, to scale 1 : 50 and to the specifications, the following views of the new **ablution block**:
 - 4.1 The complete floor plan**
 - 4.2 The north elevation**
 - 4.3 A sectional elevation** on cutting plane A-A
- ALL drawings must comply with the guidelines and conventions contained in the *SABS 0143*.

SPECIFICATIONS:

THE FLOOR PLAN

Add the following features to the drawing:

- ALL the doors and windows
- The sanitary fixtures as indicated with the abbreviations
- ALL the electrical fixtures as indicated with the numbers

THE NORTH ELEVATION

Show the following features on the drawing:

- The outside walls
- The roof detail including the gutter, fascia board and rainwater downpipe
- The window detail
- The finished floor level

THE SECTIONAL ELEVATION

Show the following features on the drawing:

- The complete foundation, wall, slab and roof detail
- The window, with a single lintel, and door detail
- ALL features and fixtures on and to the east of cutting plane A-A
- ALL hatching detail

Label the following:

- The floor plan, including the scale
- The room designation and floor finish (ceramic tile)
- The north elevation and the sectional elevation
- Using the correct abbreviations, label the following features in the correct view: ground level, finished floor level and damp-proof course.

NOTE:

- ALL substructure hatching may be drawn in freehand. **[95]**



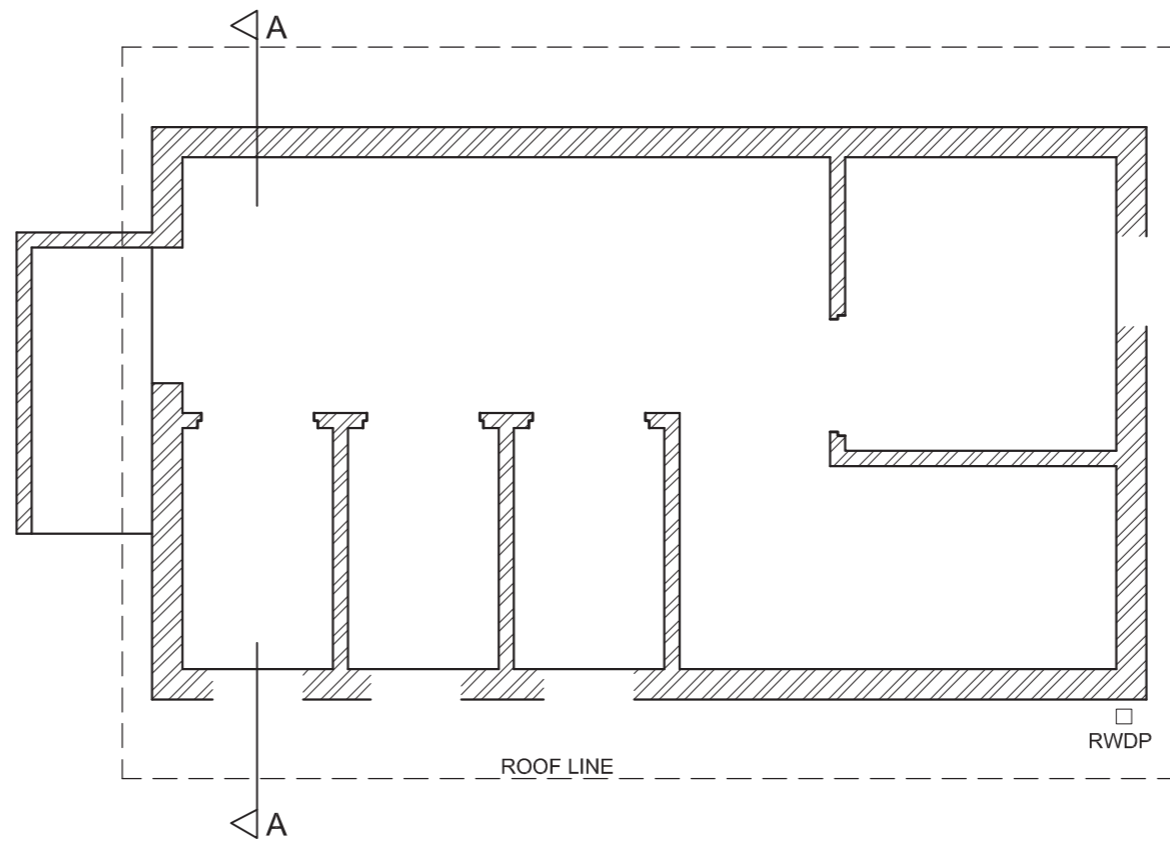

ASSESSMENT CRITERIA				
FLOOR PLAN				
1	LABELS	2		
2	ELECTRICAL	7		
3	FIXTURES	8		
4	DOORS + WINDOWS	14		
SUBTOTAL		31		
NORTH ELEVATION				
1	WALLS + FFL	4		
2	ROOF + FACIA + GUTTER + RWDP	5		
3	WINDOWS	10½		
4	LABELS	1½		
SUBTOTAL		21		
SECTIONAL ELEVATION				
1	ROOF	11		
2	WALLS + FLOOR + FOUNDATION	14½		
3	WINDOW + DOORS + FIXTURES	8		
4	HATCHING	7		
5	LABELS	2½		
SUBTOTAL		43		
TOTAL		95		
EXAMINATION NUMBER				
EXAMINATION NUMBER				6



DOOR AND WINDOW SCHEDULE

DOOR FRAME
STANDARD, EXTERNAL,
MILD STEEL

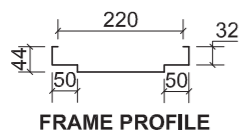

WINDOW
STANDARD W0609
TIMBER FRAME

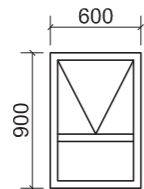

DOOR
H/W FRAMED, LEDGED
AND BATTENED

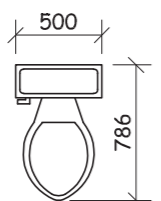
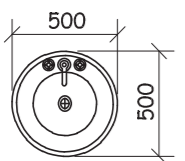
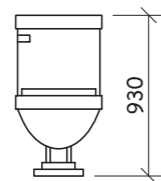
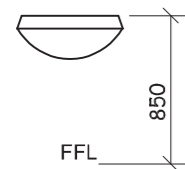
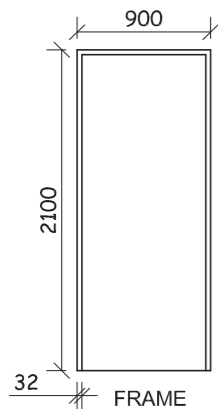
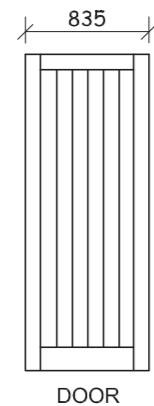

ELECTRICAL SYMBOLS

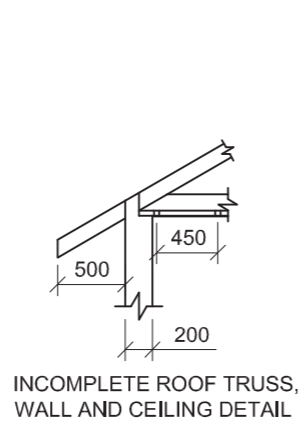
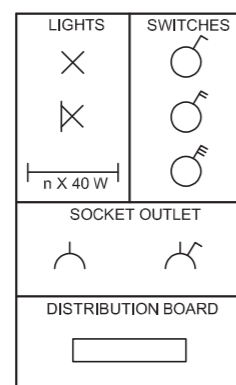

ROOF NOTE
37 x 740 IBR SHEETS LAID
ON 75 x 50 PURLINS @
1250 C/C ON 114 x 38 ROOF
TRUSSES

114 x 38 mm GANG-NAILED
ROOF TRUSS ON A
114 x 38 mm WALL PLATE

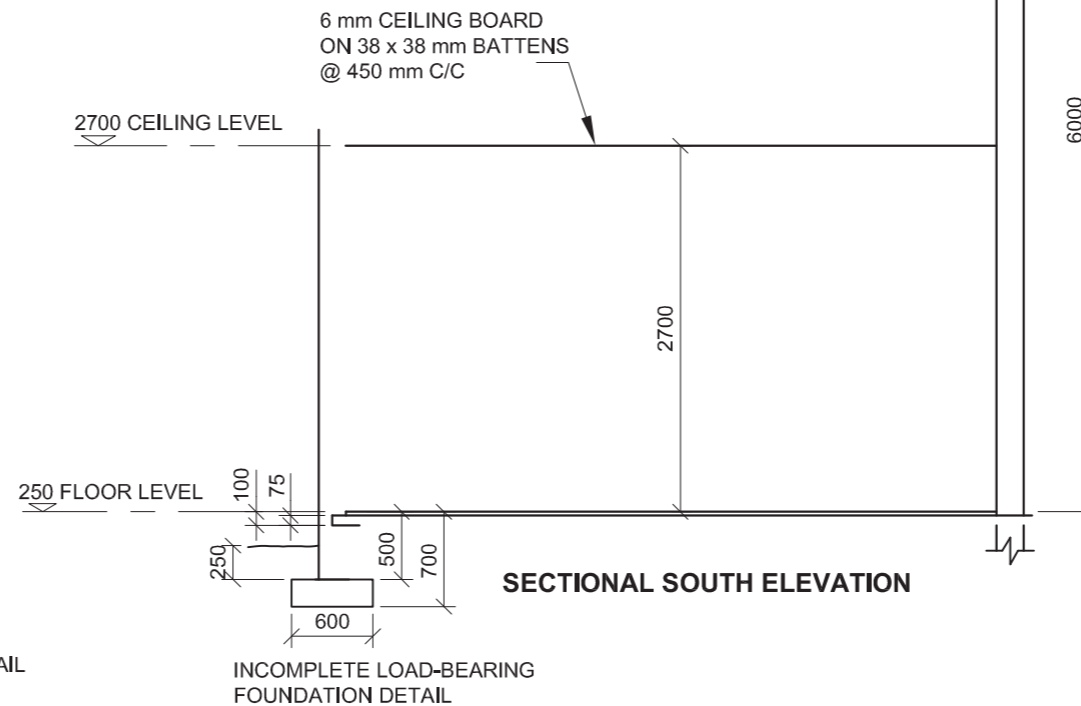
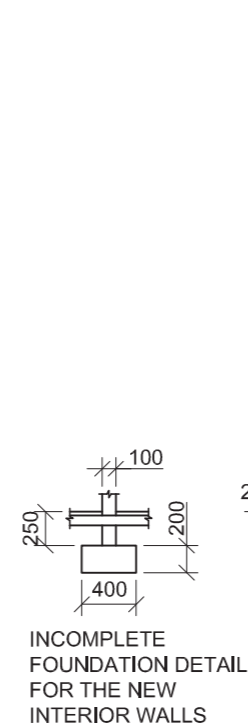
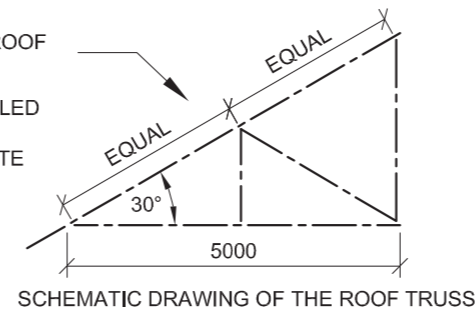

KEY TO NUMBERED FEATURES ON PLAN

- DOUBLE INSULATED SWITCH
- 2 x 40 W FLUORESCENT TUBES
- OUTSIDE LIGHTS
- TWO-POLE LIGHT SWITCH
- TOILET
- SHOWER
- WASH BASIN



OUTSIDE LINE OF
EXISTING 200 mm
LOAD-BEARING BRICK
WALLS

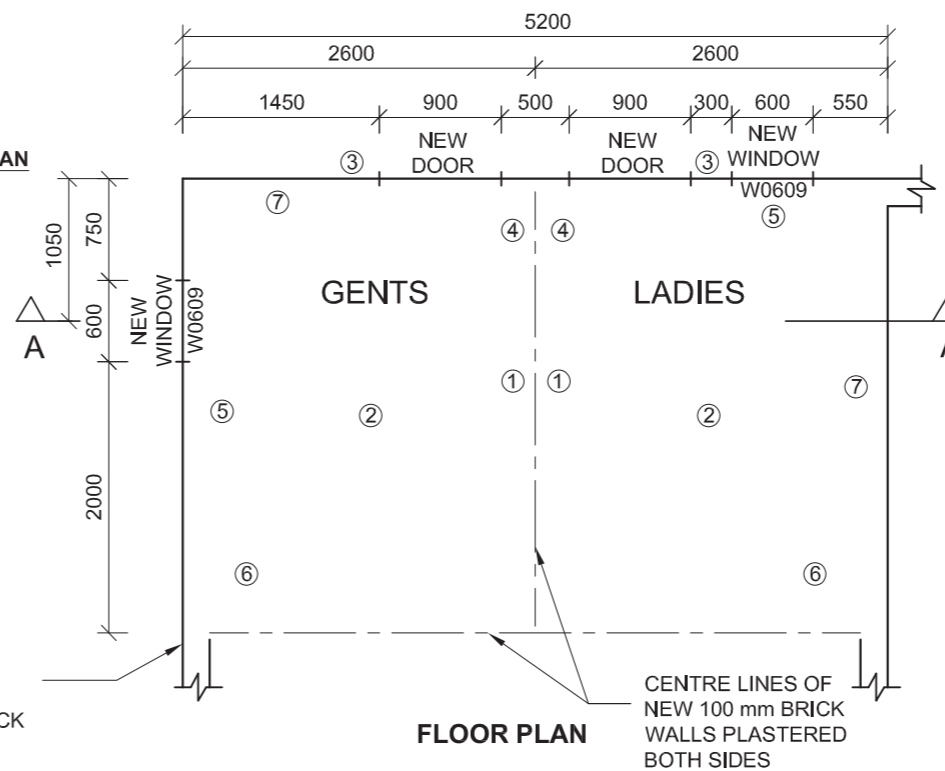

QUESTION 4: CIVIL DRAWING

Given:

- The incomplete sectional south elevation of a part of an previous extension to a clubhouse showing the outside line of the existing outer wall, the incomplete load-bearing foundation detail, the ceiling level and an existing 200 mm load-bearing wall
- The incomplete floor plan of proposed new **ladies and gents change rooms**, that will be developed inside the given part of the previous extension, showing the outside lines of the exterior walls, the centre lines of the new interior walls, the position of all the fixtures and features, relevant notes and dimensions
- A door and window schedule
- The fixtures for the change rooms
- A table of electrical symbols
- The incomplete roof truss, wall and ceiling detail
- A schematic drawing of the roof truss, drawn to a different scale
- The incomplete foundation detail for the new interior walls

Instructions:

- Answer this question on page 6.
- Draw, to scale 1 : 50 and to the given specifications, the following views of the proposed new **ladies and gents change rooms**:

4.1 The complete floor plan

4.2 The complete sectional south elevation on cutting plane A-A

- ALL drawings must comply with the guidelines contained in the SABS 0143.

SPECIFICATIONS:

THE FLOOR PLAN

Show the following features on the drawing:

- ALL the walls with hatching detail
- ALL the doors and windows
- The conventions of ALL the fixtures as indicated with the numbers
- ALL the electrical features as indicated with the numbers. Each change room's outside light and florescent tubes must be connected to the two-pole light switch.
- The cutting plane A-A

THE SECTIONAL SOUTH ELEVATION

Show the following features on the drawing:

- The complete foundation, floor, wall, window, ceiling and roof detail. The window must have two lintels.
- The doors and window to the north of cutting plane A-A
- The conventions of the fixtures to the north of cutting plane A-A
- ALL hatching detail

Label the following:

- The floor plan, including the scale
- The sectional south elevation
- The change rooms and floor finish (ceramic tiles)

NOTE:

ALL substructure hatching may be drawn in freehand





ASSESSMENT CRITERIA				
SECTIONAL SOUTH ELEVATION				
	POSSIBLE	OBTAINED	SIGN	MODERATE
1. WALLS + HATCHING	16			
2. WINDOWS + DOORS	10			
3. FIXTURES	5			
4. ROOF + CEILING	15			
5. LABELS	1			
SUBTOTAL	47			
FLOOR PLAN				
1. WALLS + HATCHING	12			
2. WINDOWS + DOORS	9			
3. FEATURES	11			
4. ELECTRIC	10			
5. LABELS	6			
6. CUTTING PLANE A-A	2			
SUBTOTAL	50			
TOTAL	97			

EXAMINATION NUMBER	
EXAMINATION NUMBER	6



DOOR AND WINDOW SCHEDULE

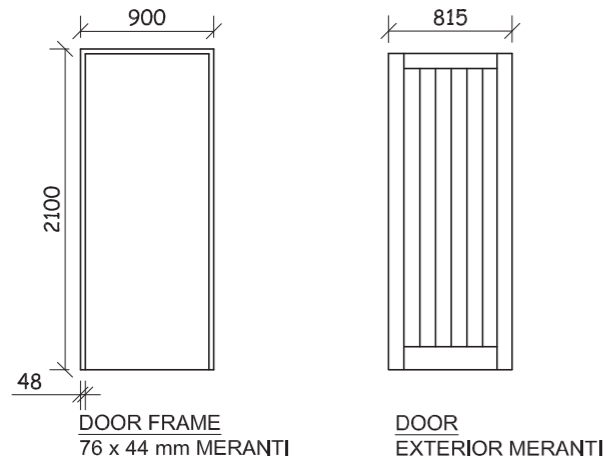
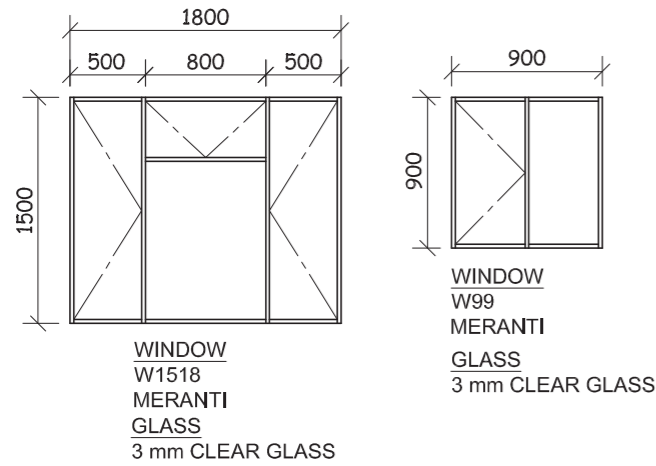

ELECTRICAL SYMBOLS

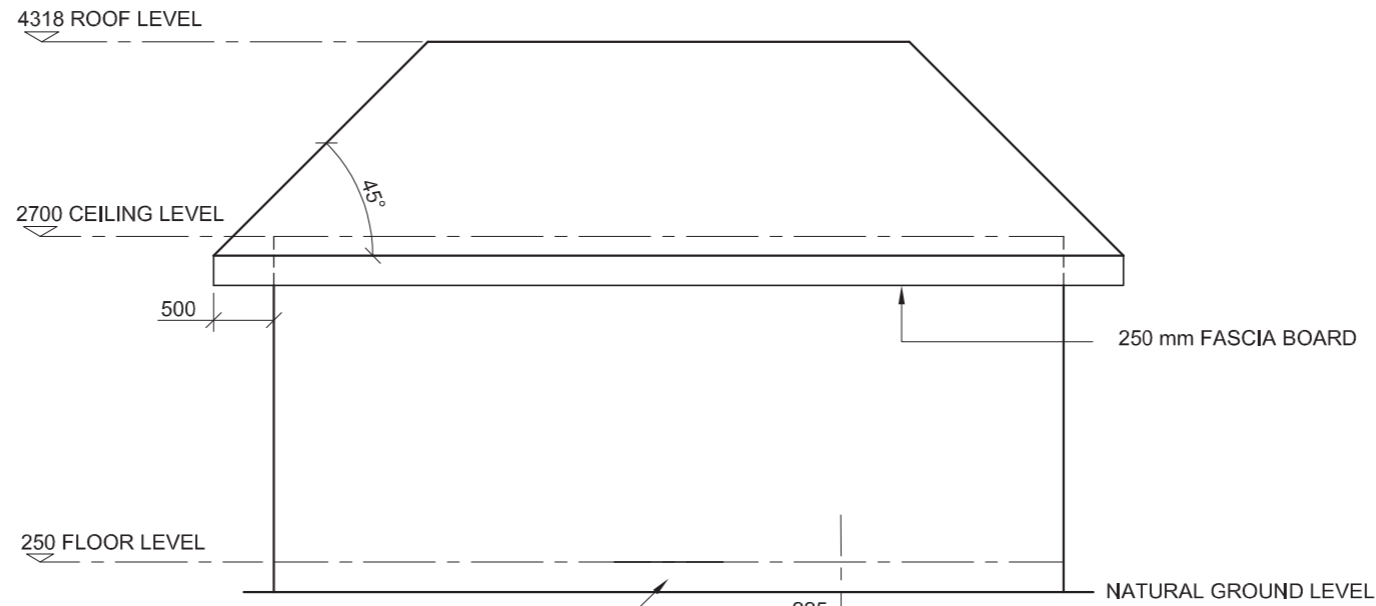
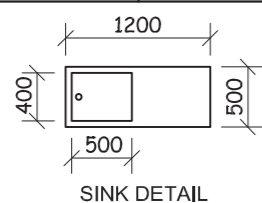
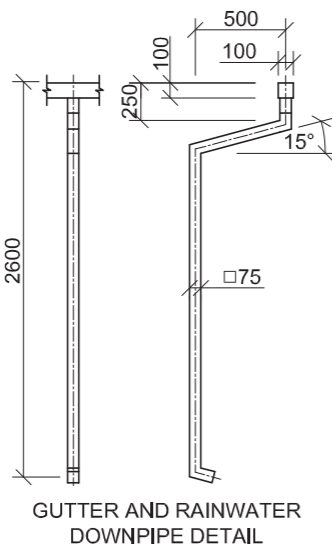
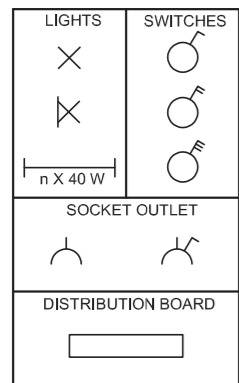

KEY TO NUMBERED FEATURES ON PLAN

1. DISTRIBUTION BOARD
2. SWITCH SOCKET OUTLET
3. LIGHTS
4. 2 x 40 W FLUORESCENT TUBES
5. OUTSIDE LIGHT
6. ONE-POLE LIGHT SWITCH
7. TWO-POLE LIGHT SWITCH
8. SINK
9. SHOWER
10. HANDBASIN
11. TOILET
12. RAINWATER DOWNPIPE

WEST ELEVATION

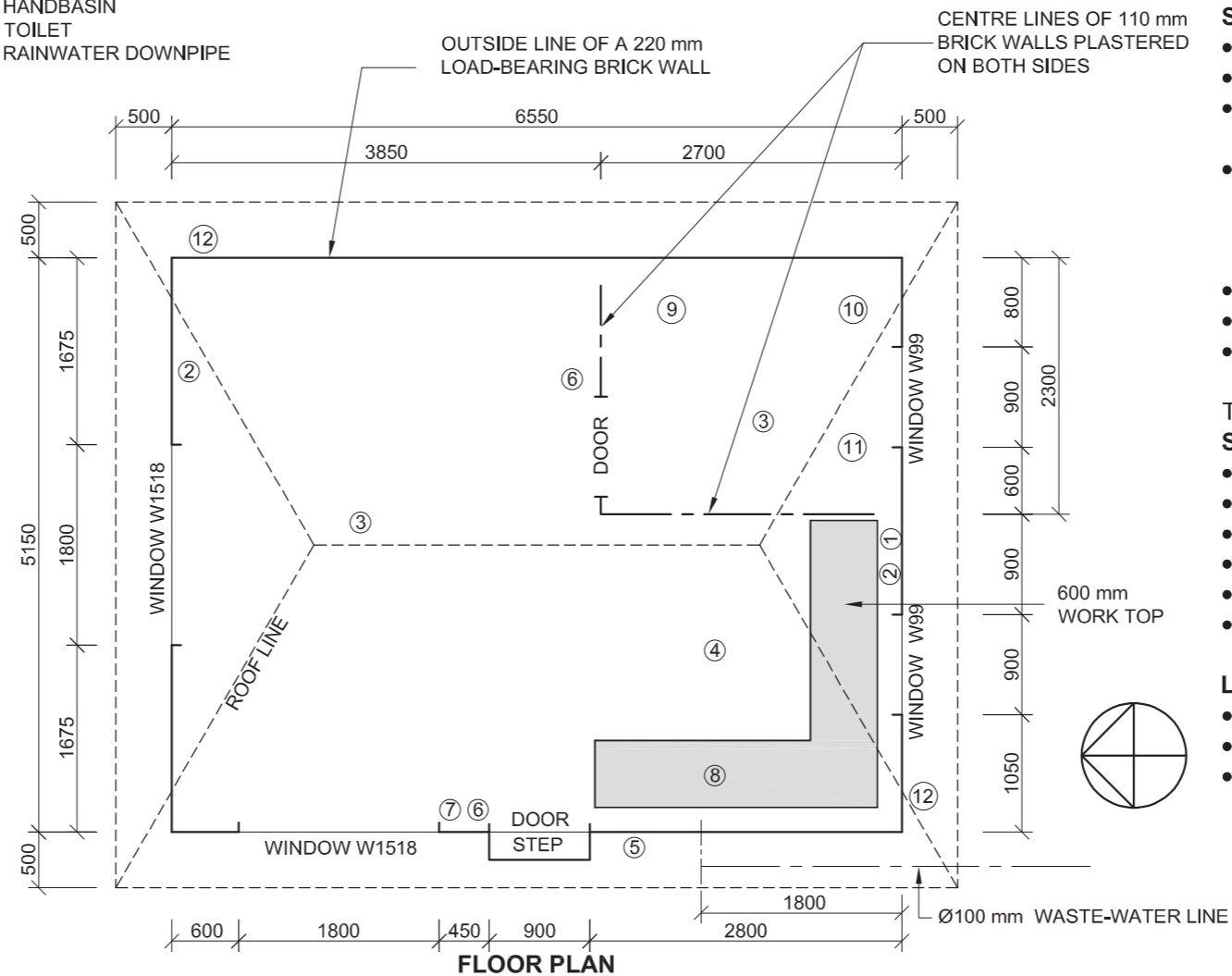

FLOOR PLAN

QUESTION 4: CIVIL DRAWING

Given:

- The incomplete west elevation of a new **granny flat** showing the outlines of the walls and roof, as well as the position of the kitchen's waste-water disposal system
- The incomplete floor plan of the new **granny flat** showing the outside lines of the exterior walls, the centre lines of the interior walls, the position of all the features, relevant notes and dimensions
- A door and window schedule
- A table of electrical symbols
- A detailed drawing of the gutter and the rainwater downpipe
- A detailed drawing of the sink

Instructions:

- Answer this question on page 6.
- Draw, to scale 1 : 50 and the given specifications:
 - 4.1 The complete floor plan
 - 4.2 The complete west elevation
- ALL drawings must comply with the guidelines contained in the *SABS 0143*.

SPECIFICATIONS:

THE FLOOR PLAN

Show the following features on the drawing:

- ALL the walls with hatching detail
- The doors, step and windows
- The conventions of ALL the bathroom fixtures as indicated with numbers on the incomplete floor plan
- ALL the electrical features as indicated with numbers on the incomplete floor plan. The light in the living area and the fluorescent tubes in the kitchen must be connected to the two-pole light switch.
- The work top and the sink detail
- The waste-water disposal system for the kitchen
- The roof line

THE WEST ELEVATION

Show the following features on the drawing:

- The outlines of the walls and roof
- The door, step and window
- The finished floor level
- The gutter
- Rainwater downpipes
- The waste-water disposal system for the kitchen

Label the following:

- The floor plan, including the scale
- The west elevation
- Using the correct abbreviations, label the following features on the correct view: finished floor level, sink, the fall of the waste-water line, inspection eye, bathroom designation and floor finish (ceramic tiles).



ASSESSMENT CRITERIA				
WEST ELEVATION				
	POSSIBLE	OBTAINED	SIGN	MODERATE
1. ROOF + FASCIA	5			
2. GUTTER + RWDP	6			
3. WALLS + FFL	3½			
4. WINDOWS + DOOR + STEP	13½			
5. WASTE-WATER	2			
6. LABELS	4			
SUBTOTAL	34			
FLOOR PLAN				
1. ROOF	4½			
2. WALLS	6½			
3. WINDOW + DOOR + STEP	16			
4. KITCHEN + BATHROOM	11½			
5. ELECTRIC	12			
6. WASTE-WATER	2			
7. HATCHING	4½			
8. LABELS	6			
SUBTOTAL	63			
TOTAL	97			

EXAMINATION NUMBER	
EXAMINATION NUMBER	6



DOOR AND WINDOW SCHEDULE

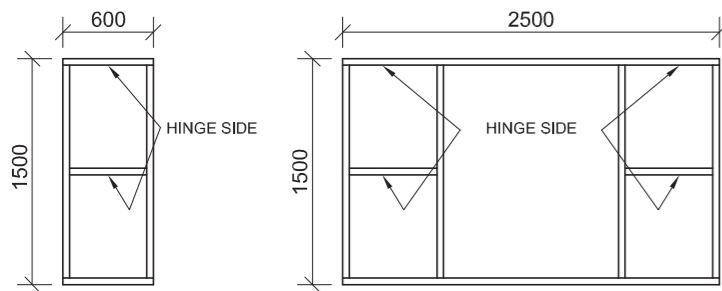

WINDOW
SG1
MERANTI

WINDOW
SH4
MERANTI

GLASS
3 mm CLEAR GLASS

GLASS
3 mm CLEAR GLASS

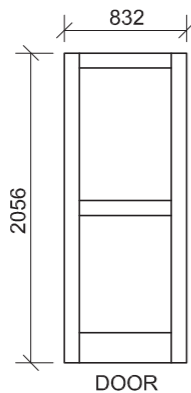
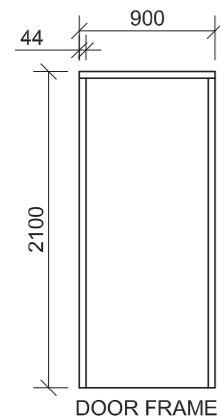

DOOR FRAME
230 x 44 mm MERANTI
DOOR FRAME

DOOR
EXTERIOR
MERANTI DOOR

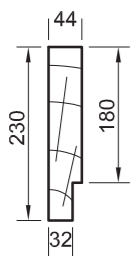

FRAME
PROFILE

ELECTRICAL SYMBOLS

LIGHTS	SWITCHES	SOCKET OUTLETS
⊗	○	⌋
⊗	○	⌋
⊗	○	⌋
⊗	○	⌋
⊗	○	⌋

ROOF NOTES:
ROOF COVER:
15 mm RCP ON 75 x 50 mm
PURLINS @ 1 300 C/C

114 x 38 mm GANG-NAILED
ROOF TRUSS ON A
114 x 38 mm WALL PLATE

228 x 38 mm FASCIA BOARD

6 mm CEILING BOARD
ON 38 x 38 mm BATTENS
@ 1 200 mm C/C

ROOF PITCH 20°

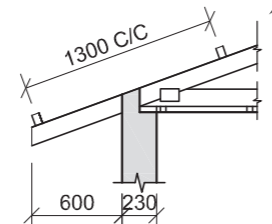

INCOMPLETE ROOF AND
WALL DETAIL

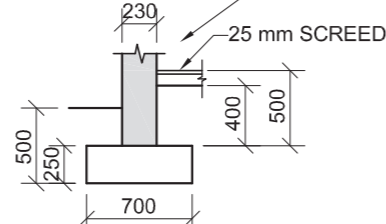

INCOMPLETE FOUNDATION
AND WALL DETAIL

EXTERIOR FEATURES
230 mm LOAD-BEARING WALL
DOOR OPENING
WINDOW OPENINGS

ELECTRICAL FEATURES
1. SWITCHED SOCKET OUTLET
2. 2 x 40 W FLUORESCENT TUBES
3. OUTSIDE LIGHT
4. TWO-POLE LIGHT SWITCH
5. SINGLE-POLE LIGHT SWITCH

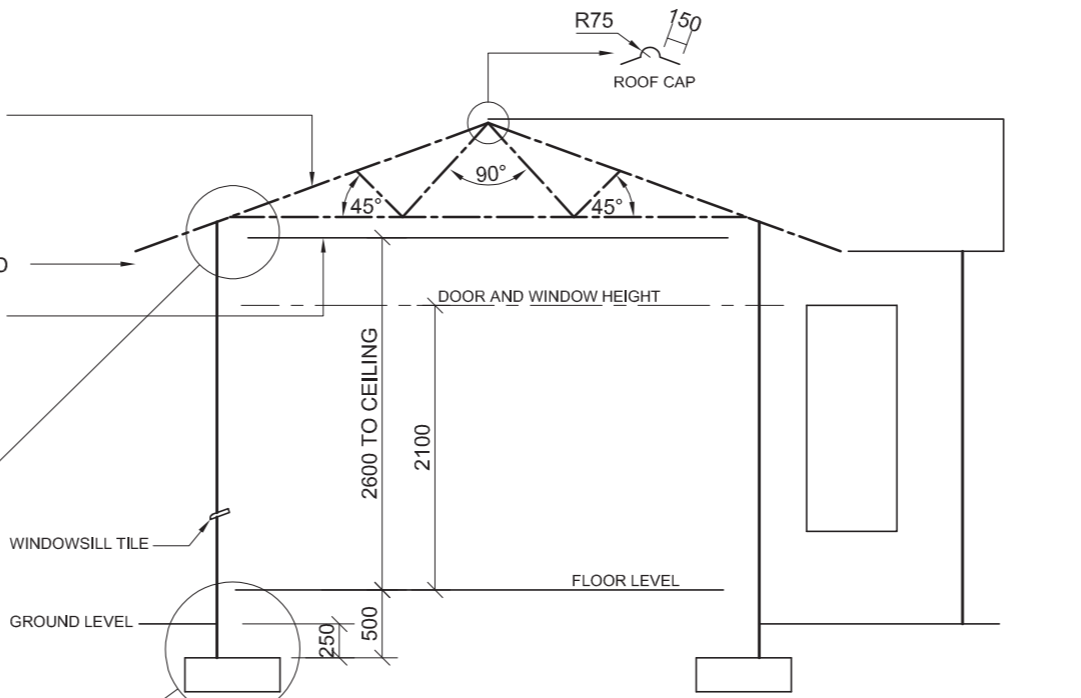

INCOMPLETE SECTIONAL WEST
ELEVATION

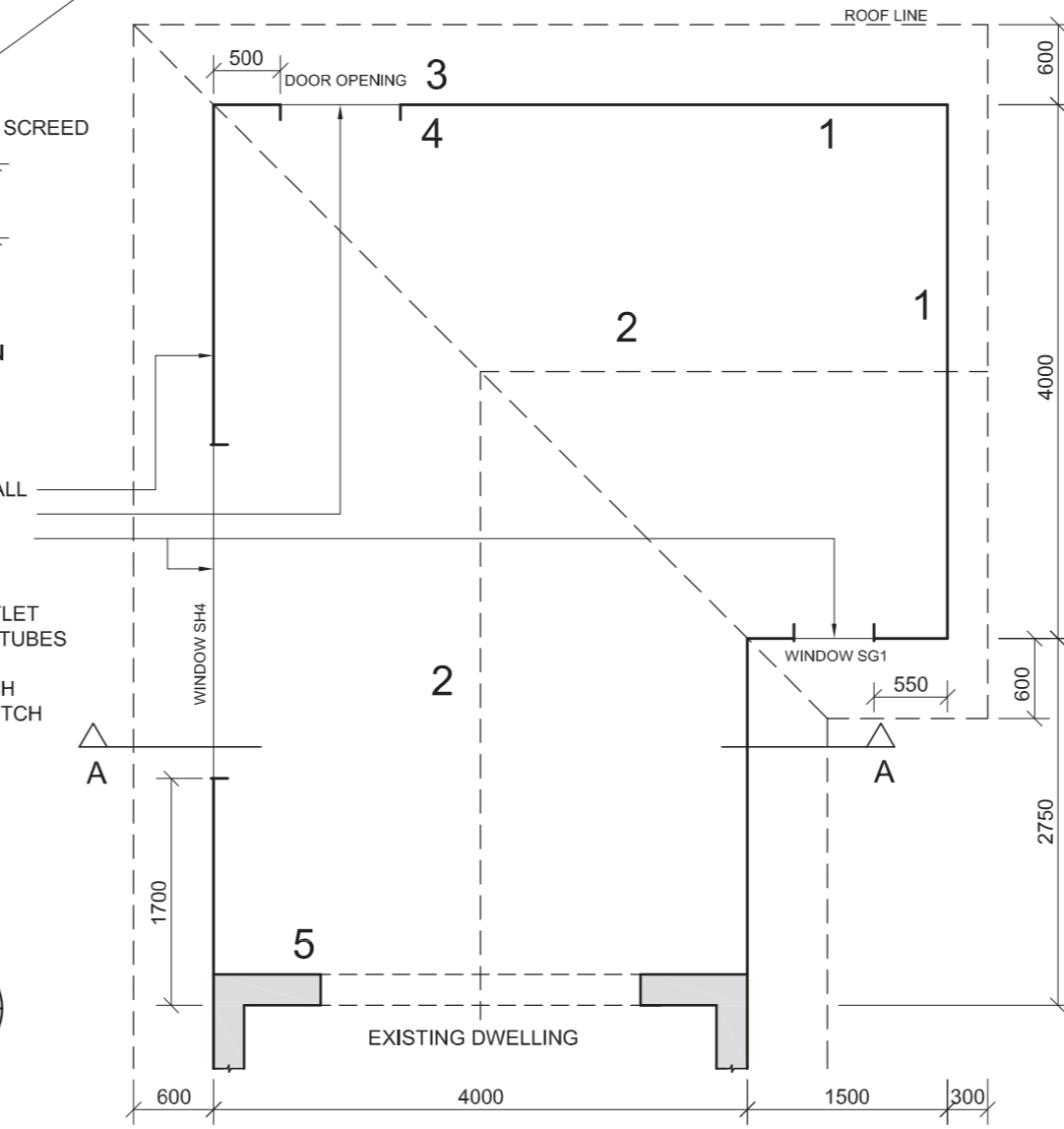

INCOMPLETE FLOOR PLAN

QUESTION 4: CIVIL DRAWING

Given:

- The incomplete sectional west elevation on cutting plane A-A of a new **family room** showing the outline of the walls and a schematic drawing of the roof truss
- The incomplete floor plan of the new **family room** showing the outline of the walls and the positions of all the features, notes and dimensions
- A door and window schedule
- A table of electrical symbols
- The incomplete roof and wall detail
- The incomplete foundation and wall detail
- The complete north elevation of the new **family room**, drawn to scale, on page 6

Instructions:

- Answer this question on page 6.
- Using the given north elevation as a guide, draw, to scale 1:50 and according to the given specifications:
 - 4.1 The complete floor plan
 - 4.2 The complete sectional west elevation on cutting plane A-A
- ALL drawings must comply with the guidelines contained in the SABS 0143.

SPECIFICATIONS:

THE FLOOR PLAN

Show the following features on the drawing:

- ALL the walls with hatching detail
- The door and windows
- ALL the electrical features as indicated with numbers on the incomplete floor plan
- The roof line
- The cutting plane A-A

THE SECTIONAL WEST ELEVATION

Show the following features on the drawing:

- The complete foundation, wall, slab and roof truss detail
- The door and window detail
- ALL hatching detail
- ALL other detail of the family room as seen from the west

Label the following:

- The floor plan, including the scale
- The sectional elevation
- Using the correct abbreviations, label the following features on the correct view: natural ground level, damp-proof course, room designation (family room) and floor finish (ceramic tile)

NOTE:

ALL substructure hatching may be drawn in freehand. [97]



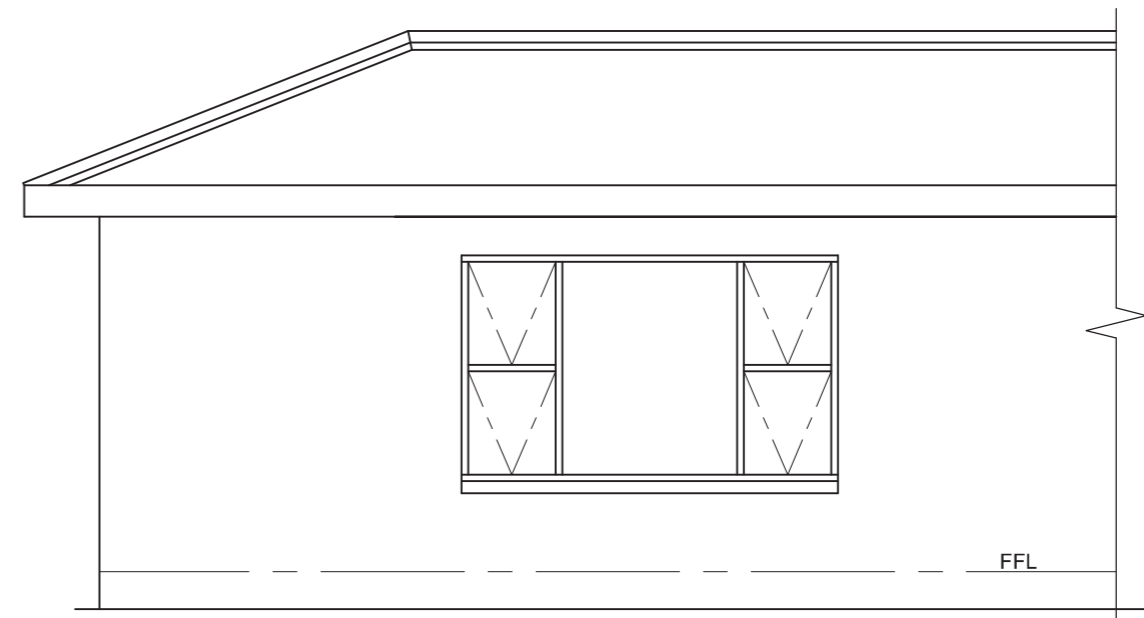





NORTH ELEVATION



ASSESSMENT CRITERIA					
SECTIONAL WEST ELEVATION					
		POSSIBLE	OBTAINED	SIGN	MODERATE
1	ROOF + CEILING	24½			
2	WINDOW + DOOR	14			
4	WALLS + FLOOR + FOUNDATION	11½			
5	HATCHING	5½			
6	LABELS	3½			
SUBTOTAL		59			
FLOOR PLAN					
1	ROOF	4			
2	WINDOWS + DOOR	7			
3	WALLS	9			
4	ELECTRICAL	8½			
5	HATCHING	3½			
6	LABELS + A-A	6			
SUBTOTAL		38			
TOTAL		97			
EXAMINATION NUMBER					
EXAMINATION NUMBER					
6					

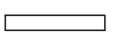

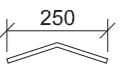
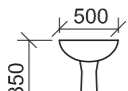
SCHEDULE OF COMPONENTS

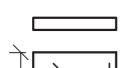
ROOF COMPONENTS	
	75 x 50 PURLINS
	200 x 18 FASCIA BOARD
	115 x 38 WALL PLATE
	ROOF CAP
FIXTURES	
	a - WASH BASIN
	b - WC
	c - SHOWER

DOOR SCHEDULE

DOOR
1 x STANDARD-SIZED DOOR

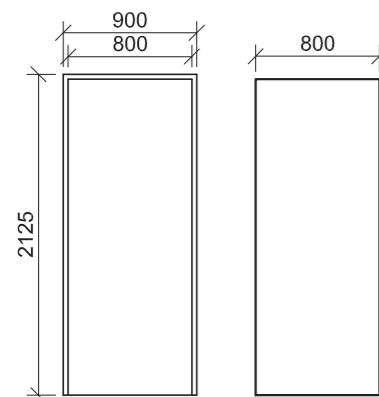

STEEL DOOR FRAME SECTION

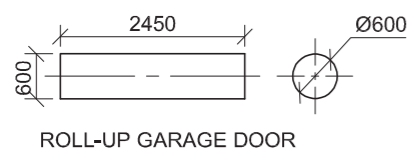

ROLL-UP GARAGE DOOR

WINDOW SCHEDULE

WINDOW
1 x STANDARD D1-SIZED STEEL FRAME

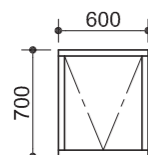









LIST OF FEATURES

- 200 mm LOAD-BEARING WALL
- 100 mm INTERNAL WALL WITH A 400 x 200 mm BRICK PILLAR
- WINDOW OPENING
- DOOR OPENING
- 100 x 1800 mm HIGH SHOWER WALL
- GARAGE DOOR OPENING
- FIXTURES**
 - a. WASH BASIN
 - b. TOILET
 - c. SHOWER

ELECTRICAL FEATURES

1. WALL-MOUNTED LIGHT
2. 2 x 40 W FLUORESCENT TUBES
3. CEILING LIGHT
4. DOUBLE-POLE LIGHT SWITCH
5. SWITCH SOCKET OUTLET

ELECTRICAL SYMBOLS

LIGHTS	SWITCHES
	
	
	
SOCKET OUTLETS	
	

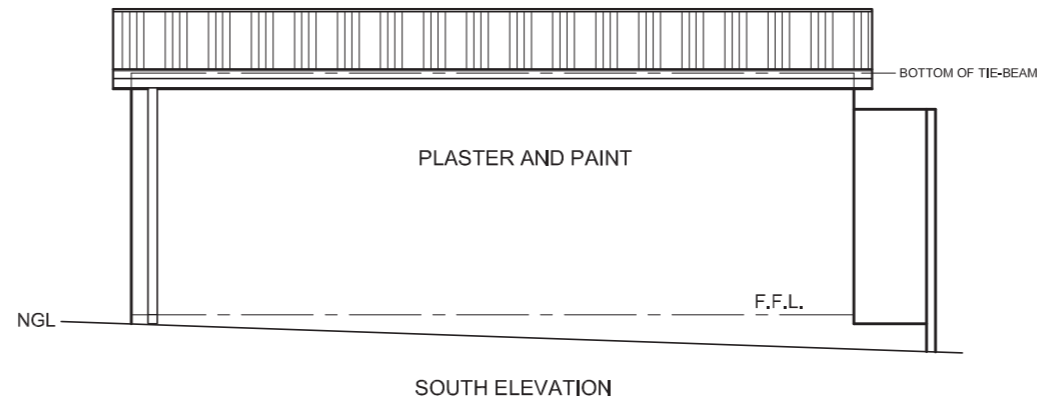

SOUTH ELEVATION

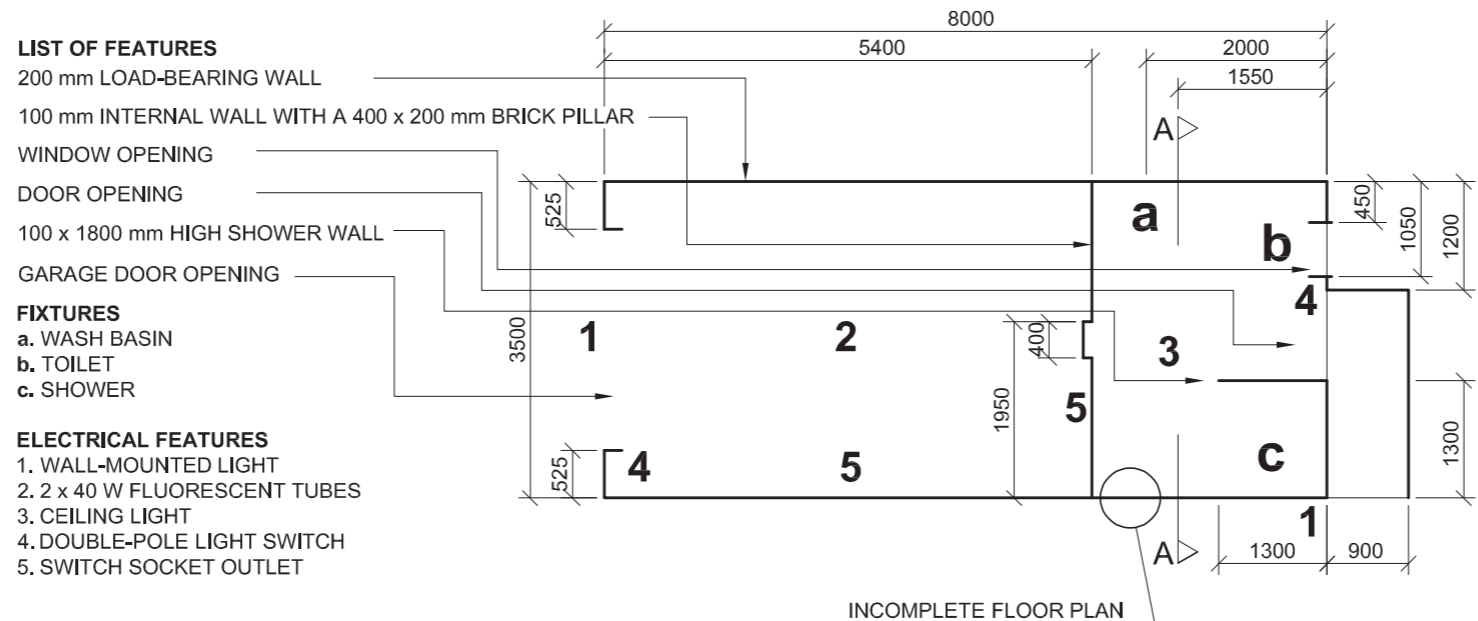

INCOMPLETE FLOOR PLAN

ROOF NOTE

37 x 740 IBR SHEETS LAID ON 75 x 50 PURLINS @ 1100 C/C ON 115 x 38 ROOF TRUSSES WITH 100 x 100 BOX GUTTERS ON 200 x 18 FASCIA BOARDS

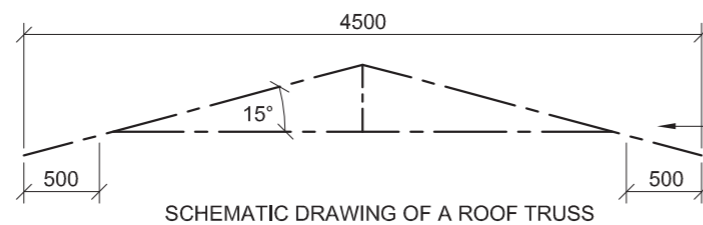

SCHMATIC DRAWING OF A ROOF TRUSS

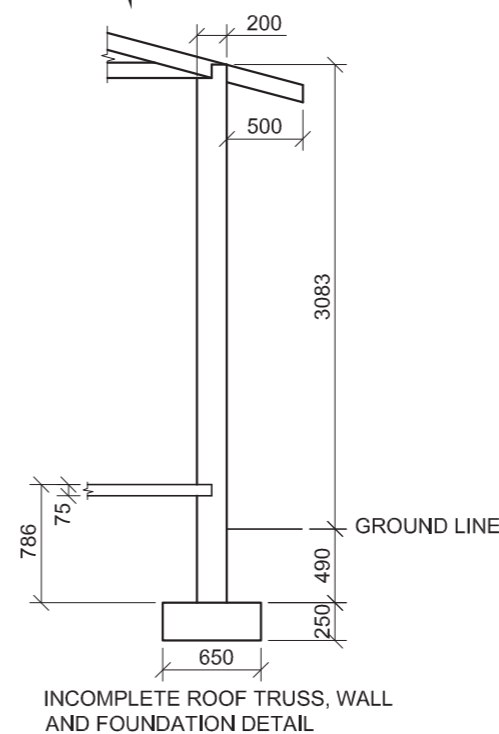

INCOMPLETE ROOF TRUSS, WALL AND FOUNDATION DETAIL

QUESTION 4: CIVIL DRAWING

Given:

- The complete south elevation of a proposed **free-standing garage with a bathroom** showing the walls and the visible features
- An incomplete floor plan of the proposed **free-standing garage with a bathroom** showing the outline of the walls, the positions of all the features with notes and dimensions
- A schedule of the components
- A table with electrical symbols
- A schematic drawing of a roof truss
- The incomplete roof truss, wall and foundation detail
- The complete south elevation of the proposed new garage with bathroom, drawn to scale, on page 6

Instructions:

- Answer this question on page 6
- Using the given south elevation as a guide, draw, to scale 1:50 and according to the given specifications:
 - 4.1 The complete floor plan
 - 4.2 The complete sectional elevation on cutting plane A-A
- ALL drawings must comply with the guidelines contained in the SABS 0143.

SPECIFICATIONS:

THE FLOOR PLAN

Show the following features on the drawing:

- ALL the walls with hatching detail
- The bathroom door, garage door and the window
- ALL the electrical features as indicated with numbers on the incomplete floor plan
- ALL the sanitary fixtures as indicated with letters on the incomplete floor plan
- The cutting plane A-A

THE SECTIONAL ELEVATION

Show the following features on the drawing:

- The complete foundation, wall, slab and roof truss detail
- The door and window detail
- The WC and shower detail
- ALL hatching detail

Label the following:

- The floor plan including the scale
- The sectional elevation
- Using the correct abbreviations, label the following features on the correct view: natural ground level, damp-proof course, room designations (garage and bathroom) and floor finishes (grano in the garage and ceramic tiles in the bathroom)

NOTE:

ALL substructure hatching may be drawn in freehand. [90]

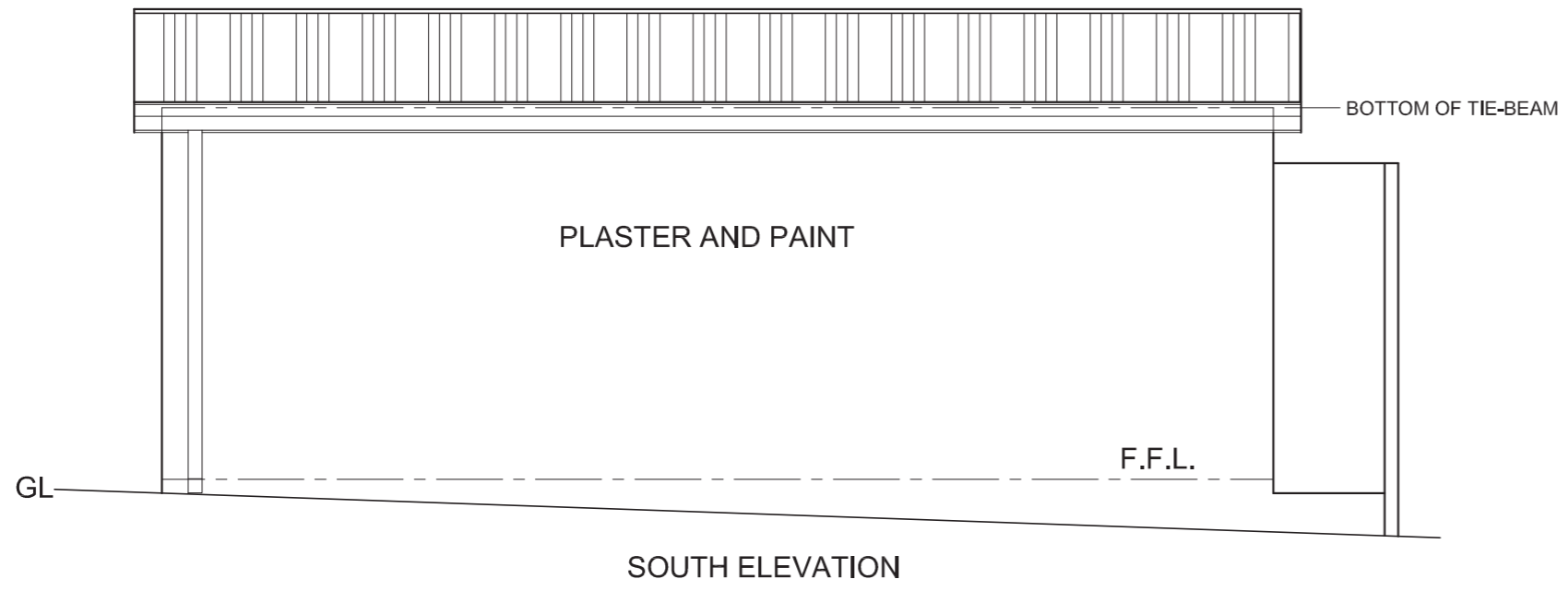

ASSESSMENT CRITERIA				
PLAN				
	POSSIBLE	OBTAINED	SIGN	MODERATE
1 CORRECT SCALE	1			
2 WALLS + HATCHING	17½			
3 WINDOW + DOORS	7			
4 FIXTURES	5			
5 ELECTRICAL	10			
6 LABELS + C'PLANE	5			
SECTIONAL ELEVATION				
1 CORRECT SCALE	1			
2 WALLS + FOUNDATION + HATCHING	19			
3 WINDOW + DOORS	8			
4 FIXTURES	3			
5 ROOF	10½			
6 LABELS	3			
TOTAL	90			
EXAMINATION NUMBER				
EXAMINATION NUMBER				6

FEATURE SCHEDULE

DOOR FRAME
STANDARD, EXTERNAL,
MILD STEEL

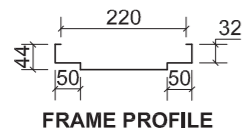

FRAME PROFILE

DOOR
H/W FRAMED, LEDGED
AND BATTENED

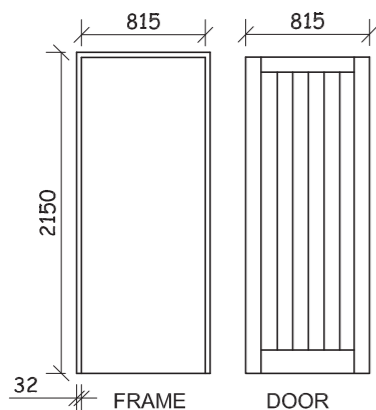

WINDOW
STANDARD C2 TIMBER
FRAME

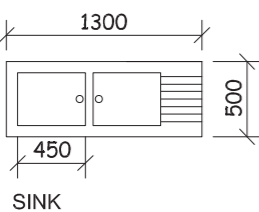
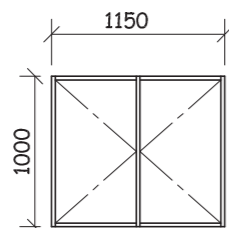

SINK

ELECTRICAL LEGEND

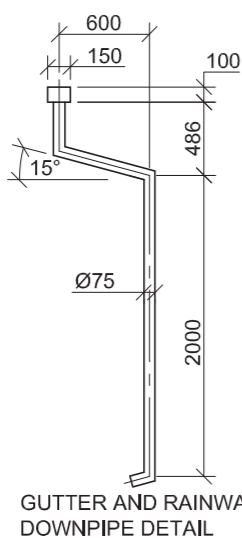
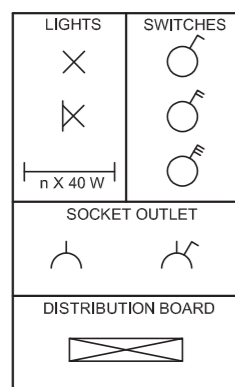

GUTTER AND RAINWATER
DOWNPIPE DETAIL

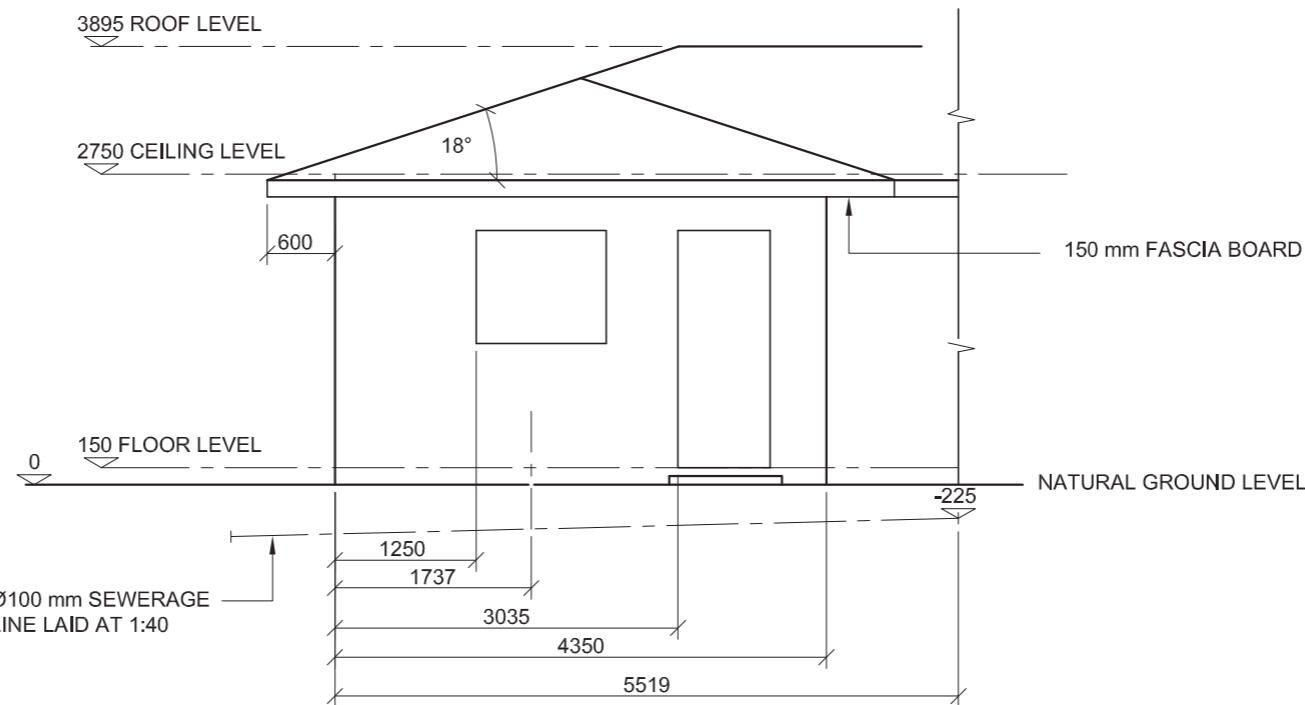

KEY TO NUMBERED FEATURES

1. DISTRIBUTION BOARD
2. SWITCHED SOCKET OUTLET
3. FLOURESCENT LIGHT FITTING (3 x 40 W TUBES)
4. OUTSIDE LIGHT FITTINGS
5. LIGHT SWITCH
6. SINK
7. RAINWATER DOWNPIPE

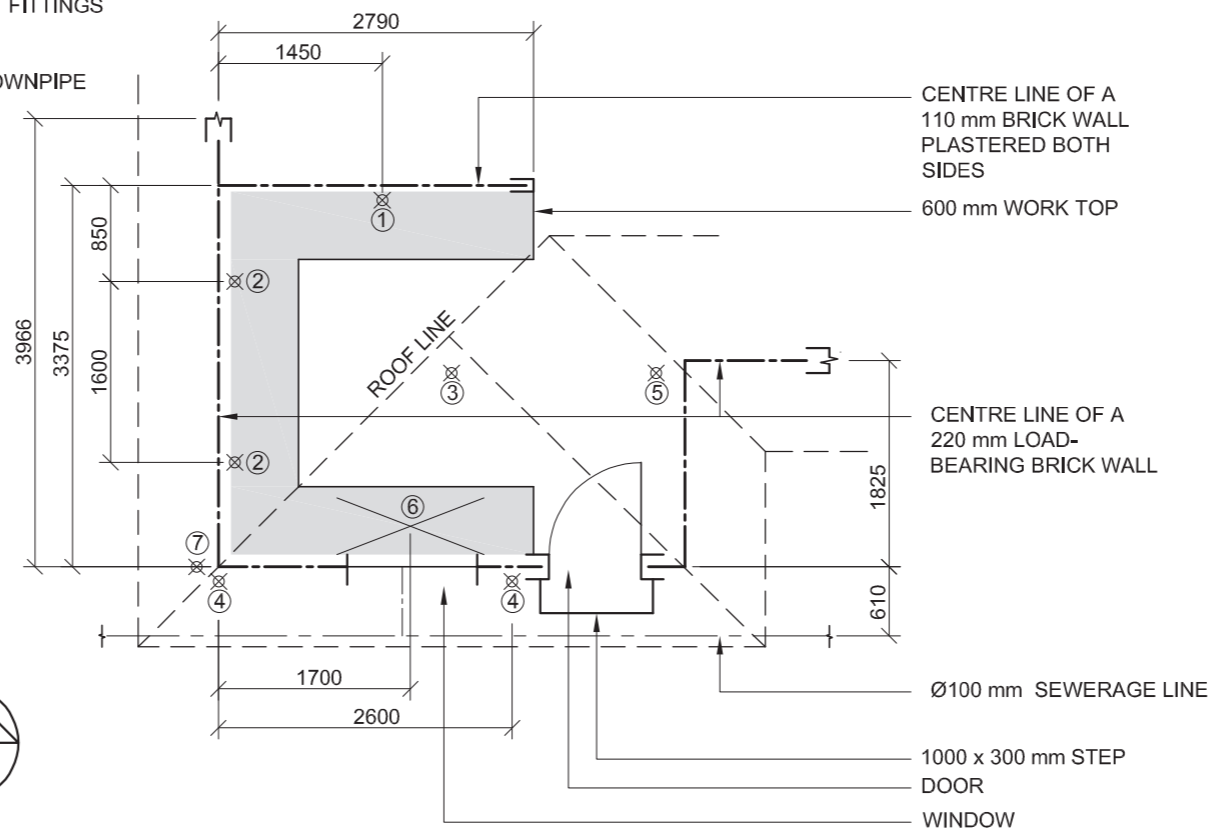

QUESTION 4: CIVIL DRAWING

Given:

- A schematic floor plan of a **kitchen** showing the centre lines of the walls with dimensions, the positions of all the features and notes.
- The incomplete south elevation of the **kitchen** showing the outside lines of the walls and the positions of some of the features.
- A schedule of features.
- A detailed drawing of the sink.
- A detailed drawing of the gutter and rainwater downpipe.
- A legend of electrical symbols.

Instructions:

- Answer this question on ANSWER SHEET 4 on page 6.
- Draw to scale 1:50 the complete floor plan and complete southern elevation of the kitchen to the given specifications.
- ALL drawing must comply with the guidelines contained in the SABS 0143.

SPECIFICATIONS:

THE FLOOR PLAN

Add the following features as indicated:

- ALL the walls with hatching detail
- The step
- The door and the window detail
- The distribution board
- ALL lights connected to ONE two pole light switch
- TWO outside lights and ONE flourescent light
- TWO switched socket outlets
- The work surfaces and the sink
- The waste-water disposal system (sewerage)
- The roof line

THE SOUTH ELEVATION

Add the following features as indicated:

- The complete wall and roof detail
- The step 75 mm high
- The door and complete window detail
- The gutter
- Rainwater downpipe detail on the west side of the building ONLY
- The waste-water disposal system (sewerage)

Label the following:

- The floor plan and include the scale
- The elevation
- Using the correct abbreviations, label the following features on the correct view: natural ground level, finished floor level, rainwater downpipe (RWDP), sink, waste-water disposal system, inspection eye, room designation and floor finish (ceramic tiles). **[97]**





ANSWER SHEET 4

ASSESSMENT CRITERIA

ELEVATION	POSSIBLE	OBTAINED
1 ROOF	4	
2 GUTTER / FACIA	7½	
3 WINDOW / DOOR	11	
4 WALLS / FFL / STEP	8½	
5 WASTE PIPES	3	
6 LABELS	6	
PLAN	POSSIBLE	OBTAINED
1 ROOF	4	
2 ELECTRICAL	9	
3 WINDOW / DOOR	7½	
4 WALLS / STEP	14	
5 WASTE PIPES / RWDP	5	
6 SINK / WORK AREA	6	
HATCHING	5½	
LABELS	6	
TOTAL	97	

EXAMINATION NUMBER

EXAMINATION NUMBER

6





DOOR AND WINDOW SCHEDULE		
PROPOSED NEW TV ROOM ON ERF 329 EAST LONDON	DRAWING NUMBER DOE 2-08	DOOR DEN 7 SIDE ROAD EAST LONDON 043 708 5555

DOOR FRAME
STANDARD, EXTERNAL,
MILD STEEL

WINDOW
STANDARD, MILD STEEL,
ND 511

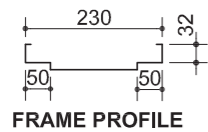

GLAZING
3 mm CLEAR GLASS

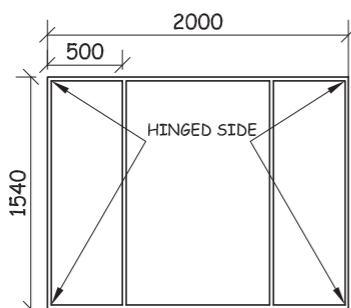

DOOR
H/W FRAMED, LEDGED
AND BATTENED

IRONMONGERY
1 PAIR 75 mm BOLTS and
HINGES
TWO-LEVER LOCKSET

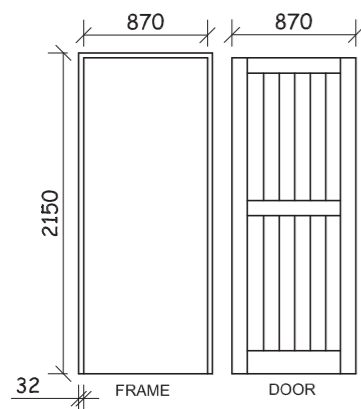

ELECTRICAL LEGEND

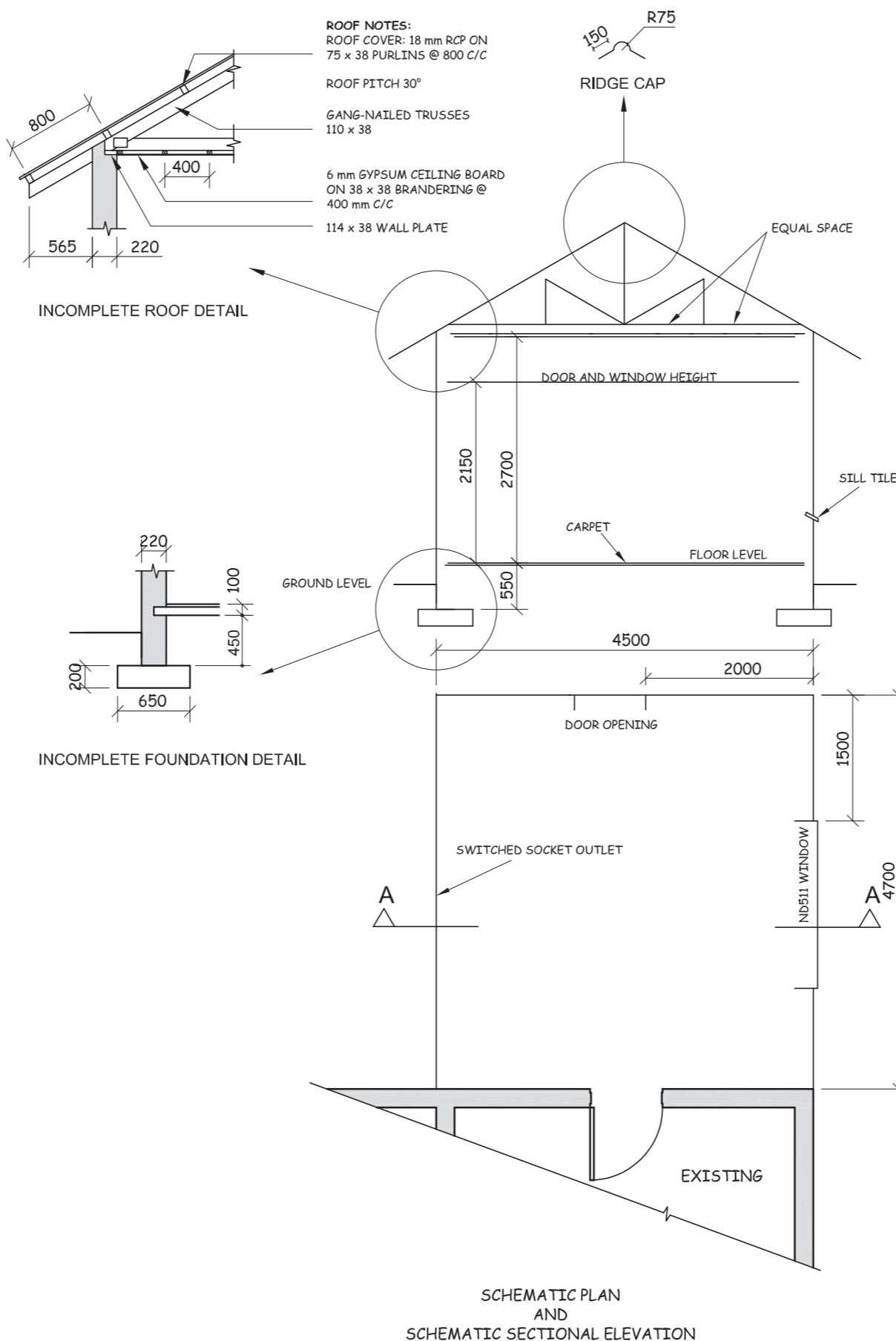
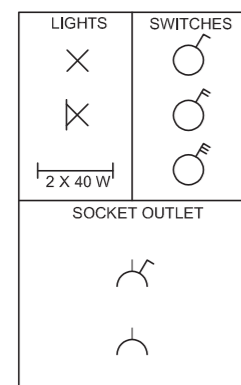

QUESTION 4: CIVIL DRAWING

Given:

- A schematic floor plan and schematic sectional elevation of the outer perimeter of a **proposed new TV room** to an existing dwelling, and the position of all the features.
- A door and incomplete window schedule.
- Sketches of the roof and incomplete foundation detail.
- An electrical legend.

Instructions:

- Answer this question on ANSWER SHEET 4 on page 6.
- Draw, to scale 1:50, the complete floor plan and complete sectional elevation to the given specifications.
- Attach the drawing of the **proposed new TV room** to the given information on ANSWER SHEET 4.

SPECIFICATIONS:

THE FLOOR PLAN

Add the following features to the floor plan:

- ALL the walls with hatching detail
- The door and the window detail
- ONE light outside the room and near to the door and ONE light in the centre of the ceiling of the **proposed new TV room**
- A separate switch for each light
- ONE switched socket outlet in the middle of the indicated wall
- The cutting plane. Label the plane A-A.
- Label the floor plan and include the scale

A SECTIONAL ELEVATION

Add the following features to the sectional elevation:

- The complete foundation, wall, floor slab and roof detail
- The door and complete window detail
- ALL necessary hatching
- Label the sectional elevation: SECTIONAL ELEVATION A-A

NOTE:

- Label **ONLY** the following features and on the correct view: natural ground level, damp proof course, proposed room designation and floor finish.
- ALL substructure hatching may be done in freehand.
- ALL drawing must comply with the guidelines contained in the SABS 0143. [97]

TERMINOLOGY

Schematic diagram: a diagram that shows the main features or relationships but not the details.



ANSWER SHEET 4

ASSESSMENT CRITERIA

	TOTAL	
	POSSIBLE	OBTAINED
FLOOR PLAN		
1 OUTLINE	5	
2 WINDOW & DOOR	7	
3 HATCHING	3	
4 LIGHTS & SWITCH & SOCKET OUTLET	8	
5 LABELS & CUTTING PLANE	8	
6 JOIN	1	
SECTIONAL ELEVATION		
7 FOUNDATION, SLAB & WALL	12	
8 HATCHING	9	
9 DOOR	3	
10 WINDOW	7	
11 ROOF TRUSS, CAP, GANGNAILS & COVER	17	
12 CEILING, PURLINS & BRANDING	12	
13 LABELS	5	
TOTAL 97		

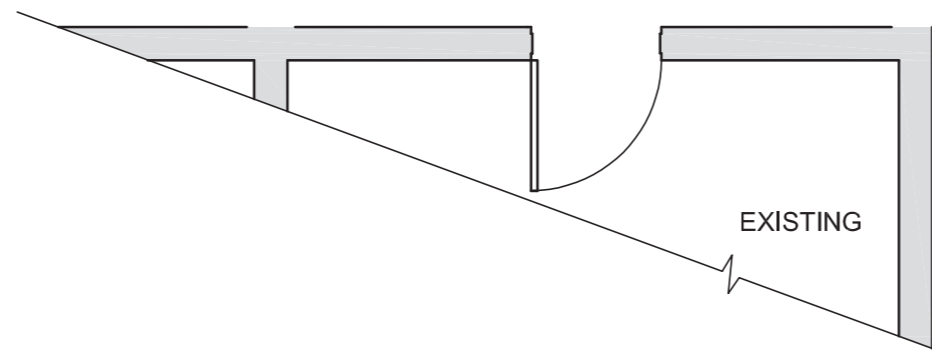

EXAMINATION NUMBER	
EXAMINATION NUMBER	6



DOOR SCHEDULE AND WINDOW SCHEDULE

PROPOSED NEW LAUNDRY ON STAND 354 PHOENIX MR K NAIDOO	DRAWING NUMBER DOE 1-08	D & W 7 ZIBI ROAD DURBAN 031 708 5555
---	-------------------------	--

DOOR FRAME
STANDARD, EXTERNAL, MILD STEEL

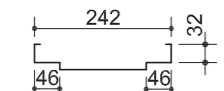

FRAME PROFILE

DOOR
H/W FRAMED, LEDGED AND BATTENED

IRONMONGERY
1 PAIR 75 mm BOLTS, HINGES
TWO-LEVER LOCKSET

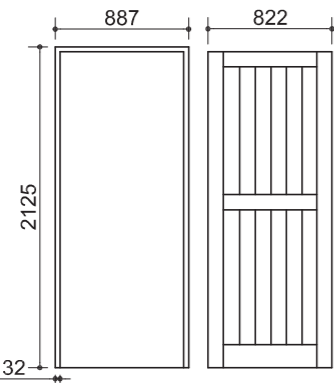

WINDOW
STANDARD, MILD STEEL, ND 2

GLAZING
3 mm CLEAR GLASS

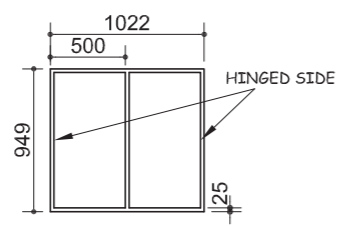

ELECTRICAL LEGEND

LIGHTS	SWITCHES
2 X 40 W	
SOCKET OUTLET	

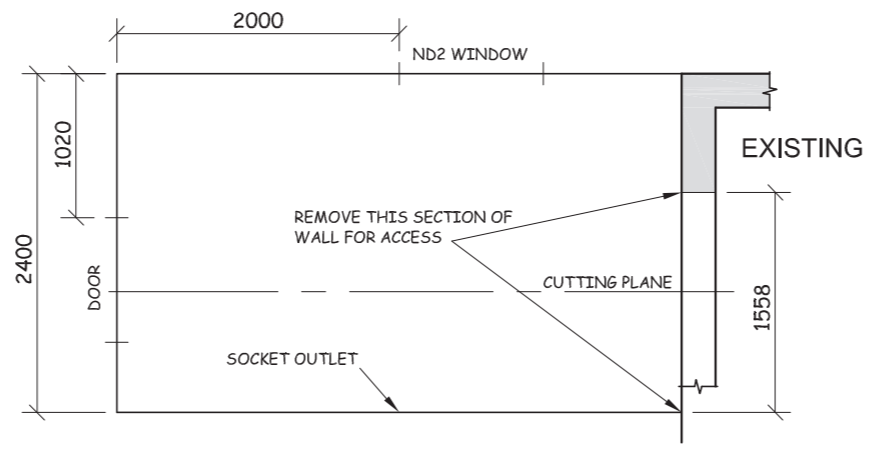
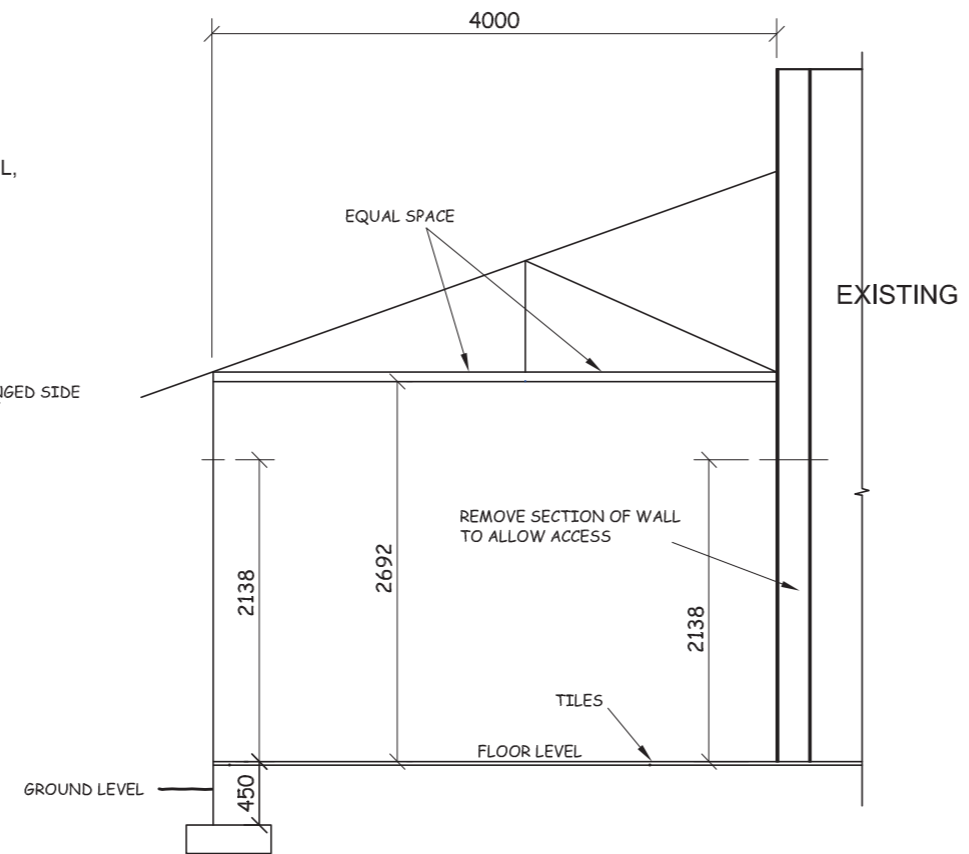

SCHEMATIC PLAN AND SCHEMATIC SECTIONAL ELEVATION

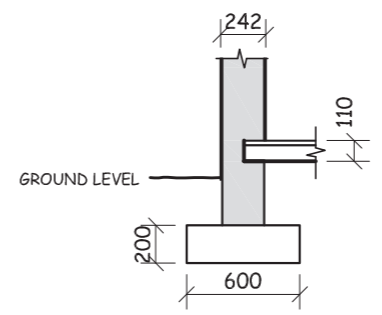

INCOMPLETE FOUNDATION DETAIL

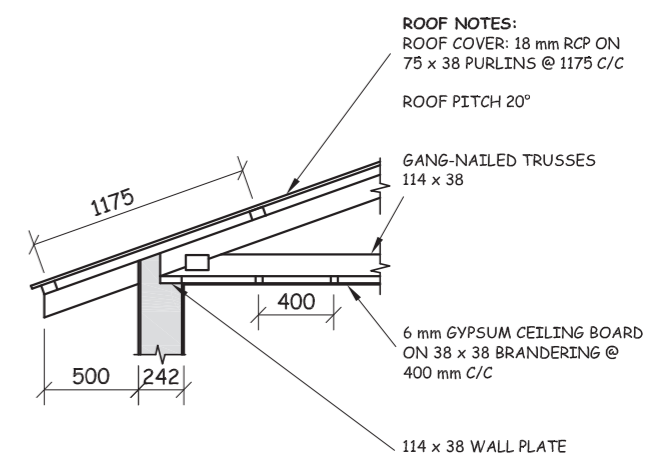

INCOMPLETE ROOF DETAIL

QUESTION 4: CIVIL DRAWING

Given:

- A schematic floor plan and schematic elevation showing the outer perimeter of a **proposed new laundry** to an existing dwelling detailing the positions of all the features.
- A door and incomplete window schedule.
- Sketches of the roof and incomplete foundation detail.
- An electrical legend.

Instructions:

- Answer this question on ANSWER SHEET 4 on page 5.
- Draw, to scale 1:40, the complete floor plan and complete sectional elevation to the given specifications.
- Attach the drawings of the **proposed new laundry** to the given information on ANSWER SHEET 4.

Specifications:

THE FLOOR PLAN

Add the following features to the floor plan:

- ALL the walls with hatching detail
- The door and the window detail
- The removed section of the wall of the existing dwelling
- ONE light outside the door and a single TWO, 40 watt fluorescent tube fitting in the centre of the ceiling of the laundry
- ONE switch for both lights
- ONE switched socket outlet in the middle of the indicated wall
- The cutting plane. Label the plane A-A
- Label the floor plan and include the scale

THE SECTIONAL ELEVATION

Add the following features to the sectional elevation:

- The complete foundation, wall, floor slab and roof detail
- The door and complete window detail
- The removed section of the wall of the existing dwelling
- ALL necessary hatching
- Label the sectional elevation: SECTIONAL ELEVATION ON A-A

Note:

- Label ONLY the following features on the correct view: natural ground level, damp proof course, window code, room designation and floor finish.
- ALL drawing must comply with the guidelines contained in the SABS 0143.

[95]



ANSWER SHEET 4

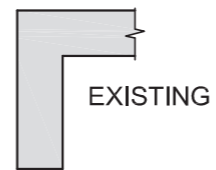
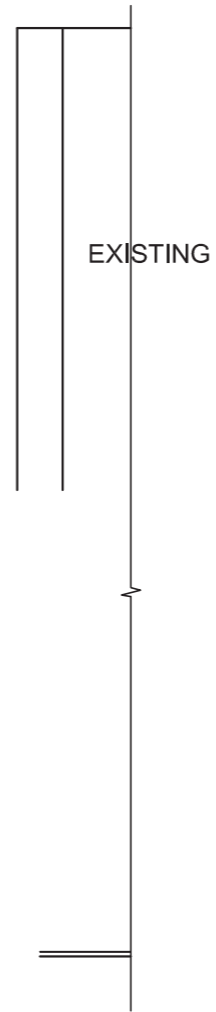

ASSESSMENT CRITERIA

	TOTAL	
	POSSIBLE	OBTAINED
FLOOR PLAN		
1 OUTLINE	9	
2 WINDOW & DOOR	9	
3 HATCHING	3	
4 LIGHTS & SWITCH & PLUG POINT	8	
5 LABELS AND CUTTING PLANE	9	
6 REMOVED WALL	2	
SECTIONAL ELEVATION		
7 FOUNDATION	2	
8 WALL & SLAB	8	
9 HATCHING	9	
10 DOOR & WINDOW	13	
11 ROOF & CEILING	17	
12 LABELS	3	
13 REMOVED WALL	3	
TOTAL 95		

EXAMINATION NUMBER	
EXAMINATION NUMBER	5