

Engineering Graphics & Design (EGD)

2023 **Grade 12**

GDE PAT Implementation Guidelines

for the 2022 Civil – and Mechanical Design Projects (PAT 1 & PAT 2)

Sarel de Bruin

Provincial Coordinator (DCES): Engineering Graphics & Design; 072 202 9483; sarelcdb@gmail.com & sarel.debruin@gauteng.gov.za

NOTE:

- **This 'Implementation Guideline' document is for EGD Teachers, DHs and Officials ONLY! It may therefore NOT be given to or shared with any learner!**
- The content of this document is aligned to the 'DBE EGD Grade 12 PAT 2023' document, and the additional '*Italic*' NOTES and 'inputs' in '**Dark Blue**' are for explanatory and/or clarification purposes only, and those in '**Dark Green**' are for new/changed content.
- The intent of this 'GDE Implementation Guidelines' document is merely to assist the EGD Teachers, DHs and Officials (EGD Subject Advisors) by highlighting the most important management, assessment and moderation requirements, as well as by providing clarity (for mediation purposes) on the scenario, presentation requirements and assessment criteria of the learners' 2023 PAT 1 and PAT 2 (Civil and Mechanical PATs), and not to replace the actual 'DBE EGD Grade 12 PAT 2023' document.

3. INSTRUCTIONS FOR THE ADMINISTRATION OF THE PAT

NOTE: These '*INSTRUCTIONS*' are for you, the EGD Teachers, DHs and Officials!

The teacher (*you*) must **provide a copy of and mediate** (including the revision of the *Design Process*) the entire **SECTION B (pages 9 to 28)** of the '*actual*' 2023 PAT document to **every (ALL your) Grade 12 learner** no later than **16 February 2023!**

GDE 2023 PRACTICAL ASSESSMENT TASK (PAT) MANAGEMENT PLANS

No	PAT activity	2023 Dates
GRADE 12		
1	Handing out of the entire SECTION B of the 2023 DBE Gr. 12 PAT document (i.e., pages 9 to 27) to each learner	16 Feb
2	Revision of the Design Process as well as explaining and discussing the two 2023 scenarios	16 & 17 Feb
3	PHASE 1 presentations and assessment completed	Before Wed 12 Apr
4	Moderation of PHASE 1	13 Apr – 23 May
5	PHASE 2 presentations and assessment completed	Before Tue 18 Jul
6	Moderation of PHASE 2	19 Jul – 04 Aug
7	PHASE 3 / ALL PAT presentations completed	By Fri 04 Aug
8	Final assessment of ALL PATs	05 – 09 Aug
9	ALL pre-moderated PAT marks submitted to EGD SES	10 & 11 Aug
10	Final provincial moderation of ALL 'complete PATs'	16 Aug – 28 Sept

NOTE: The date of '**By Friday 04 August 2023**' is **NOT NEGOTIABLE!**

Although the PHASES could be completed either **cyclically** or during **block times**, as indicated in the CAPS, it is recommended that **ONE ENTIRE day per term (e.g., from 08:00 to 16:00+)** be allocated to each PHASE (e.g. as an extra paper during the June examinations).

Teaching time allocated for the preparation and completion of all three PHASES of the PAT **may NOT exceed 16 hours**. However, **additional non-teaching time** may also be allocated for the completion of the PAT **at the school**, but the **TOTAL TIME (max)** allocated for the completion of **ALL the PHASES** of the PAT should **NOT exceed 20 hours**.

To ensure that the PAT is completed within the stipulated timeframes, it is **essential that the teacher (you) prepares and communicates (verbally) a management plan/pacesetter with target dates**. This will help learners monitor their own progress, and **for the teacher (you) to implement intervention programmes**.

NOTE:

To ensure the integrity of the PAT as a '**third NSC examination paper**', the following additional instructions **must be adhered to**. Non-compliance to any of these, and aforementioned instructions, will be deemed a **serious examination irregularity**.

- It is the **responsibility of the teacher (you)** to ensure that **each learner's PAT** is of an **appropriate Grade 12 level and complexity**.
- **ALL presentation requirements** of the selected PAT **must be strictly adhered to**.
- Except for the required research component, **ALL the presentation requirements** of the PAT **must be completed at school under the supervision of the teacher (you)**.
- **Explanatory examples**, e.g. graphical illustration, best practices from previous years' PATs, etc., **may ONLY be presented to the learners during the initial mediation of the PAT**. As the **explanatory examples may NOT be given to the learners or left for them to view 'indefinitely' after the initial mediation**, learners **must be encouraged to take notes during the initial mediation**, but **may NOT take any photographs or videos**.
- Although the sharing of knowledge and ideas between learners is permissible, **no presentation may be shared or copied as the entire PAT must be completed individually**. **ALL the presentations**, including the front page, table of contents (*index*), management plan, etc., **must be each learner's own original work**.
- Except for **clean A4 and A3 drawing sheets and grid/graph paper**, **NO templates**, pre-prepared pages/drawing sheets, redrawn examples of the site plan, etc., **may be provided to the learners in any form or format**.
- **NO examples of possible or suggested solutions of any component of the PAT may be provided to, or procured for, the learners in any form or format**. This includes, but is not limited to, examples developed by any individual, group, department, institution, organisation or business.
- **ALL learners must be encouraged to work on their own**, with **minimal intervention**. Developmental feedback and guidance **may ONLY be given** on presentations or a PHASE that **has already been attempted/prepared/completed**, or when the learner requests it.

NOTE: A learner must i.e. first attempt/do a presentation requirement before you do 'assessment for learning', i.e., before you give feedback and guidance!

NOTE: The following regarding CAD drawings is new in the 2023 EGD PAT Guidelines!

- When learners prepare drawings in CAD, the **following must be adhered to**:
 - The **school must provide the facilities**, including the CAD program(s) and computers. The **school must hold the licenses** of ALL the CAD programs used by the learners, and **NO other programs may be used** by any of the learners.
 - **ALL CAD drawings must be prepared at school under the supervision of the teacher (you)**.
 - The **opportunity to be trained using a CAD program must be made available to ALL learners**, regardless of whether they use it or not.

- As the **teacher (you) remains responsible for assessing** both the competence displayed in using a CAD program and the layout and correctness of the drawing presentations, he/she (you) must have **sufficient knowledge of and skills in the CAD programs used.**
- **Electronic and hard copy evidence** of the **history** of the **stage-by-stage development** of each learner's CAD drawings **must be retained at the school** for a period of time as stipulated by the Department of Basic Education (DBE).
- During the moderation process learners may be called upon to explain the functions and principles of operating the CAD program(s) *uses*, and to demonstrate drawing skills through performing capability tasks.
- The **DECLARATIONS OF AUTHENTICITY**, as set out on page 28 of the '*actual 2023*' PAT document (*p. 34 of this doc.*), **must be completed and signed by learner and the teacher 'only' prior to the final assessment.**
- The **SUMMATIVE ASSESSMENT SHEET**, as set out on page 27 of the '*actual 2023*' PAT document (*p. 33 of this doc.*), **must be completed in full for each learner following the final assessment of the PAT.**
- The **teacher must ensure** that **ONLY** the completed **SUMMATIVE ASSESSMENT SHEET, DECLARATION OF AUTHENTICITY** and relevant **CHECKLIST** **are included** after the table of contents (*index*) in each learners completed PAT file/portfolios.

4. ASSESSMENT AND MODERATION OF THE PAT

4.1 Assessment

NOTE:

Inconsistent assessment (marking), as well as NOT applying the 'level descriptors', especially the final 'verification of marks' out of '10', correctly, was again found to be some of the major areas of concern during the 2022 Provincial Moderation of the PATs.

Assessment of the PAT must be done according to the included and relevant 2023 ASSESSMENT CRITERIA AND CHECKLIST.

Frequent developmental feedback is needed to determine and provide guidance and support to ALL the learners, as well as to ensure that they are on the right track ('assessment for learning'). Both formal and informal assessment must therefore be conducted throughout the development of the PAT. Informal assessment may be conducted by either a peer or by the teacher.

The **teacher (you) must conduct ALL formal assessment** and **record the results on the official mark sheets.** The marks of each learner **must also be indicated on the official SUMMATIVE ASSESSMENT SHEET** (see page 26 of PAT, *or p. 33 of this doc.*), which **must be included** in the learner's PAT file/portfolios.

NEW: Where a school has **more than one Grade 12 EGD teacher**, the **teachers must assist one another by conducting PAT assessment as a team.** This will ensure a consistent standard of assessment across all the learners.

The **final formal assessment** must be **completed before** commencement of final provincial moderation (*i.e., before 10 August 2023 for the ALL GDE schools*).

Once the PATs have been assessed and moderated, the **teacher/school (you) must retain ALL the PATs for external moderation.** ALL the PATs must also be retained at school for a period of time as stipulated by the Provincial Department of Education (*GDE*).

Clarification of level descriptors and the verification of marks:

- **1-mark level descriptor:**

NOTE: There is NO percentage (%) for the 1-mark level descriptor!

1-mark level descriptive	0	Requirement not met or presented incorrectly
	1	Requirement has been met and/or presented correctly

This level descriptor is used for **elementary/basic presentation requirements and/or drawing features**, and must be applied as follows:

- **'0' (zero) must be allocated** for the **requirement NOT met**, or if the **presentation thereof is INCORRECT**.
- **1 mark may only be allocated** if the **requirement has been met FULLY** and the **presentation thereof is CORRECT**.

- **2-mark level descriptor:**

2-mark level descriptive	0	Requirement not met, or less than 30% evidence of knowledge shown (very poor)
	1	Requirement included and at least 30%+ evidence of knowledge shown (avg.)
	2	Presentation shows at least 80% or more evidence of knowledge (very good)

- **'0' (zero) must be allocated** if the **requirement has NOT been included/shown**, or if the **presentation of the requirement shows less than 30% evidence of knowledge**, or when the requirement is **VERY POOR**.
- **1 mark must (may only) be allocated** if the presentation of the **requirement shows at least 30% or MORE evidence of knowledge**, or the requirement is **NOT complete** or **NOT completely correct**, **NOT compliant** and/or **clear**, i.e. **AVERAGE**.
- **2 marks may only be allocated** if the presentation of the **requirement shows at least 80% or MORE evidence of knowledge**, and the **requirement is more than 80% complete**, **correct/compliant** and **clear**, i.e. **VERY GOOD**.

- **7-mark level descriptor**

Refer to the 7-mark rubric on page 45 of the CAPS document for the level descriptors.

DESCRIPTION for MARK	GENERAL INDICATORS	± PERCENTAGE	MARK
OUTSTANDING	Error free	100%	7
MERITORIOUS (VERY GOOD)	Few errors	± 80% +	6
SUBSTANTIAL (GOOD)		± 70%	5
ADEQUATE (SATISFACTORY)	Some errors (± ½ right and ½ wrong)	± 55% Just MORE than a 50%	4
MODERATE (ACCEPTABLE)		± 40% Just LESS than a 50%	3
ELEMENTARY (UNACCEPTABLE)	Many errors	± 33%	2
NOT ACHIEVED (VERY BAD)	Completely wrong	± 25% & LESS	1
NON-/NO COMPLIANCE	No evidence	Nothing to mark	0

This implies that a **'7' can only be allocated** if the presentation **requirement(s)** is **100% CORRECT/COMPLIANT**, i.e. **outstanding** and **ERROR-FREE**.

- **Verification of ALL final marks out of 10:**

Each final mark out of 10 **MUST be verified** according to the descriptors contained in the rubric on page 26 of the PAT document (p. 32 of this doc.). This implies that a **'10' can only be allocated** if the **presentation requirement(s)** is **100% CORRECT/COMPLIANT**, i.e. **PERFECT** and **ERROR-FREE**.

- **Rounding-off of marks:**

Each mark out of 10 must be **rounded off before being captured** on the **SUMMATIVE ASSESSMENT SHEET** (see page 26 of the PAT document, *or 'p. 33 of this doc.'*) and the **recording/mark sheet**. **A mark of 9,5 (or even 9.75) must, however, remain a 9 as the 0,5 (or 0.75) is an indication of a mistake.** **The final mark out of 25, 50 and 25 for each of the three complete sections of the PAT must also be rounded off after being calculated.**

4.2 Moderation

Moderation of the PAT **must be conducted using the included relevant 2023 ASSESSMENT CRITERIA AND CHECKLISTS**, and according to the **same level descriptors** used for assessing the PATs.

As **monitoring and/or moderation of the PAT can take place at any stage during the development of the PAT**, **ALL completed presentation requirements of ALL the PATs must always be available at the school.**

To **facilitate intervention programmes and processes**, the following **school-based and cluster/district moderation must be done during Terms 2 and 3:**

- **Phase 1:** Design process (**'from'** beginning of Term 2 **'until 23 May 2023 for GDE'**, or before the commencement of PHASE 2, or at the latest before the **May/June Examinations for other PEDs**)
- **Phase 2:** Presentation drawings (**'from'** beginning of Term 3 **'until 04 Aug 2023 for GDS'**, or before the commencement of PHASE 3 **for other PEDs**)

For other PEDs, final provincial moderation must be concluded **before** the commencement of **DBE and/or Umalusi moderation**, or **at the latest** by the end of **Week 3 of Term 4**.

To **assist the moderator with the moderation process**, the teacher **must supply a complete set of updated mark sheets and merit lists.**

At the beginning of the moderation process the **moderator must select 10%**, with a **minimum of THREE** and a **maximum of SIX** PAT files/portfolios, **from ALL the of the school's PAT files/portfolios.**

The selected PATs must be:

- No. 1 – a high/highest mark; ▪ No. 2 – an avg./middle mark; ▪ No. 3 – a low mark;
- No. 4 – an avg./middle mark; ▪ No. 5 – a high mark; ▪ No. 6 – a low mark.

If the **selected PATs do not provide a consistent result**, **THREE additional PATs**, i.e. a **high-**, an **average/middle-** and a **low-mark PAT**, must be selected and moderated to **obtain more consistent results. Repeat until more consistent result is obtained!**

If **a school has more than ONE Grade 12 EGD teacher**, **THREE PATs**, i.e. a **high-**, an **average/middle-** and a **low-mark PAT**, **must be selected from EACH teacher.**

NOTE:

A tolerance range of ONLY 5% is permissible between the **average assessed mark** and the **average moderated mark** of the **PATs selected for moderation**. Only once moderation has been completed **must the more than 5% difference** between the average marks of the moderated PATs **be applied to the remainder of the PAT's.**

NOTE:

- **SECTION B of the 'actual' DBE EGD Grade 12 PAT 2023 document is the '2023 NSC PAT Question Paper' that every Grade 12 EGD learners is entitled to.**
Every Grade 12 EGD learner MUST therefore be provided with a copy of the entire SECTION B, i.e., pages 9 to 28, of 'actual' DBE EGD Grade 12 PAT 2023 document, and NOT of this 'Implementation Guideline' documents!
- **This 'GDE Implementation Guidelines' document focuses on both PAT 1 (Civil) and PAT 2 (Mechanical), as contained in the 'actual' DBE EGD Grade 12 PAT 2023 document.**

SECTION B (LEARNER TASKS)

General information and instructions:

- **The EGD PAT is a compulsory national formal assessment task** that contributes 100 marks (25%) towards your final National Senior Certificate (NSC) mark.
NOTE: If a learner does not complete an EGD PAT, he/she will not be resulted for EGD!
- This document contains the following **TWO PAT scenarios**:
 - **PAT 1:** A civil design task, with an **electrical** component
 - **PAT 2:** A **mechanical** design task

You, **the learner, with the guidance of your teacher**, must select and complete **ONE** of the PAT tasks contained in this **(2023)** document.
NOTE: As per the 5th bullet on page 18 of the 'actual' DBE EGD Grade 12 PAT 2023 document, you, the teachers, must still approve each learners' selected dispenser. This is to ensure that it meets the requirements and that a PAT of an appropriate higher-order Grade 12 complexity can be produced.
- **ALL** the **presentation requirements** of the selected PAT **must be strictly adhered to** and, with the exception of the research component, be **completed at school, under the supervision of your teacher**.
- Although the sharing of knowledge and ideas is permissible, **no presentations may be shared or copied**. The **entire PAT must be completed individually and ALL the presentations (each learner's presentations)**, including the front page, table of contents, management plan etc., **must be your own original work**.
- The PAT must be completed in phases and within the given time frames of your teacher's pacesetter/management plan.
- **ALL freehand drawings and instrument drawings must be prepared in pencil**.
- The PAT must be of an appropriate higher-order Grade 12 complexity.
- The PAT will be assessed according to the relevant **'2023' ASSESSMENT CRITERIA AND CHECKLISTS**, which are included in this **'2023' PAT** document.
- The **relevant ASSESSMENT CRITERIA AND CHECKLIST** for the PAT (i.e. either pages 16 and 17 or pages 23 and 24 *'of the actual PAT'*) **must be used to provide clear evidence of your own continuous self-evaluation** and the **meeting of the deadlines** during the development of the PAT. *(Either the 'individual CHECKLISTS' after each requirement or the 'combined CHECKLISTS' on pages 16 & 17 or 26 & 27 of this doc. may be used!)*
- **Just** prior to the final submission of your complete PAT, you must complete and sign the **DECLARATION OF AUTHENTICITY**, as set out on page 27 of this document.
- **ONLY** the **2023 SUMMATIVE ASSESSMENT SHEET**, your **completed and signed DECLARATION OF AUTHENTICITY**, the **completed 2023 CHECKLIST** and **ALL your presentations must be included** in the **correct sequence** in your PAT file/portfolio.
- You are **not permitted to use any of the photographs/pictures and/or websites contained in this PAT document**.
- Untidy and messy work, as well as the late submission of presentation requirements, will be penalised.

6. PRACTICAL ASSESSMENT TASK 1 (PAT 1)

A civil design project

Scenario

Your client's appeal to the local municipality to revoke the subdivision of stand 71 from two stands, 71A and 71B, to a single stand, has been successful. The **intention to build a new conference centre on stand 71** can now go ahead as planned as it would attract more business to the **existing bed and breakfast facility on the stand**. **You have been tasked** by your client to **submit a suggested design solution** for the **proposed new conference centre**.

The **proposed new conference centre** will simply be referred to as the **building** in the project from now on.

The **building**, which **must have the capacity to cater for a maximum of 65 delegates at a time, must be a single-storey brick structure and must also cater for people with disabilities.**

To match the design of the existing bed and breakfast facility, the **roof must be a Dutch gable design with an 'IBR' roof sheet finish, which also includes facia boards, gutters and rainwater downpipes. The **building must incorporate either an inner or outer curved wall as a prominent feature.****

The **main entrance must be north-facing and consist of a rotating door that has a single glass and aluminium swing door on either side. **Directly outside and in front of the rotating door must be a covered drive-through that is wide enough to accommodate two motor vehicles side by side for the dropping off and collecting of delegates. The **roof cover for the drive-through must be an extension of the Dutch gable roof design.******

The **main entrance must lead into a large open space/concourse within the building, with a floor area of no less than 110 m². The concourse will be utilised for plenary sessions, entertainment and dining purposes, and **must have a built-in reception desk near the main entrance.****

Leading off the concourse must be a small kitchen of approximately 10 m² which will be used for catering purposes. The kitchen **must have a single sink, built-in cupboards and sufficient work surfaces to prepare food, as well as space for a refrigerator and a stove. There must also be a built-in serving counter in the concourse, situated near the entrance to the kitchen.**

Leading off the concourse must also be THREE similarly sized meeting rooms that can accommodate up to 15 delegates, each with a floor area no larger than 36 m², as well as TWO similarly sized, but smaller, meeting rooms, each with a floor area of no larger than 24 m². The two smaller rooms must be adjacent to each other with a retractable wall divider between them so that it can be opened to form a single, larger room that will be able to accommodate up to 20 delegates. Each of the rooms must have a door that isolates it from the concourse and an emergency exit door to the outside of the building.

There **must be male and female toilet facilities, accessible from inside the building. The male toilet facility must have two separate toilets, three wall-mounted urinals and two hand wash basins. The female facility must have three separate toilets and three hand wash basins. There must also be a separate toilet facility with a toilet and a hand wash basin for disabled people. The **building must have sufficient electrical lighting and switched socket outlets in all the rooms and areas, as well as large windows to let in sufficient natural light. **All sewerage and waste-water from the building must be connected to the manhole on the municipal sewerage line.******

Included in the design must be a parking area, with **'at least' 12 standard parking bays** and two (2) parking bays for the disabled, situated close to the building.

The total area of the building, excluding the drive-through, may not exceed 320 m².

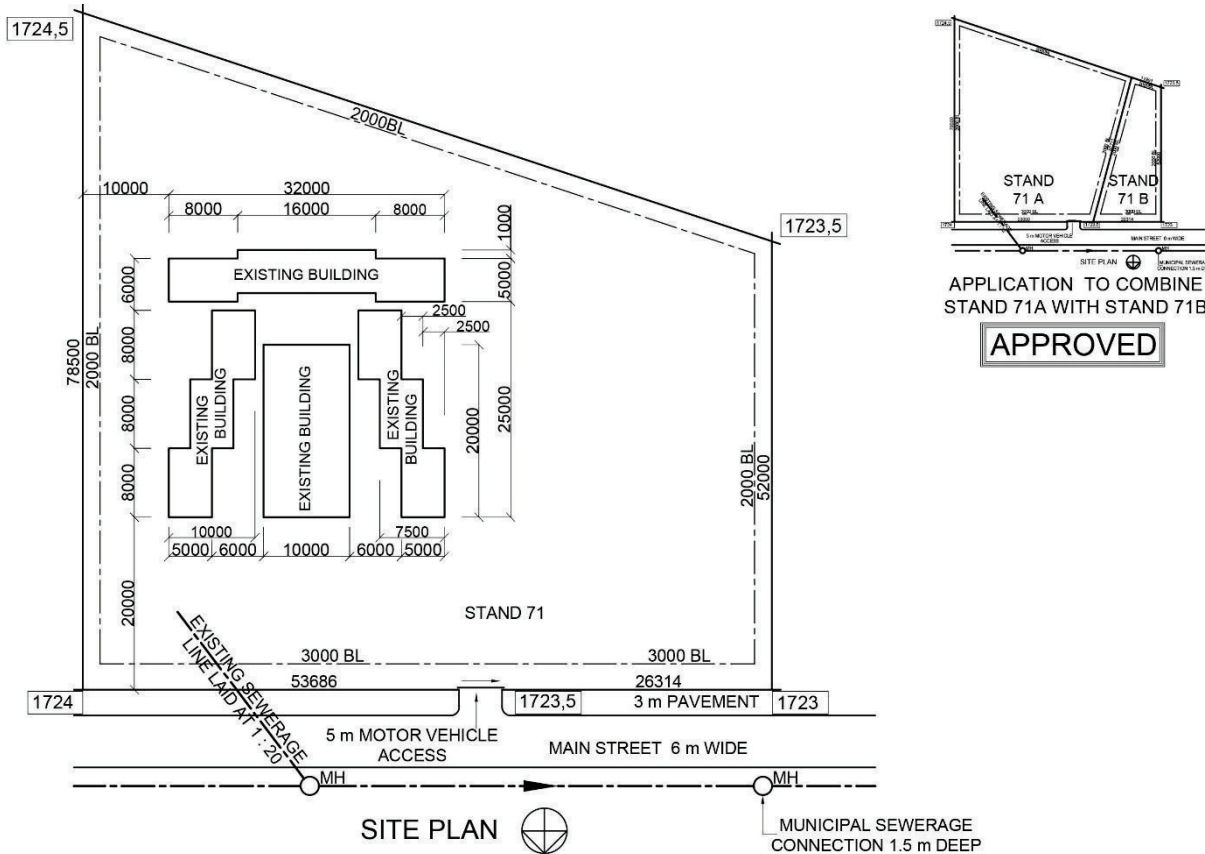

Given: The *'corrected'* site plan of stand 71
NOTE: The dimension of 84288 at the top of the of the site plan (i.e., south side of STAND 71) in the *'actual/official'* 2023 PAT document must be completely discarded/ignored!

PHASE 1: PRESENTATION REQUIREMENTS

- Analyse** the given scenario and formulate a design brief in two paragraphs:
 - The **first paragraph** must, in your own words, give a **brief background to the project**, as well as a **detailed description (as in/from the 1st, 2nd and 3rd paragraphs of scenario)** of what has to be designed.
 - The **second paragraph** must, in your own words, give a **clear overview of your role in the project**, as well as a **description of the complete DESIGN PROCESS** that you are going to implement to complete this project (PAT).

NOTE: Paragraphs **ONLY**, i.e., a ¼ to a ⅓ of a page, and **NOT** an essay!

From the scenario and your teacher's management plan, include the following as part of the design brief:

- A list of **20 (TWENTY)** of the given specifications for the building.
- A list of **FIVE possible constraints**. Note that the specifications that you have listed may not be repeated or reworded as possible constraints.

NOTE:

- It is recommended to first identify and list the FIVE constraints, and to then identify and list the TWENTY 'other' specifications!*
- Each specification & constraint must be 'numbered/bulleted' individually!*
- Your own management plan** that specifies target dates for the completion of each presentation requirement.

1. Design Brief				
1.1	1 st paragraph: background and comprehensive description of what is to be designed		2	
1.2	2 nd paragraph: your role and description of the design process you are going to follow		2	
1.3	A list of TWENTY given specifications from the scenario		2	
1.4	A list of FIVE possible constraints from the scenario		2	
1.5	A management plan with possible target dates for ALL the presentation requirements		2	
			TOTAL	10

2. Conduct research on:

- Designs and floor-plan layouts of small conference centres
- THREE examples of Dutch gable roof designs and THREE examples of covered drive-throughs
- Designs and construction details of rotating doors with a swing door(s) on the side(s)

NOTE:

- The research must be relevant (usable) and should therefore be in the form of graphic material, i.e., ‘of relevant’ pictures and/or illustrations ‘for each topic’.
- Evidence of at least FIVE different examples of each research topic must be included in the PAT file/portfolio, ‘unless otherwise stated’, i.e., for this PAT only for the research on small conference centres and rotating doors requires FIVE examples, as the other TWO each requires only THREE examples.
- The research material must be aesthetically presented and may NOT exceed FOUR A4 or TWO A3 pages per topic.
- There must be clear evidence that the research has been used in your ‘proposed’ design solution.
- Include a list of ALL references used (Bibliography) directly after the research (i.e., as part of the presentation of the research).

2.	Research (This should be restricted to a maximum of FOUR A4 or TWO A3 pages per topic.)				
Relevant and usable research on:	2.1	Designs and floorplan layouts of small conference centres		2	
	2.2	THREE Dutch gable roof designs (1) + THREE covered drive-throughs (1)		2	
	2.3	Designs and construction detail of rotating door with side swing doors		2	
		Clear evidence that the research was used in design solutions		2	
		A list of ALL references used (Bibliography)		2	
	TOTAL			10	

3. Prepare neat detailed freehand drawings of the floor-plan layout of TWO possible design solutions for the proposed new building, including the drive-through in front of the rotating door. Each freehand drawing must show the correct presentation of ALL the building features, the permanent fixtures, the roofline, as well as the primary dimensions and labels. The calculation for the total area of the building and the floor area of the concourse must be clearly shown in a table on the drawing sheet of each freehand drawing.

NOTE:

- Grid/Graph paper must be used to assist with the preparation of the freehand drawings so that ALL features and fixtures are drawn to proportion. The grid/graph paper used must be included in the PAT file/portfolio (as evidence).
NOTE:
 - It is recommended that the reverse (clean) side of copies of ‘darker/clearer’ grids, as found in the back of the EGD textbooks, be used for the freehand drawings, or to simply use a copy as a ‘backing’ to clean drawing sheets.
 - If freehand drawings are going to be drawn directly on grids, the grids must be of a much lighter ‘other’ colour, e.g., light blue, light green, light pink, so that quality and darkness of line types will not have to be changed!
 - Explain using the ‘block sizes’ as the scale, e.g., 1 Block = 500 x 500.
- ALL aspects of the freehand drawing, including dimensions, tables, labels, and possible information blocks must be prepared using a pencil ONLY. The use of any other drawing instruments, e.g., a ruler or compass, will be penalised.
- Electrical fittings and the waste-water disposal systems are NOT required on the freehand drawings.
- The drawings may be prepared on either A4 or A3 drawing sheets.
- NO borders or title panels are required for the drawing sheets.

- **ALL the freehand drawings must comply** with the **guidelines** and **graphical symbols** contained in the **SANS 10143**.
- The drawings **must provide clear evidence** that a **high level of competency** has been attained in the **freehand drawing method**.

Additional NOTES on the FREEHAND DRAWINGS:

The following ROOMS/AREAS and BUILDING FEATURES are required for the 1st mark (criteria) out of '2':	The following FIXTURES are required for the 4th mark (criteria) out of '2':
<p>Conference centre that includes:</p> <ul style="list-style-type: none"> • Covered drive-through (2 cars wide) • Large open space/concourse • Small kitchen of ± 10 m² • 3 x similarly sized ≤ 36 m² meeting rooms • 2 x similarly sized ≤ 24 m² meeting rooms next to each other • Doors from ALL meeting rooms and the kitchen to the concourse • Exterior emergency exit doors from each meeting room • Male toilet facilities • Female toilet facilities • Toilet facility for disabled people • Large windows for ALL rooms/areas 	<ul style="list-style-type: none"> • In open space/concourse: <ul style="list-style-type: none"> ○ built-in reception desk near entrance ○ built-in serving counter near the entrance to the kitchen • In kitchen: <ul style="list-style-type: none"> ○ sufficient work surfaces ○ built-in cupboards ○ single sink ○ space a refrigerator ○ space for a stove • In male toilet facilities: <ul style="list-style-type: none"> ○ 2 x separate toilet (for disabled) ○ 3 x wall-mounted urinal ○ 2 x hand-wash basins • In female toilet facilities: <ul style="list-style-type: none"> ○ 3 x separate toilets ○ 3 x hand-wash basins • In toilet facility for disabled people: <ul style="list-style-type: none"> ○ 1 x toilet & ○ 1 x hand-wash basin
RELATIVE SIZE/PROPORTION of ALL features to each other refers to the following:	
ALL the building features and ALL the fixtures are drawn to a SIMILAR SCALE!	
ONLY the following 2 X CALCULATIONS are required:	
TOTAL AREA of the entire BUILDING (conference centre), excluding the drive-through , which may be maximum 320 m² for the '2 marks' to be allocated!	FLOOR AREA (excluding the walls) of the CONCOURSE (open space), which must be minimum 110 m² for the '2 marks' to be allocated!
<p>NOTE:</p> <ul style="list-style-type: none"> • For '1-mark' to be allocated, the calculation must show knowledge of the correct formula to be used, and an understanding of what needs to be calculated! • A learner could use either the dimensions, or simply the 'blocks' of the grid paper. • If a/the calculation(s) of a freehand drawing is NOT in a table(s), = '- 1 mark' ONLY for both calculations of that freehand drawing (i.e., a penalty for an instructional mistake). 	
The following DESIGN ASPECTS must also be adhered to for '2-marks' to be allocated:	
<ul style="list-style-type: none"> • The building must be a single-storey brick structure • The entire building/conference centre must be disability-friendly • The toilet facility of disabled people must be larger for people in wheelchairs 	

3.	Freehand drawings of TWO possible design solutions	Final mark for each solution			
Assess each freehand solution as follows:	Building includes ALL required rooms/areas + is disability-friendly	2	Solution 1	10	
	Prominent curved wall (1) + rotating door & drive-through (1)	2			
	Correct presentation of building features (roofline, walls, doors, etc.)	2			
	ALL fixtures included (WCs, sink, built-in reception desk, etc.)	2			
	Correct presentation of all fixtures according to SANS 10143	2			
	The relative size + proportion of ALL features to each other	2	Solution 2	10	
	Primary labels (1) + primary dimensions (1)	2			
	2 x calculations shown and within the specifications (2 + 2 = 4)	4			
	Design, functionality + effective space utilisation	2			
	Subtotal = 20 ÷ 2 = TOTAL	20			

a.	Freehand drawings		
	Freehand drawing method and skills (See ANNEXURE A on page 24) NOTE: • No evidence of grid/graph paper used = max. 7 marks , even if drawn excellently • Not drawn in freehand = 0 marks, & some evidence of instruments used = max. 5 marks	10	
	Neatness (2) + correct line types used (2) + line consistency (2) + printing (2) + dimensioning (2) (Also see ANNEXURE A on page 24)	10	

NOTE:

- **NO freehand drawings, = '0' marks for both 'method & skills' and 'presentation', i.e., = '0' out of '20'!**
- **The mark allocations for final drawing presentation: Neatness (2); Correct line types used (2); Line consistency (2); Printing/writing (2); Dimensioning (2)**

Additional NOTE on 'Freehand drawing method and skills (m & s):

This refers to **'pencil control (hand movement), e.g., straightness of lines, quality of curves etc., the effective utilisation of the blocks/grids', and the ability to 'draw to proportion'.**

Additional NOTES on the 'Final drawing presentation' (i.e., the 2nd criteria out of '10'):

- **'Correct line types used' refers to 'A-type', 'B-type', 'C-type', 'Medium chain-line' etc.**
- **'Line consistency' refers to the consistency of the 'darkness' of the 'specific line-types'.**
- **If ALL or most of the two freehand drawings, including all or any aspects thereof, were drawn with anything other than PENCIL, e.g., a drawing pen, = '0'(zero) marks for 'correct line types used', and = '0'(zero) marks for 'line consistency'!**
- **If most of the freehand drawings were drawn in PENCIL, but some or any aspects thereof were drawn with anything other than PENCIL, = - 1 mark penalty on the total out of '10'!**
- **'Printing' and 'dimensioning' refers to compliance with the SANS 10143 guidelines.**

4. **Select the best solution** that demonstrates an in-depth understanding of the scenario within the context of the design brief.

On a separate page, compare and evaluate the TWO freehand solutions by:

- **Creating a table** with a **minimum of SIX relevant and descriptive criteria** that will **facilitate measurable comparisons**. **NOTE: NOT just a 'word', but a self-explanatory criterion!**
- **Creating and applying a simple, self-explanatory rating scale** to score each solution against each criterion (**You must explain the values of your scale!**).
- **Justifying each score** by describing the **positive and/or negative aspects** of each solution against each criterion

Complete the process by writing a comprehensive summary giving reasons for your selected freehand solution. The summary must include whether **any late changes were made** to the selected freehand solution, **or not**. If there were late changes, they must be **clearly described**.

4.	Selecting the best freehand solution (This must be a separate presentation.)		
	A suitable table created for the selection process		2
	A minimum of SIX relevant and descriptive criteria that will facilitate measurable comparisons		2
	A simple rating scale created and used to score each solution against each criterion		2
	Each score justified by describing the positive or negative aspects against each criterion		2
	Comprehensive summary with reasons for selected solution (including possible late changes)		2
		TOTAL	10

PHASE 2: PRESENTATION REQUIREMENTS

5. **Present** the **selected solution** as a **set of working drawings** and a **pictorial drawing** (5.1, 5.2 and 5.3) that meet the following criteria:
 - **All the working drawings** must be prepared on **appropriately sized drawing sheets, set up with correct borders. ONLY ONE** of the drawing sheets must be set up with a **complete CIVIL TITLE PANEL** (see p. 28 of this document).
NOTE: If space is a problem due to the scale, use SITE PLAN for title panel!

- The drawings must provide clear evidence that a **high level of competency has been attained** in the following TWO drawing method:
 - Instrument drawing
 - CAD (computer-aided drawing/design)
- NOTE:**
 - ONE entire working drawing (i.e., 5.1.1, 5.1.2 and 5.1.3 or 5.2) must be prepared using a pencil and drawing instruments and the other using a CAD program.**
 - The perspective drawing (5.3) may be prepared using either drawing instruments or a CAD program.
 - Schools that do NOT have CAD facilities must prepare ALL the required working drawings and pictorial drawing (i.e., 5.1, 5.2 and 5.3) using a pencil and drawing instruments.**
- The **title panel** and **ALL aspects of all drawings must comply with** the guidelines, drawing symbols, graphical symbols and representations contained in the **SANS 10143**.

5.	Layout drawings and a pictorial drawing of selected solution			
	Drawing sheet preparation			
	Appropriately sized drawing sheets		1	
	Borders on all the drawing sheets of all the working drawings		2	
	Complete SANS 10143 compliant CIVIL TITLE PANEL on ONE working drawing's drawing sheet		7	
	NOTE: Use the 7-mark simplified rubric on page 45 of the CAPS.	TOTAL	10	

- 5.1 **Draw detailed LAYOUT DRAWINGS** of the selected freehand solution of the **complete building**, clearly showing **ALL the required building features**, including the **drive-through**.

The layout drawings must show the following orthographic views:

- 5.1.1 The complete **FLOOR PLAN**, drawn to a **suitable scale**, but **preferably not smaller than scale of 1 : 75 (i.e., preferably 1 : 50 or 1 : 75)**.
- 5.1.2 **TWO ELEVATIONS**, drawn to the **same scale as the floor plan**, with one view showing the **front entrance to the building**, and the other showing a **side view**. It is recommended to draw the elevations that would be required for the two-point perspective drawing.
- 5.1.3 A **DETAILED SECTION(S)**, drawn to **scale 1 : 20**, showing **ALL** the detail from the foundation to the roof, on a cutting plane that passes through the **rotating door** in the main entrance, and a **window (on the/another side)**.
NOTE: Use break lines to divide the detailed section into **TWO, or more, parts**, with the one part **wide enough** to show the **complete rotating door** and a **1½ m section** of the **covered drive-through**, and the other part **wide enough** to show the **window** and the **end of the roof**.

Include the following **on ALL relevant views**:

- ALL exterior features, including door and window detail.
NOTE: **ALL window and door frames** must be shown in the TWO elevations
- The roof detail, including all rainwater items and roof lines
- ALL permanent fixtures (*according to symbols in the SANS 10143*)
- ALL electrical fittings and the wiring detail
- Waste-water disposal systems (sewerage)
- Titles, labels and notes (*see p. 29 of this document for examples*)
- Scales used
- Detailed dimensioning
- Cutting plane(s)
- ALL hatching detail
- North point

5.1	Detailed layout drawings of the proposed new building and covered walkway			
5.1.1	FLOOR PLAN showing:			
	Correlation with selected freehand solution and selection process summary		2	
	ALL internal and external walls and rooflines		2	
	ALL doors, including the rotating door, and windows		2	
	ALL permanent fixtures		2	
	ALL electrical fittings and the wiring detail		2	
	Waste-water disposal systems (sewerage)		2	
	Title, labels and notes		2	
	Detailed dimensioning		2	
	Hatching detail (1) + Cutting plane (1)	(1 + 1 = 2)	2	
	Suitable scale selected and correctly indicated (1) + North point (1)	(1 + 1 = 2)	2	
	Subtotal = 20 ÷ 2 = TOTAL			10

5.1.2	TWO ELEVATIONS that show the front entrance and a side view of the building			
	Prescribed views shown (front entrance to building and a side view)		2	
	External walls and covered drive-through at main entrance		2	
	ALL door and window detail, including the door and window frames		2	
	Dutch gable roof detail, including rainwater items		2	
	Waste-water disposal system (sewerage)		1	
	Elevations drawn to the same scale as the floor plan		1	
	TOTAL			10

5.1.3	DETAILED SECTION in two parts			
	Both parts of the section correct according to the indicated cutting plane(s)		2	
	Foundation, slab and wall detail on both parts		2	
	Rotating door detail		2	
	Detail of 1½ m section of covered drive-through		2	
	Window detail		2	
	Roof detail, including relevant rainwater items, on both parts		2	
	Titles, labels and notes		2	
	Detailed dimensioning		2	
	ALL hatching detail		2	
	Scale 1 : 20 used and indicated correctly (1) + Break lines (1)	(1 + 1 = 2)	2	
	Subtotal = 20 ÷ 2 = TOTAL			10

5.2 Draw, to a suitable scale, a complete detailed **SITE PLAN** of *'the entire'* STAND 71.

Include the following:

- ALL the *'given'* site details and features, including ALL existing buildings
- The **proposed new building**, parking area and driveways
- **ALL sewerage detail**, with labels and notes included
- **Dimensions**, including the reference dimensions and corner heights
- **Scale**
- **North point**

5.2	Detailed SITE PLAN			
	Site plan correctly drawn, including ALL given site features and detail		2	
	The proposed new building with north-facing main entrance, parking area and driveways		2	
	ALL sewerage detail, with labels and notes included		2	
	Dimensions, including new building's reference dimensions and corner heights		2	
	Suitable scale indicated correctly		1	
	North point		1	
	TOTAL			10

5.2 Draw a **'large' detailed 'human eye view' TWO-POINT PERSPECTIVE DRAWING 'of the building'** that **shows the main entrance and rotating door** to the building. The **horizon line (HL)** must be **±1,5 m above the ground line (GL)**.

Evidence of the following must be included *'with the perspective drawing'*:

- All views/drawings used to produce the perspective drawing
NOTE: These can be placed in a plastic sleeve in the PAT portfolio.
- The **construction method used** to produce the perspective drawing

NOTE: The perspectives should **NOT look like a Test or Exam Paper question for a perspective drawing!!** By **using copies of the FLOOR PLAN and the ELEVATIONS of 5.1.1 & 5.1.2**, the perspectives should be a **'larger drawing' in the centre of an A3 drawing sheet!**

NOTE: Use a **copy of the perspective drawing**, which may contain artistic features, **as the picture for the cover page** of your **PAT file/portfolio**.

5.3	TWO-POINT PERSPECTIVE DRAWING showing the entrance to conference centre		
	Evidence of the views and construction used to prepare the drawing	2	
	Correct orientation of the building with the HL at ±1,5 m above the ground line (GL)	1	
	Detail and correctness of the perspective drawing	7	
		TOTAL	10

The following is for 5.1 (i.e., 5.1.1, 5.1.2 & 5.1.3), 5.2 and 5.3

b.	Instrument drawings		
	Use of drawing instruments, drawing method and skills (See ANNEXURE A on page 24)	10	
	Neatness (2) + correct line types used (2) + line consistency (2) + printing (2) + dimensioning (2) (Also see ANNEXURE A on page 24)	10	

NOTE:

- **NO instrument drawings at all, e.g., ALL drawing done in CAD, or in freehand = '0' marks for both 'method & skills' and 'presentation', i.e., = '0' out of '20'!**
- The mark allocations for final drawing presentation: **Neatness (2); Correct line types used (2); Line consistency (2); Printing/writing (2); Dimensioning (2)**

Additional NOTE on 'Instrument drawing method and skills (m & s):

This refers to **'using the relevant instruments correctly, and pencil control.**

Additional NOTES on the 'Final drawing presentation' (i.e., the 2nd criteria out of '10'):

- **'Correct line types used'** refers to **'A-type', 'B-type', 'C-type', 'Medium chain-line' etc.**
- **'Line consistency'** refers to the **consistency of the 'darkness' of the 'specific line-types'.**
- If **ALL or most of the two instrument drawings, including all or any aspects thereof, were drawn with anything other than PENCIL, e.g., a drawing pen, = '0'(zero) marks for 'correct line types used', and = '0'(zero) marks for 'line consistency'!**
- If most of the freehand drawings were drawn in PENCIL, but **some or any aspects thereof were drawn with anything other than PENCIL, = - 1 mark penalty on the total out of '10'!**
- **'Printing' and 'dimensioning'** refers to compliance with the **SANS 10143 guidelines.**

c.	CAD drawings		
	Competence displayed in using a CAD program (See ANNEXURE A on page 24)	10	
	Layout and correctness of the drawings presentation (See ANNEXURE A on page 24)	10	

NOTE: ANNEXURE A is also included on page 31 of this document!

PHASE 3: PRESENTATION REQUIREMENTS

Create a PAT file/portfolio containing the following in the given sequence:

- A **complete cover page** that includes the school's name and centre number, **your full name and surname**, grade and class group, **your teacher's initials and surname**, and a copy of your own two-point perspective drawing for this task.
- A **complete table of contents (index)**
- The **2023 SUMMATIVE ASSESSMENT SHEET** (see page 26 of the 'actual' PAT document, *'or page 33 of this document'*)
- The **completed DECLARATION OF AUTHENTICITY** (see page 27 of the 'actual' PAT document, *'or page 34 of this document'*)

Include the following PHASE 1 and PHASE 2 presentation requirements in the PAT file/portfolio **AFTER** the DECLARATION OF AUTHENTICITY:

1. ALL the **design brief** requirements
2. Evidence of ALL the **resource material used** for the required research
3. The **TWO freehand drawings** of the possible design solutions
4. ALL the evidence of the **selection of the best solution**
5. ALL the required **working drawings** (5.1 and 5.2) and the **perspective drawing** (5.3)
6. The **'ASSESSMENT CRITERIA AND CHECKLIST FOR THE 2023 CIVIL PAT'** (see pages 15 and 16), which **must provide clear evidence of your own continuous self-evaluation** and the **meeting of the deadlines during the development of the PAT**.
NOTE: 'Individual' CHECKLISTS cut from the 'combined 'ASSESSMENT CRITERIA AND CHECKLIST FOR THE 2023 CIVIL PAT' may also be used!

6.	Continuous self-evaluation and the meeting of deadlines			
	Completed checklist as evidence of continuous self-evaluation	(mark out of 10 ÷ 2)	5	
	Meeting ALL the submission deadlines	(mark out of 10 ÷ 2)	5	
TOTAL			10	

NOTE:

Include the following **on each page**:

- **Clear numbering** according to the numbers of the presentation requirements
- **Your** (the learner's) **name** and the **date of completion** and **submission**

7.	Presentation of the complete PAT file/portfolio			
	Complete cover page with a copy of the perspective drawing		1	
	Table of contents		1	
	Completed summative assessment sheet and declaration		1	
	Correct sequencing of ALL presentation requirements		1	
	Name and numbering on ALL the presentation requirements		1	
	General impression of file/portfolio, e.g. binding, appearance, etc.	(mark out of 10 ÷ 2)	5	
TOTAL			10	

Assessment criteria and checklist for the 2023 Civil PAT

- The SUMMATIVE ASSESSMENT SHEET on page 26 of the PAT document, *'or page 30 of this document'*, must be used to indicate the final totals out of 10 for each assessment criterion.
- The contribution of each aspect of the PAT is as follows:
 - The design process, i.e. presentation requirements numbers 1, 2, 3, 4, 6 and 7, will contribute 25 marks out of 100.
 - The working drawings and the pictorial drawing, i.e. presentation requirement number 5, will contribute 50 marks out of 100.
 - Drawing method, drawing skills and presentation, which should be assessed according to ANNEXURE A, will contribute 25 marks out of 100.

NOTE: ALL the Grade 12 PATs must, without exception, be completed and ready for final assessment by Friday 04 August 2023!

ASSESSMENT CRITERIA AND CHECKLIST FOR THE 2023 CIVIL PAT								
1-mark level descriptive	0	Requirement not met or presented incorrectly				Checked	Maximum mark	Comments
	1	Requirement has been met and/or presented correctly						
2-mark level descriptive	0	Requirement not met, or less than 30% evidence of knowledge shown (very poor)				Checked	Maximum mark	Comments
	1	Requirement included and at least 30%+ evidence of knowledge shown (avg.)						
	2	Presentation shows at least 80% or more evidence of knowledge (very good)						
1. Design Brief								
1.1	1 st paragraph: background and comprehensive description of what is to be designed					2		
1.2	2 nd paragraph: your role and description of the design process you are going to follow					2		
1.3	A list of 20 (<i>TWENTY</i>) given specifications from the scenario					2		
1.4	A list of FIVE possible constraints from the scenario					2		
1.5	A management plan with possible target dates for ALL the presentation requirements					2		
TOTAL						10		
2. Research (This should be restricted to a maximum of FOUR A4 or TWO A3 pages per topic.)								
Relevant and usable research on:	2.1	Designs and floorplan layouts of small conference centres					2	
	2.2	THREE Dutch gable roof designs (1) + THREE covered drive-throughs (1)					2	
	2.3	Designs and construction detail of rotating door with side swing doors					2	
	Clear evidence that the research was used in design solutions					2		
	A list of ALL references used (Bibliography)					2		
TOTAL						10		
3. Freehand drawings of TWO possible design solutions					Final mark for each solution			
Assess each freehand solution as follows:	Building includes ALL required rooms/areas + is disability-friendly		2	Solution 1	10			
	Prominent curved wall (1) + rotating door & drive-through (1)		2					
	Correct presentation of building features (roofline, walls, doors, etc.)		2					
	ALL fixtures included (WCs, sink, build-in reception desk, etc.)		2					
	Correct presentation of all fixtures according to SANS 10143		2					
	The relative size + proportion of ALL features to each other		2	Solution 2	10			
	Primary labels (1) + primary dimensions (1)		2					
	2 x calculations shown and within the specifications (2 + 2 = 4)		4					
	Design, functionality + effective space utilisation		2					
Subtotal = 20 ÷ 2 = TOTAL			20					
4. Selecting the best freehand solution (This must be a separate presentation.)								
A suitable table created for the selection process						2		
A minimum of SIX relevant and descriptive criteria that will facilitate measurable comparisons						2		
A simple rating scale created and used to score each solution against each criterion						2		
Each score justified by describing the positive or negative aspects against each criterion						2		
Comprehensive summary with reasons for selected solution (including possible late changes)						2		
TOTAL						10		
5. Layout drawings and a pictorial drawing of selected solution								
Drawing sheet preparation								
Appropriately sized drawing sheets						1		
Borders on all the drawing sheets of all the working drawings						2		
Complete SANS 10143 compliant CIVIL TITLE PANEL on ONE working drawing's drawing sheet						7		
NOTE: Use the 7-mark simplified rubric on page 45 of the CAPS.								
TOTAL						10		
5.1 Detailed layout drawings of the proposed new building and covered walkway								
5.1.1	FLOOR PLAN showing:							
	Correlation with selected freehand solution and selection process summary					2		
	ALL internal and external walls and rooflines					2		
	ALL doors, including the rotating door, and windows					2		
	ALL permanent fixtures					2		
	ALL electrical fittings and the wiring detail					2		
	Waste-water disposal systems (sewerage)					2		
	Title, labels and notes					2		
	Detailed dimensioning					2		
	Hatching detail (1) + Cutting plane (1)		(1 + 1 = 2)			2		
	Suitable scale selected and correctly indicated (1) + North point (1)		(1 + 1 = 2)			2		
Subtotal = 20 ÷ 2 = TOTAL						10		

ASSESSMENT CRITERIA AND CHECKLIST FOR THE 2023 CIVIL PAT				
5.1.2	TWO ELEVATIONS that show the front entrance and a side view of the building			
	Prescribed views shown (front entrance to building and a side view)		2	
	External walls and covered drive-through at main entrance		2	
	ALL door and window detail, including the door and window frames		2	
	Dutch gable roof detail, including rainwater items		2	
	Waste-water disposal system (sewerage)		1	
	Elevations drawn to the same scale as the floor plan		1	
			TOTAL	10
5.1.3	DETAILED SECTION in two parts			
	Both parts of the section correct according to the indicated cutting plane(s)		2	
	Foundation, slab and wall detail on both parts		2	
	Rotating door detail		2	
	Detail of 1½ m section of covered drive-through		2	
	Window detail		2	
	Roof detail, including relevant rainwater items, on both parts		2	
	Titles, labels and notes		2	
	Detailed dimensioning		2	
	ALL hatching detail		2	
	Scale 1 : 20 used and indicated correctly (1) + Break lines (1)	(1 + 1 = 2)	2	
			Subtotal = 20 ÷ 2 = TOTAL	10
5.2	Detailed SITE PLAN			
	Site plan correctly drawn, including ALL given site features and detail		2	
	The proposed new building with north-facing main entrance, parking area and driveways		2	
	ALL sewerage detail, with labels and notes included		2	
	Dimensions, including new building's reference dimensions and corner heights		2	
	Suitable scale indicated correctly		1	
	North point		1	
			TOTAL	10
5.3	TWO-POINT PERSPECTIVE DRAWING showing the entrance to conference centre			
	Evidence of the views and construction used to prepare the drawing		2	
	Correct orientation of the building with the HL at ±1,5 m above the ground line (GL)		1	
	Detail and correctness of the perspective drawing		7	
			TOTAL	10
6.	Continuous self-evaluation and the meeting of deadlines			
	Completed checklist as evidence of continuous self-evaluation	(mark out of 10 ÷ 2)	5	
	Meeting ALL the submission deadlines	(mark out of 10 ÷ 2)	5	
			TOTAL	10
7.	Presentation of the complete PAT file/portfolio			
	Complete cover page with a copy of the perspective drawing		1	
	Table of contents		1	
	Completed summative assessment sheet and declaration		1	
	Correct sequencing of ALL presentation requirements		1	
	Name and numbering on ALL the presentation requirements		1	
	General impression of file/portfolio, e.g. binding, appearance, etc.	(mark out of 10 ÷ 2)	5	
			TOTAL	10
Assessment of drawing method, drawing skills and presentation				
a.	Freehand drawings			
	Freehand drawing method and skills	(See ANNEXURE A on page 24)	10	
	NOTE: • No evidence of grid/graph paper used = max. 7 marks, even if drawn excellently • Not drawn in freehand = 0 marks, & some evidence of instruments used = max. 5 marks			
	Neatness (2) + correct line types used (2) + line consistency (2) + printing (2) + dimensioning (2)	(Also see ANNEXURE A on page 24)	10	
b.	Instrument drawings			
	Use of drawing instruments, drawing method and skills	(See ANNEXURE A on page 24)	10	
	Neatness (2) + correct line types used (2) + line consistency (2) + printing (2) + dimensioning (2)	(Also see ANNEXURE A on page 24)	10	
c.	CAD drawings			
	Competence displayed in using a CAD program	(See ANNEXURE A on page 24)	10	
	Layout and correctness of the drawings presentation	(See ANNEXURE A on page 24)	10	

7. PRACTICAL ASSESSMENT TASK 2 (PAT 2)

A mechanical design project

SCENARIO

A clamp or clamping device is designed to hold components firmly in place, either temporarily or permanently, and are therefore versatile tools that often have multiple applications.

You are employed by a mechanical design firm that specialises in improving the design and function of complex CLAMPS and CLAMPING DEVICES. The firm is currently working on design solutions to improve the functionality of existing clamps and clamping devices. **Examples** of some of these complex **clamps** and **clamping devices** are shown below.



Trigger clamp
[Source: shopwl.com]



Wheel clamp
[Source: maypoleltd.com]



Pull clamp
[Source: m.indiamart.com]

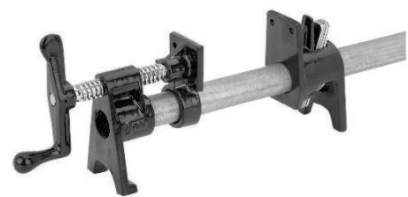

Pipe clamp
[Source: leevalley.com]

As a design consultant for the firm, you have been tasked with investigating and analysing the design features of complex clamps and clamping devices and to then design an improvement(s) which could be, but is not limited to, one or more of the following:

- Improved efficiency
- To strengthen its design
- To modify its design

Your investigation, analysis and solution require the following stages:

- The **FIRST stage** involves **finding a suitable complex clamp or clamping device**. The clamp or clamping device **must incorporate a mechanical mechanism, a screw mechanism and/or a mechanical locking device**, and must **consist of a minimum of FOUR parts**. The clamp or clamping device that you have selected **will simply be referred to as the clamp** in the project from now on.

NOTE:

You are **NOT required to purchase a clamp**. The clamp you have selected should therefore be one that is **readily (already) available to you**.

- The **SECOND stage** involves **dismantling the clamp** so that **ALL the individual parts can be investigated, measured, and photographed**.
- The **THIRD stage** requires the **identification of either the mechanical mechanism, the screw mechanism, the mechanical locking device, a complex (intricate) main part, or a combination of parts of the clamp**, which could be improved, strengthened or modified in some way.
This will necessitate the **application of the design process**, as stipulated below in the presentation requirements.

Requirements and specifications for the clamp:

- **Each learner MUST have his/her own clamp for the PAT.**
- Your selected clamp **MUST** be submitted (*together with your PAT file/portfolio*) as part of your PAT presentation.
- The clamp that you have selected **must incorporate** a mechanical mechanism, screw mechanism and/or a mechanical locking device, with a minimum of FOUR parts.
- Electrical, electronic or pneumatic clamps or clamping devices **may NOT** be used.
- **Your teacher must approve the clamp that you have selected.** This is to ensure that it meets the requirements and that a PAT of an appropriate higher-order Grade 12 complexity can be produced.

PHASE 1: PRESENTATION REQUIREMENTS

1. **Analyse** the given scenario and formulate a design brief in two paragraphs:
 - The **first paragraph** must, in your own words, give a brief background to the project, as well as a detailed description (as in/from the 1st and 2nd paragraphs of scenario) of what has to be designed (what is required to be done).
 - The **second paragraph** must, in your own words, give a clear overview of your role in the project (as in/from the 3rd paragraph of scenario), as well as a description of the complete DESIGN PROCESS that you are going to implement to complete this project (PAT).

NOTE: Paragraphs ONLY, i.e., a ¼ to a ⅓ of a page, and NOT an essay!

From the given scenario and your teacher's management plan, include the following as part of the design brief:

- **Your own list** of ALL the specifications (at least THREE) for your selected clamp
- **Your own list** of at least THREE constraints of your selected clamp.

NOTE:

- *The specifications may NOT be repeated or reworded as constraints!*
- *It is recommended to first identify the THREE constraints, and to then list everything else as the specifications!*
- *Each specification & constraint must be 'numbered/bulleted' individually!*
- **Your own management plan (aligned to the teacher's management plan)**, which specifies target dates for the completion of each presentation requirement.

1.	Design Brief		
1.1	1 st paragraph: background and comprehensive description of what is to be designed		2
1.2	2 nd paragraph: your role and description of the design process you are going to follow		2
1.3	A list of ALL the specifications of your clamp		2
1.4	A list of at least THREE constraints of your clamp		2
1.5	A management plan with target dates for ALL the presentation requirements		2
TOTAL			10

2. **Conduct research** on:
 - The material used for each individual part of your selected clamp
 - The specific design features and/or function/purpose of each individual part of your selected clamp
 - The design and components of at least ONE other clamp or clamping device that is similar to your selected clamp.

NOTE:

- The research **must be relevant (usable)** and should therefore **be in the form of graphic material**, i.e., **'of relevant' pictures and/or illustrations 'for each topic'**.
- **Evidence** of ALL the required research material **must** be included in the **PAT portfolio**.
- The research material must be aesthetically presented and may NOT exceed FOUR A4 or TWO A3 pages per topic.

- The **first two research requirements** will be primarily **hands-on investigative research**, which must be presented using a **comprehensive set of detailed photographs** taken during the second stage. **Include labels and/or notes indicating the material and the function (purpose) of each individual part/component.**
- The **evidence of the ONE other similar clamp** may be in the form of a **comprehensive set of pictures, illustrations and/or photographs**, together with **explanatory labels and notes.**
- There must be **clear evidence** that the **research was used** in your design solution.
- **Include a list of ALL references used (Bibliography) directly after the research (i.e., as part of the presentation of the research).**

2.	Research (This should be restricted to a maximum of THREE A4 or TWO A3 pages per research topic.)				
Relevant and usable research on:	2.1	Materials used for each component of your clamp		2	
	2.2	Design features/function/purpose of each component of your clamp		2	
	2.3	The design, components, mechanisms, etc. of another similar clamp		2	
	Clear evidence that the research was used in your design solutions			2	
	A list of ALL references used (Bibliography)			2	
TOTAL				10	

3. Prepare **neat detailed freehand drawings** of **TWO possible design solutions** of the proposed improvement, strengthening or modification of the identified mechanical mechanism, screw mechanism, mechanical locking device, complex (intricate) main part, or combination of parts of **your selected clamp.**

Each set of freehand drawings must consist of **relevant orthographic views** and an **isometric drawing(s).** **ALL freehand drawings must show the correct presentation of ALL the features** and include **dimensions, labels and explanatory notes.** Include a **short (narrative) explanation** of the possible improvement, strengthening or modification.

NOTE:

- **Grid/Graph paper must be used** to assist with the preparation of the freehand drawings so that **ALL features and fixtures are drawn to proportion.** The **grid/graph paper used must be included** in the PAT file/portfolio **(as evidence).**
NOTE:
 - *It is recommended that the reverse (clean) side of copies of ‘darker/clearer’ grids, as found in the back of the EGD textbooks, be used for the freehand drawings, or to simply use a copy as a ‘backing’ to clean drawing sheets.*
 - *If freehand drawings are going to be drawn directly on grids, the grids **must be of a much lighter ‘other’ colour, e.g., light blue, light green, light pink, so that quality and darkness of line types will not have to be changed!***
 - ***Explain using the ‘block sizes’ as the scale, e.g., 1 Block = 2 x 2 mm.***
- **ALL aspects of the freehand drawing**, including dimensions, tables, labels, and possible information blocks **must be prepared using a pencil ONLY.** The use of **any other drawing instruments, e.g., a ruler or compass, will be penalised.**
- The drawings may be prepared **on either A4 or A3 drawing sheets.**
- **NO borders or title blocks are required for the drawing sheets.**
- **ALL the freehand drawings must comply** with the **guidelines and conventional representations** contained in the **SANS 10111.**
- The drawings **must provide clear evidence** that a high level of competency has been attained in the freehand drawing method.

3. Freehand drawings of TWO possible design solutions				Final mark for each solution		
Assess each freehand solution as follows:	Third-angle orthographic views of the identified part(s)	2	Solution 1		10	
	Isometric drawing of the identified part(s)	2				
	Correct presentation of ALL the parts and features	1				
	Relative proportion of ALL parts and features to each other	2				
	Labels and explanatory notes	2				
	Dimensioning	2	Solution 2		10	
	Description of improvement/modification/re-design	2				
	Functionality of the improvement/strengthening/modification	2				
Subtotal = 15 ÷ 1,5 = TOTAL			+15			
(1 = 1; 2 = 1; 3 = 2; 4 = 3; 5 = 3; 6 = 4; 7 = 5; 8 = 5; 9 = 6; 10 = 7; 11 = 7; 12 = 8; 13 = 9; 14 = 9; 15 = 10)						

a. Freehand drawings			
Freehand drawing method and skills	(See ANNEXURE A on page 24)	10	
NOTE: • No evidence of grid/graph paper used = max. 7 marks, even if drawn excellently • Not drawn in freehand = 0 marks, & some evidence of instruments used = max. 5 marks			
Neatness (2) + correct line types used (2) + line consistency (2) + printing (2) + dimensioning (2)	(Also see ANNEXURE A on page 24)	10	

NOTE:

- **NO freehand drawings, = '0' marks for both 'method & skills' and 'presentation', i.e., = '0' out of '20'!**
- **The mark allocations for final drawing presentation: Neatness (2); Correct line types used (2); Line consistency (2); Printing/writing (2); Dimensioning (2)**

Additional NOTE on 'Freehand drawing method and skills (m & s):

This refers to 'pencil control (hand movement), e.g., straightness of lines, quality of curves etc., the effective 'utilisation of the blocks/grids', and the ability to 'draw to proportion'.

Additional NOTES on the 'Final drawing presentation' (i.e., the 2nd criteria out of '10'):

- 'Correct line types used' refers to 'A-type', 'B-type', 'C-type', 'Medium chain-line' etc.
- 'Line consistency' refers to the consistency of the 'darkness' of the 'specific line-types'.
- If ALL or most of the two freehand drawings, including all or any aspects thereof, were drawn with anything other than PENCIL, e.g., a drawing pen, = '0'(zero) marks for 'correct line types used', and = '0'(zero) marks for 'line consistency'!
- If most of the freehand drawings were drawn in PENCIL, but some or any aspects thereof were drawn with anything other than PENCIL, = - 1 mark penalty on the total out of '10'!
- 'Printing' and 'dimensioning' refers to compliance with the SANS 10111 guidelines.

4. **Select the best solution** that demonstrates an in-depth understanding of the scenario within the context of the design brief.

On a separate page, compare and evaluate the TWO freehand solutions by:

- **Creating a table** with a **minimum of FOUR relevant and descriptive criteria that will facilitate measurable comparisons**. **NOTE: NOT just a 'word', but a self-explanatory criterion!**
- **Creating and applying a simple, self-explanatory rating scale** to score each solution against each criterion (**You must explain the values of your scale!**).
- **Justifying each score** by describing the **positive and/or negative aspects** of each solution against each criterion

Complete the process by writing a **comprehensive summary giving reasons for your selected freehand solution**. The summary **must include whether any late changes were made to the selected freehand solution, or not**. If there were late changes, they must be **clearly described**.

4.	Selecting the best freehand solution (This must be a separate presentation.)		
	An appropriate table created for the selection process		2
	A minimum of FOUR relevant and descriptive criteria that will facilitate measurable comparisons		2
	A simple rating scale created and used to score each solution against each criterion		2
	Each score justified by describing the positive or negative aspects against each criterion		2
	Comprehensive summary with reasons for selected solution (including possible late changes)		2
	TOTAL		10

PHASE 2: PRESENTATION REQUIREMENTS

5. **Present your selected clamp** and the **selected improvement/strengthening/modification** as a **set of working drawings** and a **pictorial drawing** (5.1, 5.2 and 5.3) that meet the following criteria:

- **All the working drawings must be prepared on appropriately sized drawing sheets (A3), set up with correct borders. ONLY the first drawing sheet** (i.e. for 5.1, *‘the Assembly Drawing’*) **must be set up with a complete MECHANICAL TITLE BLOCK ‘and PARTS LIST’**, as presented in the EGD NSC Paper 2 analytical questions (*also see p. 30 of this document for examples*).
- The drawings must provide clear evidence that a **high level of competency has been attained** in the following TWO drawing method:
 - Instrument drawing
 - CAD (computer-aided drawing/design)

NOTE:

- **ONE entire working drawing** (i.e. 5.1 or 5.2) **must be prepared using a pencil and drawing instruments**, and the other using a CAD program.
- The **isometric drawing** (5.3) may be prepared using either a pencil and drawing instruments or a CAD program. **NOTE: If the school’s 3D-Modeling ‘CAD’ Program is to be used to generate the pictorial drawing, the 3D-image does NOT strictly have to be isometric, but just a realistic 3D-image.**
- Schools that **do NOT have CAD facilities** must prepare **ALL** the required working drawings and pictorial drawing (i.e., 5.1, 5.2 and 5.3) **using a pencil and drawing instruments**.
- **ALL aspects of all drawings must comply with the guidelines and conventional representations contained in the SANS 10111.**

5.	Working drawings and a pictorial drawing of your selected clamp, and/or selected change(s)		
	Drawing sheet preparation		
	Appropriately sized drawing sheets		1
	Borders on all drawing sheets of all the working drawings		2
	Complete EGD NSC P2 Q1 compliant MECHANICAL TITLE BLOCK on the drawing sheet of 5.1.		7
	NOTE: Use the 7-mark simplified rubric on page 45 of the CAPS.	TOTAL	10

5.1 **Draw, to a suitable scale and in third-angle orthographic projection, an ASSEMBLY DRAWING of your selected clamp, clearly showing ALL the parts BEFORE any improvements, strengthening or modifications have been affected.**

NOTE:

If your selected clamp has a long bed or frame, use relevant S-breaks or break lines to shorten the length/height of your selected clamp in the assembly drawings, so that a larger scale can be used.

The **ASSEMBLY DRAWING** must show the **following FOUR views**:

- 5.1.1 The **FRONT VIEW** (*the ‘most descriptive’ view of the clamp*)
- 5.1.2 A **second PRIMARY VIEW**
- 5.1.3 **Any other TWO SECONDARY VIEWS**

NOTE: TWO of the views must be sectioned or contain types of sections.

Include the following on the ASSEMBLY DRAWING:

- Scale
- Detailed dimensions
- Title, labels and notes
- Cutting plane(s)
- ALL hatching detail
- Projection symbol

NOTE: The ASSESSMENT CRITERIA for 5.1.1, 5.1.2 and 5.1.3 is for the assessment of the same ASSEMBLY DRAWING, i.e., for ALL the drawings and information on the same drawing sheet!

5.1	ASSEMBLY DRAWING of your clamp, before any changes			
	5.1.1	FRONT VIEW before any changes		
		ALL the parts included and drawn correctly according to the actual clamp	2	
		ALL hatching detail or, if not sectioned, ALL external features	2	
		ALL fasteners drawn correctly in ALL views	2	
		Labels and notes on ALL views	2	
		Projection symbol	1	
		Suitable scale selected for the assembly drawing, and indicated correctly	1	
		TOTAL	10	
	5.1.2	Second PRIMARY VIEW before any changes		
		ALL the components included and drawn correctly according to the actual clamp	2	
		All hatching detail or, if not sectioned, external features	2	
		Dimensions on ALL views	2	
		ALL centre lines included on ALL views	2	
		ALL FOUR views drawn correctly in third-angle orthographic projection	2	
		TOTAL	10	
	5.1.3	Other TWO SECONDARY VIEWS before any changes		
		Appropriate secondary views selected	2	
		ALL the parts included and drawn correctly according to the actual clamp	2	
		All hatching detail or, if not sectioned, external features	2	
		TWO views sectioned or contain types of sections	2	
		Correct cutting planes for the TWO sectional views and/or types of sections	2	
		TOTAL	10	

5.2 **Draw, to a suitable scale and in third-angle orthographic projection, a DETAILED DRAWING of **ONLY** the identified mechanical mechanism, screw mechanism, mechanical locking device, complex main part, or combination of parts of your *selected* clamp, clearly showing the improvement/strengthening/modification.**

The DETAILED DRAWING must show the following THREE views:

5.2.1 The FRONT VIEW (*the 'most descriptive' view*)

5.2.2 **Any other TWO VIEWS**

NOTE: ONE of the views must be sectioned or contain a type of section.

Include the following:

- **Title**, as well as **comprehensive explanatory labels and notes**
- **Relevant welding and/or machining symbols** (if required)
- **Relevant tolerances** (if required)
- **Scale(s)**
- **Detailed dimensioning**
- **Cutting plane(s)**
- **ALL hatching detail**
- **Projection symbol**

c.	CAD drawings			
	Competence displayed in using a CAD program	(See ANNEXURE A on page 24)	10	
	Layout and correctness of the drawings presentation	(See ANNEXURE A on page 24)	10	

NOTE: ANNEXURE A is also included on page 31 of this document!

PHASE 3: PRESENTATION REQUIREMENTS

Create a PAT file/portfolio containing the following in the given sequence:

- A **complete cover page** that includes the school's name and centre number, your full name and surname, grade and class group, your teacher's initials and surname, and a copy of your own isometric drawing for this task.
- A **complete table of contents (index)**
- The **2023 SUMMATIVE ASSESSMENT SHEET** (see page 26 of the 'actual' PAT document, *'or page 33 of this document'*)
- The **completed DECLARATION OF AUTHENTICITY** (see page 27 of the 'actual' PAT document, *'or page 34 of this document'*)

Include the following PHASE 1 and PHASE 2 presentation requirements in the PAT file/portfolio **AFTER** the DECLARATION OF AUTHENTICITY:

1. ALL the **design brief** requirements
2. Evidence of ALL the **resource material used** for the required research
3. The **TWO freehand drawings** of the possible design solutions
4. ALL the evidence of the **selection of the best solution**
5. ALL the required **working drawings** (5.1 and 5.2) and the **isometric drawing** (5.3)
6. The **'ASSESSMENT CRITERIA AND CHECKLIST FOR THE 2023 MECHANICAL PAT'** (see pages 22 and 23), which **must provide clear evidence of your own continuous self-evaluation** and the **meeting of the deadlines** during the development of the PAT.

NOTE: 'Individual' CHECKLISTS cut from the 'combined 'ASSESSMENT CRITERIA AND CHECKLIST FOR THE 2023 MECHANICAL PAT' may also be used!

6.	Continuous self-evaluation and the meeting of deadlines			
	Checklist completed as evidence of continuous self-evaluation	(mark out of 10 ÷ 2)	5	
	The meeting of ALL the submission deadlines	(mark out of 10 ÷ 2)	5	
			TOTAL	10

NOTE:

Include the following **on each page**:

- **Clear numbering** according to the numbers of the presentation requirements
- **Your** (the learner's) **name** and the **date of completion** and **submission**

7.	Presentation of the complete PAT file/portfolio			
	Complete cover page with a copy of the isometric drawing		1	
	Table of contents		1	
	Completed summative assessment sheet and declaration		1	
	Correct sequencing of ALL presentation requirements		1	
	Name and numbering on ALL the presentation requirements		1	
	General impression of file/portfolio, e.g. binding, appearance, etc.	(mark out of 10 ÷ 2)	5	
			TOTAL	10

Assessment criteria and checklist for the 2023 Civil PAT

- The SUMMATIVE ASSESSMENT SHEET on page 26 of the PAT document, *'or page 30 of this document'*, must be used to indicate the final totals out of 10 for each assessment criterion.

NOTE: ALL the Grade 12 PATs must, without exception, be completed and ready for final assessment by Friday 04 August 2023!

ASSESSMENT CRITERIA AND CHECKLIST FOR THE 2023 MECHANICAL PAT							
1-mark level descriptive	0	Requirements not met or presented incorrectly			Checked	Maximum mark	Comments
	1	Requirements has been met and/or presented correctly					
2-mark level descriptive	0	Requirements not met, or less than 30% evidence of knowledge shown (very poor)					
	1	Requirements included and at least 30% evidence of knowledge shown (avg.)					
	2	Presentation shows at least 80% or more evidence of knowledge (very good)					
1. Design Brief							
1.1	1 st paragraph: background and comprehensive description of what is to be designed			2			
1.2	2 nd paragraph: your role and description of the design process you are going to follow			2			
1.3	A list of ALL the specifications of your clamp			2			
1.4	A list of at least THREE constraints of your clamp			2			
1.5	A management plan with target dates for ALL the presentation requirements			2			
				TOTAL	10		
2. Research (This should be restricted to a maximum of THREE A4 or TWO A3 pages per research topic.)							
Relevant and usable research on:	2.1	Materials used for each component of your clamp			2		
	2.2	Design features/function/purpose of each component of your clamp			2		
	2.3	The design, components, mechanisms, etc. of another similar clamp			2		
	Clear evidence that the research was used in your design solutions			2			
	A list of ALL references used (Bibliography)			2			
				TOTAL	10		
3. Freehand drawings of TWO possible design solutions				Final mark for each solution			
Assess each freehand solution as follows:	Third-angle orthographic views of the identified part(s)		2	Solution 1	10		
	Isometric drawing of the identified part(s)		2				
	Correct presentation of ALL the parts and features		1				
	Relative proportion of ALL parts and features to each other		2				
	Labels and explanatory notes		2	Solution 2	10		
	Dimensioning		2				
	Description of improvement/modification/re-design		2				
	Functionality of the improvement/strengthening/modification		2				
Subtotal = 15 ÷ 1,5 = TOTAL			+15				
(1 = 1; 2 = 1; 3 = 2; 4 = 3; 5 = 3; 6 = 4; 7 = 5; 8 = 5; 9 = 6; 10 = 7; 11 = 7; 12 = 8; 13 = 9; 14 = 9; 15 = 10)							
4. Selecting the best freehand solution (This must be a separate presentation.)							
An appropriate table created for the selection process			2				
A minimum of FOUR relevant and descriptive criteria that will facilitate measurable comparisons			2				
A simple rating scale created and used to score each solution against each criterion			2				
Each score justified by describing the positive or negative aspects against each criterion			2				
Comprehensive summary with reasons for selected solution (including possible late changes)			2				
				TOTAL	10		
5. Working drawings and a pictorial drawing of your selected clamp, and/or selected change(s)							
Drawing sheet preparation							
Appropriately sized drawing sheets			1				
Borders on all drawing sheets of all the working drawings			2				
Complete EGD NSC P2 Q1 compliant MECHANICAL TITLE BLOCK on the drawing sheet of 5.1.			7				
NOTE: Use the 7-mark simplified rubric on page 45 of the CAPS.			TOTAL	10			
5.1 ASSEMBLY DRAWING of your clamp, before any changes							
5.1.1	FRONT VIEW before any changes						
	ALL the parts included and drawn correctly according to the actual clamp			2			
	ALL hatching detail or, if not sectioned, ALL external features			2			
	ALL fasteners drawn correctly in ALL views			2			
	Labels and notes on ALL views			2			
	Projection symbol			1			
	Suitable scale selected for the assembly drawing, and indicated correctly			1			
				TOTAL	10		

ASSESSMENT CRITERIA AND CHECKLIST FOR THE 2023 MECHANICAL PAT				
5.1.2	Second PRIMARY VIEW before any changes			
	ALL the components included and drawn correctly according to the actual clamp		2	
	All hatching detail or, if not sectioned, external features		2	
	Dimensions on ALL views		2	
	ALL centre lines included on ALL views		2	
	ALL FOUR views drawn correctly in third-angle orthographic projection		2	
		TOTAL	10	
5.1.3	Other TWO SECONDARY VIEWS before any changes			
	Appropriate secondary views selected		2	
	ALL the parts included and drawn correctly according to the actual clamp		2	
	All hatching detail or, if not sectioned, external features		2	
	TWO views sectioned or contain types of sections		2	
	Correct cutting planes for the TWO sectional views and/or types of sections		2	
		TOTAL	10	
5.2	DETAILED DRAWING of the identified part(s), clearly showing the improvement/strengthening/modification			
	Appropriate view selected as the FRONT VIEW, and is drawn correctly		2	
	TWO other relevant VIEWS selected, and drawn correctly		2	
	Improvement/Strengthening/Modification correlates with selected freehand solution		2	
	Title, as well as comprehensive explanatory labels and notes		2	
	Detailed dimensions		2	
	ONE view sectioned, or contain types of sections, and drawn correctly		2	
	Cutting plane(s)		1	
	ALL hatching detail		2	
	Relevant welding symbols and/or machining symbols and/or tolerances		2	
	Projection symbol		1	
	Suitable scale selected and indicated correctly		1	
	Drawing in third-angle orthographic projection		1	
		Subtotal = 20 ÷ 2 = TOTAL	10	
5.3	Detailed ISOMETRIC DRAWING			
	Suitable scale selected and indicated correctly		1	
	Evidence of ALL auxiliary views and constructions used for the drawing		2	
	Detail and correctness of the isometric drawing		7	
	NOTE: Use the 7-mark simplified rubric on page 45 of the CAPS.			
		TOTAL	10	
6.	Continuous self-evaluation and the meeting of deadlines			
	Checklist completed as evidence of continuous self-evaluation	(mark out of 10 ÷ 2)	5	
	The meeting of ALL the submission deadlines	(mark out of 10 ÷ 2)	5	
		TOTAL	10	
7.	Presentation of the complete PAT file/portfolio			
	Complete cover page with a copy of the isometric drawing		1	
	Table of contents		1	
	Completed summative assessment sheet and declaration		1	
	Correct sequencing of ALL presentation requirements		1	
	Name and numbering on ALL the presentation requirements		1	
	General impression of file/portfolio, e.g. binding, appearance, etc.	(mark out of 10 ÷ 2)	5	
		TOTAL	10	
Assessment of drawing method, drawing skills and presentation				
a.	Freehand drawings			
	Freehand drawing method and skills	(See ANNEXURE A on page 24)		
	NOTE: • No evidence of grid/graph paper used = max. 7 marks, even if drawn excellently			10
	• Not drawn in freehand = 0 marks, & some evidence of instruments used = max. 5 marks			
	Neatness (2) + correct line types used (2) + line consistency (2) + printing (2) + dimensioning (2)	(Also see ANNEXURE A on page 24)		10
b.	Instrument drawings			
	Use of drawing instruments, drawing method and skills	(See ANNEXURE A on page 24)		10
	Neatness (2) + correct line types used (2) + line consistency (2) + printing (2) + dimensioning (2)	(Also see ANNEXURE A on page 24)		10
c.	CAD drawings			
	Competence displayed in using a CAD program	(See ANNEXURE A on page 24)		10
	Layout and correctness of the drawings presentation	(See ANNEXURE A on page 24)		10

REQUIREMENTS for and EXAMPLES of CIVIL TITLE PANES:

5.1.2 Title Panel: To facilitate reference when prints are filed or folded, place the title panel in the bottom right-hand corner of the sheet. The title panel provides the following information:

- project title;
- subject of drawing;
- scale;
- date of drawing;
- project number;
- drawing number and revision letter;
- code references if appropriate;
- name of architect / engineer / planner / surveyor etc.;
- address and telephone number;
- name of project architect, engineer, etc.
- It should also give the names or initials of the persons who:
 - drew / traced / prepared and;
 - checked the drawing.

EXAMPLES of CIVIL TITLE PANELS:

27

SABS 0143
Ed. 1

100 mm

NOTE: Contractors must verify all dimensions and levels on site before commencing work. Architects to be notified immediately of any discrepancies.											
ARCHITECT'S SIGNATURE											
CLIENT'S SIGNATURE											
ANSWER 20 In the space below, draw, in neat freehand, the front view and top view of the SANS 10143 graphical symbol for a WASHTUB.											
<table border="1" style="width: 100%; border-collapse: collapse;"> <thead> <tr> <th>REVISION</th> <th>DATE</th> <th>DESCRIPTION</th> </tr> </thead> <tbody> <tr> <td>2</td> <td>2017-01-09</td> <td>Security lighting</td> </tr> <tr> <td>1</td> <td>2017-01-07</td> <td>New staff parking</td> </tr> </tbody> </table>			REVISION	DATE	DESCRIPTION	2	2017-01-09	Security lighting	1	2017-01-07	New staff parking
REVISION	DATE	DESCRIPTION									
2	2017-01-09	Security lighting									
1	2017-01-07	New staff parking									
3D STUDIO ARCHITECTS 1024 FOREST DRIVE ISIPINGO ☎ 031 555 2792											
PRINTED BY FAST PRINT	DATE OF PRINT 2017-01-28										
DRAWING TITLE SITE PLAN											
PROJECT PROPOSED NEW LOGISTICS CENTRE AND GUARD HOUSE FOR RAGE INDUSTRIES ON PLOT 7392, RIVER HORSE INDUSTRIAL PARK, 28 WILDEBEEST DRIVE, ISIPINGO											
PROJECT NUMBER SSA/FSW-2015	DRAWING NUMBER LF 5-10-BPK/N										
DATE 2017-01-05	DRAWN NM	CHECKED SCALE LUKE 1 : 1500									
REFERENCE CODE V1V1-2017											

NOTE: Contractors must verify all dimensions and levels on site before commencing work. Architects to be notified immediately of any discrepancies.											
ARCHITECT'S SIGNATURE											
CLIENT'S SIGNATURE											
ANSWER 20 In the space below, draw, in neat freehand, the front view and top view of the SANS 10143 graphical symbol for a BATH.											
<table border="1" style="width: 100%; border-collapse: collapse;"> <thead> <tr> <th>REVISION</th> <th>DATE</th> <th>DESCRIPTION</th> </tr> </thead> <tbody> <tr> <td>2</td> <td>2017-07-12</td> <td>Change to new unit</td> </tr> <tr> <td>1</td> <td>2017-06-30</td> <td>Move substation</td> </tr> </tbody> </table>			REVISION	DATE	DESCRIPTION	2	2017-07-12	Change to new unit	1	2017-06-30	Move substation
REVISION	DATE	DESCRIPTION									
2	2017-07-12	Change to new unit									
1	2017-06-30	Move substation									
M+C ARCHITECTS 95# MAIN ROAD UPINGTON ☎ 082 555 1234											
PRINTED BY GREENSIDE PRINTERS	DATE OF PRINT 2017-08-01										
DRAWING TITLE SITE PLAN											
PROJECT PROPOSED NEW UNIT AND PARKING FOR SUB 4 OF LOT 581, GREENSIDE INDUSTRIAL PARK, 177 WEST PARK DRIVE, UPINGTON											
PROJECT NUMBER JUMC/VL-2017	DRAWING NUMBER SU 6-11-GIPU/8										
DATE 2017-05-05	DRAWN ENID	CHECKED SCALE KARN 1 : 1000									
REFERENCE CODE P1Q1-2017											

EXAMPLES of LABELS and NOTES:

LABELS:

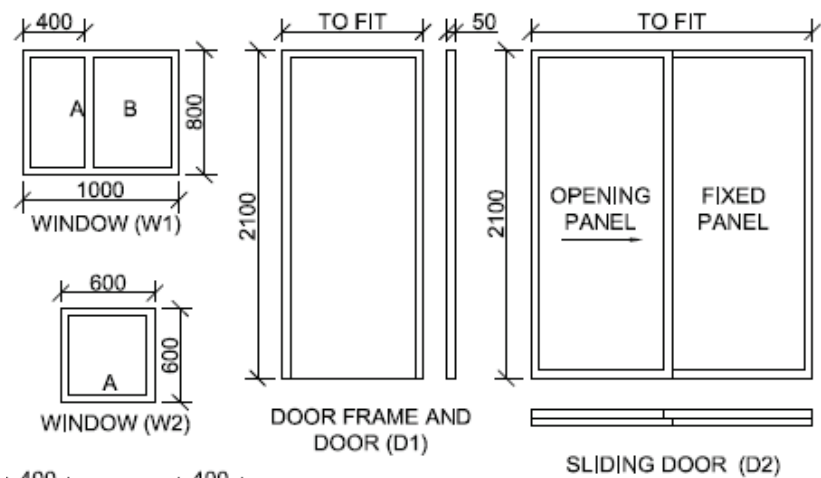
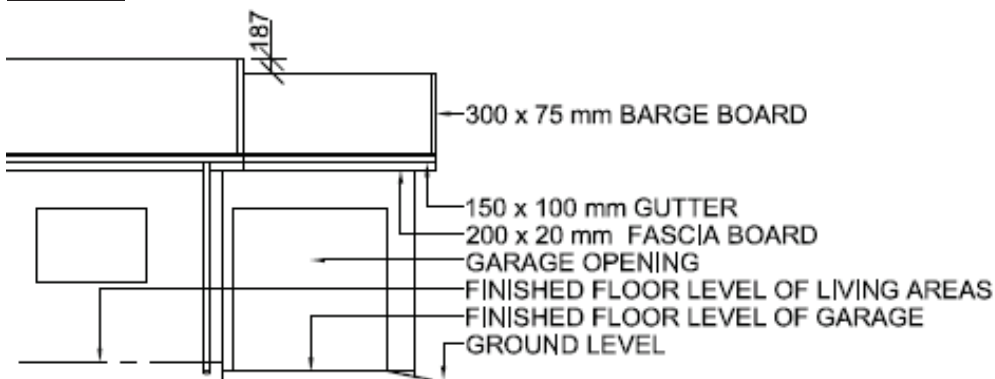

NOTES:

ROOF NOTES:

ROOF PITCH 20°

115 x 38 mm ROOF TRUSSES ON
115 x 38 mm WALL PLATES

ROOF OVERHANG 300 mm TO END OF
ROOF TRUSSES

ROOF COVER 40 mm IBR SHEETING ON
75 x 50 mm PURLINS @ 1000 mm c/c

220 x 20 mm FASCIA BOARD ON ALL
SIDES AND 300 x 75 mm BARGE BOARD
ON GABLED ENDS

100 x 150 mm GUTTERS ON ALL SIDES

9 mm CEILING BOARDS ON 38 x 38 mm
BRANDING STRIPS @ 300 mm c/c

WINDOW NOTES:

- A = OPENING SIDE
- B = FIXED PANEL
- ALL FRAMES 40 mm
- 150 x 20 mm FIBRE CEMENT SILL UNDER ALL WINDOWS

NOTE: Rather use ROOF NOTES for the DETAILED SECTION, instead of dimensions directly to the ROOF itself!

EXAMPLES of MECHANICAL TITLE BLOCKS:

PARTS LIST				DRAWING PROGRAM; AUTOCAD 2017	
PART	QUANTITY	MATERIAL	ALL UNSPECIFIED RADII ARE R2.		SCALE 1 : 1
1	FIXED JAW AND HANDLE	1	CHROME VANADIUM CASTING	APPROVED: STEYN	DATE: 2017-02-28
2	ADJUSTABLE JAW	1	TOOL STEEL	CHECKED: JOHN	DATE: 2017-02-10
3	WORM SCREW	1	EN 19	DRAWN: WERNER	DATE: 2017-01-08
4	WORM SHAFT	1	TOOL STEEL	TITLE SHIFTING SPANNER	
HEAT TREATMENT ON ALL JAWS		HARDENING			
METHOD OF MACHINING		MILLING	✓ ⊥		





PARTS LIST			13/11/2016		PEDRO		INSERT GLAND		1		TITLE		UNLESS OTHERWISE SPECIFIED, TOLERANCES ON DIMENSIONS ARE ± 0,15.		MILLING	
PART	QUANTITY	MATERIAL	DATE	CHANGED BY	REVISION DESCRIPTION	No	SCALE 1 : 2		HEAT TREATMENT: NONE		TWO-WAY VALVE		ALL DIMENSIONS ARE IN MILLIMETRES.		DRAWN: CARL DATE: 11/11/2016	
1	BASE	1	BRASS	FILE NAME: VA103/2016		DRAWING SET NO. 3 OF 4		ALL VALVE MANUFACTURING		MAIN STREET GEORGE 6520 www.v4a.co.za		ALL UNSPECIFIED RADII ARE R4.		CHECKED: SUE DATE: 15/11/2016		
2	BUSH	1	BRASS	DRAWING PROGRAM: AUTOCAD 2016		APPROVED: TINI DATE: 16/01/2017		DRAWING PROGRAM: AUTOCAD 2016		APPROVED: TINI DATE: 16/01/2017		DRAWING PROGRAM: AUTOCAD 2016		APPROVED: TINI DATE: 16/01/2017		
3	GLAND	1	NYLON	DRAWING PROGRAM: AUTOCAD 2016		APPROVED: TINI DATE: 16/01/2017		DRAWING PROGRAM: AUTOCAD 2016		APPROVED: TINI DATE: 16/01/2017		DRAWING PROGRAM: AUTOCAD 2016		APPROVED: TINI DATE: 16/01/2017		
4	M56 NUT	1	BRASS	DRAWING PROGRAM: AUTOCAD 2016		APPROVED: TINI DATE: 16/01/2017		DRAWING PROGRAM: AUTOCAD 2016		APPROVED: TINI DATE: 16/01/2017		DRAWING PROGRAM: AUTOCAD 2016		APPROVED: TINI DATE: 16/01/2017		
5	SHAFT	1	EN 19	DRAWING PROGRAM: AUTOCAD 2016		APPROVED: TINI DATE: 16/01/2017		DRAWING PROGRAM: AUTOCAD 2016		APPROVED: TINI DATE: 16/01/2017		DRAWING PROGRAM: AUTOCAD 2016		APPROVED: TINI DATE: 16/01/2017		



22/04/2015	ANDREW	INSERT CIRCLIP	3	DRAWING SET: 4 OF 5	DRAWN: PETER	07/03/2015
16/04/2015	ANDREW	INSERT GRUB SCREW	2	DRAWING PROGRAM: AutoCAD 2014	CHECKED: JOHN	13/03/2015
16/03/2015	ANDREW	CHANGE BUSH	1	DRAWING No. PUNCH/34/2015	APPROVED: ILSE	29/05/2015
DATE	CHANGED BY	REVISION DESCRIPTION	No.	FILE NAME: punch3.dwg	MATERIAL: CAST IRON	
PUNCH				UNLESS OTHERWISE SPECIFIED, ALL DIMENSIONS ARE IN MILLIMETRES WITH A TOLERANCE OF 0,25.		HEAT TREATMENT: TEMPER
WEST COAST ENGINEERS (SA) (Pty) Ltd 15 MAIN ROAD VELDDRIFT 7365 www.wce.co.za ☎ 022 959 5432				✓ FOR SURFACE FINISHES		SCALE 2 : 1
						QUANTITY: 200



2011-08-12	N BOOTH	LENGTHEN INSPECTION PLUG	3			
2011-08-09	N BOOTH	SHOW MACHINED SURFACES	2			
2011-08-05	N BOOTH	REMOVE WASHER	1			
DATE	REVISED BY	REVISION DESCRIPTION	No			
DRAWING No. 60305		MATERIAL: BRONZE				
FILE NAME: SCV 15-10		HEAT TREATMENT: NORMALISE		ALL DIMENSIONS ARE IN MILLIMETRES.		
UNLESS OTHERWISE SPECIFIED, TOLERANCES ON DIMENSIONS ARE ± 0,25.		DRAWING PROGRAMME: AUTOCAD 2011		DRAWN BY: S SHABALALA		2011-07-22
		ALL UNSPECIFIED RADII ARE R2.		CHECKED BY: S PIENAAR		2011-07-24
 MECHTECH ENGINEERING		17 LONG STREET NEW PARK KIMBERLEY 8300 www.mtech.co.za ☎ 053 645 7820		APPROVED BY: A MOKOENA		2011-08-03
				SCALE: 1 : 2		
TITLE				SWING CHECK VALVE		0,8/ ✓



9. SIMPLIFIED RUBRIC FOR ALLOCATION AND VERIFICATION OF MARKS

NOTE:

- **The final mark out of 10 of each assessment criterion, i.e., the overall level of achievement according to the presentation requirement, must be verified according to this rubric.**
- This rubric must also be used to allocate marks for all aspects of the assessment criteria which require a mark out of 10.

VERIFICATION AND MARK ALLOCATION			
DESCRIPTION FOR MARK	GENERAL INDICATOR	± %	MARK
ALL/MORE than ALL the REQUIREMENTS are met. - PERFECT -	Error-free	100%	10
ALL (ALMOST ALL) the REQUIREMENTS are met. - OUTSTANDING -	Very few errors	90% +	9
ALMOST ALL (MOST OF) the REQUIREMENTS are met. - VERY GOOD -	Few errors	80% +	8
The REQUIREMENTS are met SUBSTANTIALLY . - GOOD -	Some errors	70% +	7
The REQUIREMENTS are met ADEQUATELY . - SATISFACTORY -		60% +	6
The REQUIREMENTS are met MODERATELY . - ACCEPTABLE -	Many errors	50% +	5
ONLY SOME of the REQUIREMENTS are met. - UNACCEPTABLE -		40% +	4
VERY FEW of the REQUIREMENTS are met. - NOT ACHIEVED -	Mostly wrong	30% + Only a few correct features	3
The REQUIREMENTS are NOT met. - VERY POOR -	Completely wrong	29% and LESS	2
		Something done incorrectly/ poorly	1
NOT DONE	No work handed in!	Nothing to mark!	0

10. PAT 2023: SUMMATIVE ASSESSMENT SHEET

PAT 2023 SUMMATIVE ASSESSMENT SHEET	
NAME OF SCHOOL:	DISTRICT:
NAME OF LEARNER:	(NAME AND SURNAME)
NAME OF TEACHER:	(NAME AND SURNAME)
NAME OF MODERATOR:	(NAME AND SURNAME) DATE:

PART A: Design Process		PART B: Working and pictorial drawings		Drawing competency and skill			
CRITERIA	MARK	CRITERIA	MARK	CRITERIA	MARK		
1	A design brief demonstrating a clear understanding of the scenario and the specifications, constraints and a management plan	All drawing sheets are appropriately set up with a border and an appropriate title block/panel.		Freehand drawing: <small>ANNEXURE A</small>	METHOD	The drawings display correct freehand drawing method and skills and the method used to ensure proportion and size.	
2	Evidence of relevant and usable research with the inclusion of a bibliography	Orthographic drawings <small>Assess each view's accuracy and correctness according to the selected solution/device, the stipulated requirements and drawing principals</small>	5.1.1		View 1 PAT 1: Plan PAT 2: Front view		The final drawing presentation is neat and there is consistency of line work/line quality, printing and dimensioning.
3	TWO detailed freehand drawings of possible solutions 1st Solution 2nd Solution		5.1.2	View 2 PAT 1: Elevations (x2) PAT 2: 2nd main view	Instrument drawing: <small>ANNEXURE A</small>	METHOD	The drawings display the correct use of drawing instruments, drawing method and skills.
			5.1.3	View 3 PAT 1: Detailed section(s) PAT 2: Secondary views (x2)			The final drawing presentation is neat and there is consistency of line work/line quality, printing and dimensioning.
4	Selecting the best solution which demonstrates a clear understanding of the design brief		5.2	PAT 1: Site plan PAT 2: Detailed drawing	CAD drawing: <small>ANNEXURE A</small>	METHOD	The level of competence is displayed in using a CAD program.
6	Clear evidence of evaluation and the meeting of deadlines of all the requirements	Pictorial Drawing 5.3	The correct drawing method and presentation of the pictorial drawing. PAT 1: Perspective PAT 2: Isometric			The layout of the final drawing is correct and the line work, printing and dimensioning is compliant and consistent.	
7	The presentation of the complete PAT portfolio				NO CAD drawings / 40		
SUBTOTAL / 70		SUBTOTAL / 60		With CAD drawings / 60			
CALCULATION X 0.36		CALCULATION X 0.84		CALCULATION without CAD X 0.63			
CALCULATION with CAD X 0.42		Teacher's TOTAL		Teacher's TOTAL			
TOTAL: A / 25		TOTAL: B / 50		TOTAL: C / 25			
Moderated TOTAL		Moderated TOTAL		Moderated TOTAL			
TOTAL: A / 25		TOTAL: B / 50		TOTAL: C / 25			
TEACHER'S TOTAL:		A + B + C = / 100		TEACHER: Initial			
MODERATED TOTAL:		A + B + C = / 100		MODERATOR: Initial			

11. DECLARATION OF AUTHENTICITY

DECLARATION OF AUTHENTICITY

To be submitted with each learner's practical assessment task portfolio

NAME OF THE SCHOOL:

NAME OF LEARNER:
(SURNAME AND INITIALS)

I hereby declare that all the contents of the practical assessment task (PAT) submitted by myself for assessment is my own original work and has not been plagiarised, copied from someone else or previously submitted for assessment.

SIGNATURE OF LEARNER



DATE / / 2023
(DD/MM/YYYY)

NAME OF TEACHER:
(SURNAME AND INITIALS)

As far as I know, the above declaration by the candidate is true and I accept that the PAT submitted is his/her own work.

SIGNATURE OF TEACHER

DATE / / 2023
(DD/MM/YYYY)



SCHOOL STAMP